

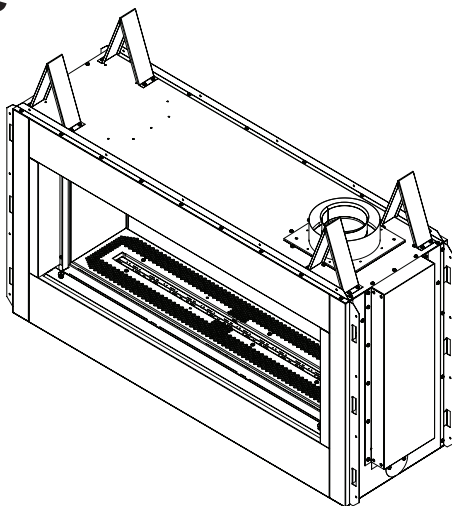

## DIRECT VENT FIREPLACE OWNER'S OPERATION AND INSTALLATION MANUAL



### MODELS (V)LDV43NE AND (V)LDV43PE

**⚠ WARNING:** If the information in this manual is not followed exactly, a fire or explosion may result causing property damage, personal injury or loss of life.

- Do not store or use gasoline or other flammable vapors and liquids in the vicinity of this or any other appliance.
- **WHAT TO DO IF YOU SMELL GAS**
  - Do not try to light any appliance.
  - Do not touch any electrical switch; do not use any phone in your building.
  - Immediately call your gas supplier from a neighbor's phone. Follow the gas supplier's instructions.
  - If you cannot reach your gas supplier, call the fire department.
- Installation and service must be performed by a qualified installer, service agency or the gas supplier.

**INSTALLER:** Leave this manual with the appliance  
**CONSUMER:** Retain this manual for future reference.

## TABLE OF CONTENTS

Safety .....	2	Inspecting Burners.....	28
Local Codes.....	4	Cleaning and Maintenance.....	28
Product Identification.....	5	Gas Control Module System.....	30
Product Features .....	5	Troubleshooting .....	34
Requirements for the Commonwealth of Massachusetts.....	6	Wiring Diagram.....	37
Pre-installation.....	7	Parts .....	38
Location of Termination Cap.....	10	Accessories .....	41
Venting Installation .....	11	Specifications .....	42
Fireplace Installation.....	19	Replacement Parts.....	42
Operation.....	26	Technical Service.....	42
		Service Hints.....	42
		Warranty.....	Back Cover

## SAFETY

**⚠ WARNING:** Improper installation, adjustment, alteration, service or maintenance can cause injury or property damage. Refer to this manual for correct installation and operational procedures. For assistance or additional information consult a qualified installer, service agency or the gas supplier.

This appliance is only for use with the type of gas indicated on the rating plate. This appliance is not convertible for use with other gases, unless a certified kit is used.

**State of Massachusetts:** The installation must be made by a licensed plumber or gas fitter in the Commonwealth of Massachusetts.

**⚠ WARNING:** This product contains and/or generates chemicals known to the State of California to cause cancer or birth defects or other reproductive harm.

**IMPORTANT:** Read this owner's manual carefully and completely before trying to assemble, operate or service this fireplace. Improper use of this fireplace can cause serious injury or death from burns, fire, explosion, electrical shock and carbon monoxide poisoning.

**⚠ DANGER:** Carbon monoxide poisoning may lead to death!

## ⚠ WARNING



**HOT GLASS WILL  
CAUSE BURNS.**

**DO NOT TOUCH GLASS  
UNTIL COOLED.**

**NEVER ALLOW CHILDREN  
TO TOUCH GLASS.**

## SAFETY

### Continued

This vented gas fireplace is a sealed combustion gas fireplace designed for residential applications. This fireplace must be installed with FMI PRODUCTS, LLC vent pipe components and terminations.

This fireplace complies with the *National Safety Standards* and is listed and tested by *PFS Corporation to ANSI Z21.88/CSA 2.33* standard as vented gas fireplace heaters.

This fireplace must be installed by a qualified (certified or licensed) service person. It brings in fresh air for combustion through the outer pipe and combustion gases are exhausted through the inner pipe. If the glass door assembly and venting pipe are not properly seated, connected and sealed, carbon monoxide leakage (spillage) can occur.

**Carbon Monoxide Poisoning:** Early signs of carbon monoxide poisoning resemble the flu, with headaches, dizziness or nausea. If you have these signs, the fireplace may not be working properly. **Get fresh air at once!** Have fireplace serviced. Some people are more affected by carbon monoxide than others. These include pregnant women, people with heart or lung disease or anemia, those under the influence of alcohol and those at high altitudes.

**Natural and Propane/LP Gas:** Natural and propane/LP gas are odorless. An odor-making agent is added to the gas. The odor helps you detect a gas leak. However, the odor added to the gas can fade. Gas may be present even though no odor exists.

Make certain you read and understand all warnings. Keep this manual for reference. It is your guide to safe and proper operation of this fireplace.

 **WARNING: Any change to this fireplace or its controls can be dangerous. Do not modify this fireplace under any circumstances. Any parts removed for servicing must be replaced prior to operating fireplace.**

 **WARNING: Do not use a blower insert, heat exchanger insert or other accessory not approved for use with this fireplace.**

 **WARNING: This appliance is only for use with the type of gas indicated on the rating plate. This appliance is not convertible for use with other gases unless a certified kit is used.**

 **WARNING: Do not allow fans to blow directly into the fireplace. Avoid any drafts that alter burner flame patterns.**

**Due to high temperatures, the appliance should be located out of traffic and away from furniture and draperies.**

**Do not place clothing or other flammable material on or near the appliance. Never place any objects on the appliance.**

**Do not use this fireplace to cook food or burn paper or other flammable material.**

**This fireplace reaches high temperatures. Keep children and adults away from hot surface to avoid burns or clothing ignition. Fireplace will remain hot for a time after shutdown. Allow surface to cool before touching.**

**Carefully supervise young children when they are in the room with fireplace.**

**Keep the area around your fireplace clear of combustible materials, gasoline and other flammable vapor or liquids. Do not run fireplace where these are used or stored.**

# SAFETY

## Continued

1. For propane/LP fireplace, do not place propane/LP supply tank(s) inside any structure. Locate propane/LP supply tank(s) outdoors. To prevent performance problems, do not use propane/LP fuel tank of less than 100 lb. capacity.
2. If you smell gas
  - shut off gas supply
  - do not try to light any appliance
  - do not touch any electrical switch; do not use any phone in your building
  - immediately call your gas supplier from a neighbor's phone. Follow the gas supplier's instructions
  - if you cannot reach your gas supplier, call the fire department.
3. Never install the fireplace
  - in a recreational vehicle
  - in windy or drafty areas where curtains or other combustible (flammable) objects can make contact with the fireplace front
  - in high traffic areas
4. Turn fireplace off and let cool before servicing, installing or repairing. Only a qualified service person should install, service or repair this fireplace. Have fireplace inspected annually by a qualified service person.
5. You must keep control compartments, burners and circulating air passages clean. More frequent cleaning may be needed due to excessive lint and dust from carpeting, bedding material, etc. Turn off the gas valve and pilot light before cleaning fireplace.
6. Have venting system inspected annually by a qualified service person. If needed, have venting system cleaned or repaired. See *Cleaning and Maintenance*, page 28.
7. Do not use any solid fuels (wood, coal, paper, cardboard, etc.) in this fireplace. Use only the gas type indicated on fireplace nameplate.
8. This appliance, when installed, must be electrically grounded in accordance with local codes or, in the absence of local codes, with the *National Electrical Code, ANSI/NFPA 70* or *Canadian Electrical Code, CSA C22.1*.
9. Do not use fireplace if any part has been exposed to or under water. Immediately call a qualified service person to arrange for replacement of the unit.
10. Do not operate fireplace with glass door removed, cracked or broken.
11. Provide adequate clearances around air openings.

## LOCAL CODES

Install and use fireplace with care. Follow all local codes. In the absence of local codes, use the current *National Fuel Gas Code ANSI Z223.1/NFPA 54\** (USA) or the current *CSA-B149.1 Installation Code* (Canada).

\*Available from:

American National Standards Institute, Inc.  
1430 Broadway  
New York, NY 10018  
National Fire Protection Association, Inc.  
Batterymarch Park  
Quincy, MA 02269

## PRODUCT IDENTIFICATION

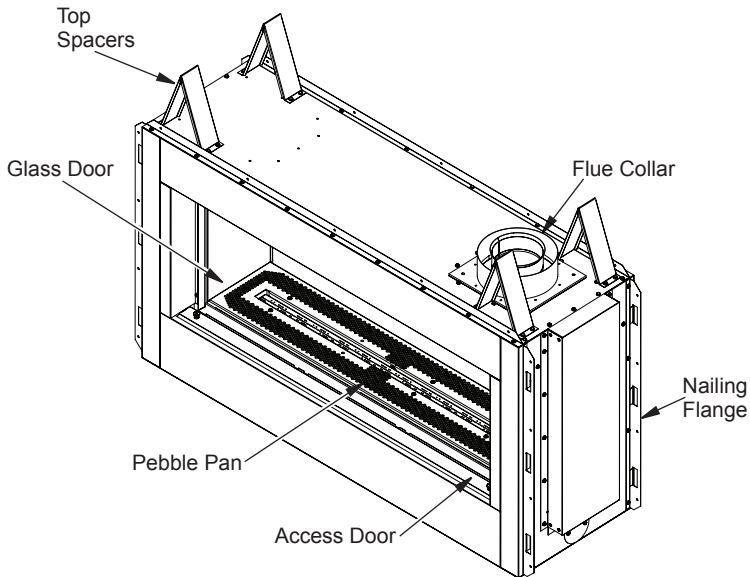

*Figure 1 - Direct Vent Linear Fireplace*

## PRODUCT FEATURES

These are a few facts that can help you understand and enjoy your direct vent fireplace:

- The venting system may be routed to the outside of your home in several ways. It may vent through the roof (vertical) or it may vent to an outside/exterior wall (horizontal). The vent pipe installation is very important to allow for proper operation. You must follow the venting instructions very carefully for either vertical or horizontal applications.
- This fireplace may be installed in any room of your house provided all local codes and these installation instructions are followed.
- Each time you turn on your fireplace, you may notice some amount of condensation on the inside of the fireplace glass. This is normal and will disappear after 10-20 minutes of operation.
- Your direct vent gas fireplace system (fireplace and venting) is a balanced and sealed gas operating unit. It requires approximately 10-20 minutes of operating time before the flame pattern stabilizes.

# REQUIREMENTS FOR THE COMMONWEALTH OF MASSACHUSETTS

For all side wall horizontally vented gas fueled equipment installed in every dwelling, building or structure used in whole or in part for residential purposes, including those owned or operated by the Commonwealth and where the side wall exhaust vent termination is less than seven (7) feet above finished grade in the area of the venting, including but not limited to decks and porches, the following requirements shall be satisfied:

## INSTALLATION OF CARBON MONOXIDE DETECTORS

At the time of installation of the side wall horizontally vented gas fueled equipment, the installing plumber or gasfitter shall observe that a hard wired carbon monoxide detector with an alarm and battery backup is installed on the floor level where the gas equipment is to be installed. In addition, the installing plumber or gasfitter shall observe that a battery operated or hard wired carbon monoxide detector with an alarm is installed on each additional level of the dwelling, building or structure served by the side wall horizontal vented gas fueled equipment. It shall be the responsibility of the property owner to secure the services of qualified licensed professionals for the installation of hard wired carbon monoxide detectors.

In the event that the side wall horizontally vented gas fueled equipment is installed in a crawl space or an attic, the hard wired carbon monoxide detector with alarm and battery back-up may be installed on the next adjacent floor level.

In the event that the requirements of this subdivision can not be met at the time of completion of installation, the owner shall have a period of thirty (30) days to comply with the above requirements; provided, however, that during said thirty (30) day period, a battery operated carbon monoxide detector with an alarm shall be installed.

### Approved Carbon Monoxide Detectors

Each carbon monoxide detector as required in accordance with the above provisions shall comply with NFPA 720 and be ANSI/UL 2034 listed and IAS certified.

## SIGNAGE

A metal or plastic identification plate shall be permanently mounted to the exterior of the building at a minimum height of eight (8) feet above grade directly in line with the exhaust vent terminal for the horizontally vented gas fueled heating appliance or equipment. The sign shall read, in print size no less than 1/2" in size, "GAS VENT DIRECTLY BELOW. KEEP CLEAR OF ALL OBSTRUCTIONS".

## INSPECTION

The state or local gas inspector of the side wall horizontally vented gas fueled equipment shall not approve the installation unless, upon inspection, the inspector observes carbon monoxide detectors and signage installed in accordance with the provisions of 248 CMR 5.08(2)(a) 1 through 4.

EXEMPTIONS: The following equipment is exempt from 248 CMR 5.08(2)(a) 1 through 4:

- The equipment listed in Chapter 10 entitled "Equipment Not Required To Be Vented" in the most current edition of NFPA 54 as adopted by the Board; and
- Product Approved side wall horizontally vented gas fueled equipment installed in a room or structure separate from the dwelling, building or structure used in whole or in part for residential purposes.

## MANUFACTURER REQUIREMENTS Gas Equipment Venting System Provided

When the manufacturer of Product Approved side wall horizontally vented gas equipment provides a venting system design or venting system components with the equipment, the instructions provided by the manufacturer for installation of the equipment and the venting system shall include:

- Detailed instructions for the installation of the venting system design or the venting system components; and
- A complete parts list for the venting system design or venting system.

## Gas Equipment Venting System Not Provided

When the manufacturer of a Product Approved side wall horizontally vented gas fueled equipment does not provide the parts for venting the flue gases, but identifies "special venting systems", the following requirements shall be satisfied by the manufacturer:

- The referenced "special venting system" instructions shall be included with the appliance or equipment installation instructions; and
- The "special venting systems" shall be Product Approved by the Board, and the instructions for that system shall include a parts list and detailed installation instructions.

A copy of all installation instructions for all Product Approved side wall horizontally vented gas fueled equipment, all venting instructions, all parts lists for venting instructions, and/or all venting design instructions shall remain with the appliance or equipment at the completion of the installation.

# PRE-INSTALLATION

## LOCATION AND SPACE REQUIREMENTS

Determine the safest and most efficient location for your direct vent fireplace. Make sure that rafters and wall studs are not in the way of the venting system. Choose a location where the heat output is not affected by drafts, air conditioning ducts, windows or doors. Be aware of all restrictions and precautions before deciding the exact location for your fireplace and termination cap.

When deciding the location of your fireplace, follow these rules:

- Do not connect this fireplace venting to a chimney flue serving a separate solid-fuel burning fireplace or appliance.
- Due to high temperatures, do not locate this fireplace in high traffic areas, windy or drafty areas or near furniture or draperies.
- Proper clearances must be maintained.
- If your fireplace is to be installed directly on carpeting, vinyl tile or any combustible material other than wood, it must be installed on a metal or wood panel extending the full width and depth of the fireplace (see Figure 6).
- If standoff spacers are attached to your fireplace, these spacers can be placed directly against wall or framing material. See framing details, page 8.
- When locating termination cap, it is important to observe the minimum clearances shown in Figure 7, page 10.
- Do not recess termination cap into a wall or siding.
- You may paint the termination cap with 450° F (232° C) heat-resistant paint to coordinate with the exterior finish.
- There must not be any obstruction such as bushes, garden sheds, fences, decks or utility buildings within 24" from the front of the termination cap and the front of outside air vent.
- Do not locate termination cap and outside air vent where excessive snow or ice build up may occur. Be sure to clear vent termination area after snow falls to prevent accidental blockage of venting system. When using snow blowers, do not direct snow towards vent termination area.

## CLEARANCES

Minimum clearances to combustibles for the fireplace are as follows:

*Back and sides	1"
Perpendicular walls	8"
Floor (From bottom of Fireplace)	0"
Ceiling (From bottom of Fireplace)	63"
Top of Enclosure	
(From bottom of Fireplace)	63"
Top of Standoffs	0"
Vent	1"

(See venting instructions for specific venting clearances.)

\* For back and sides of fireplace, do not pack with insulation or other materials.

**NOTICE: This fireplace is intended for use as supplemental heat. Use this fireplace along with your primary heating system. Do not install this fireplace as your primary heat source. If you have a central heating system, you may run system's circulating blower while using fireplace. This will help circulate the heat throughout the house.**

## FRAMING AND FINISHING

Figure 2, page 8 shows typical framing of this fireplace. Figure 3, page 8 shows framing for see-thru installation. All minimum clearances must be met. Vent pipe needs to maintain 1" clearance. Steel framing may be necessary or wood studs may be notched. Concrete board is provided for facing around the fireplace as shown in Figure 4, page 8.

If you are using a separate combustible mantel piece, refer to Figure 5 page 8 for proper installation height. You can install noncombustible mantels at any height above the fireplace.

*Note: Noncombustible mantels may discolor!*

# PRE-INSTALLATION

Continued

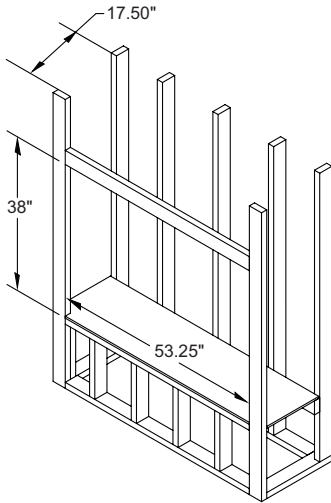

Figure 2 - Framing Clearances for One Sided Application

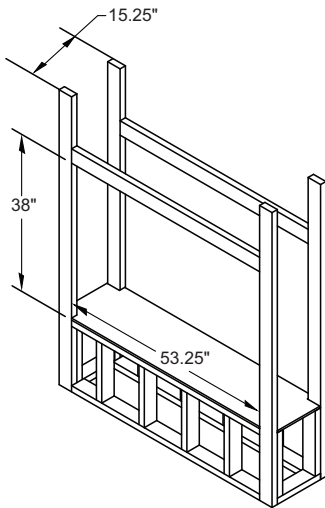

Figure 3 - Framing Clearances for See-Thru Application

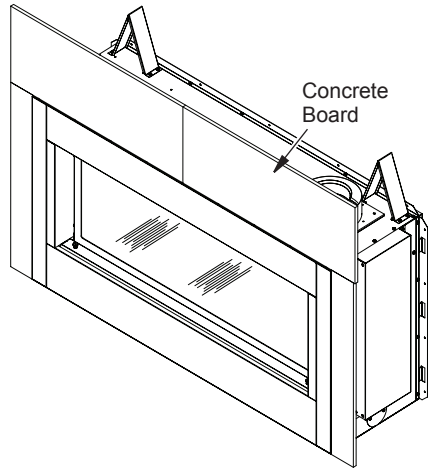

Figure 4 - Installing Concrete Board

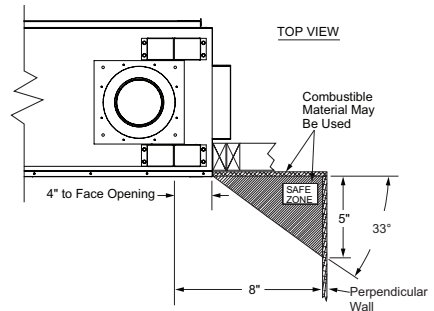
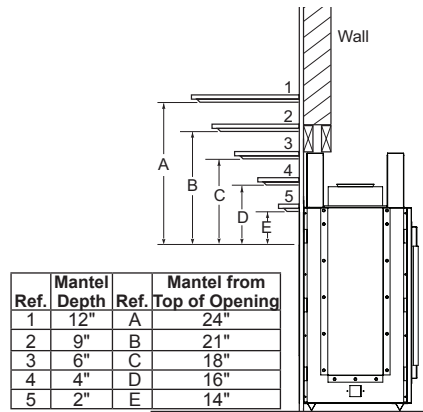

Figure 5 - Clearances for Combustible Mantels



# PRE-INSTALLATION

Continued

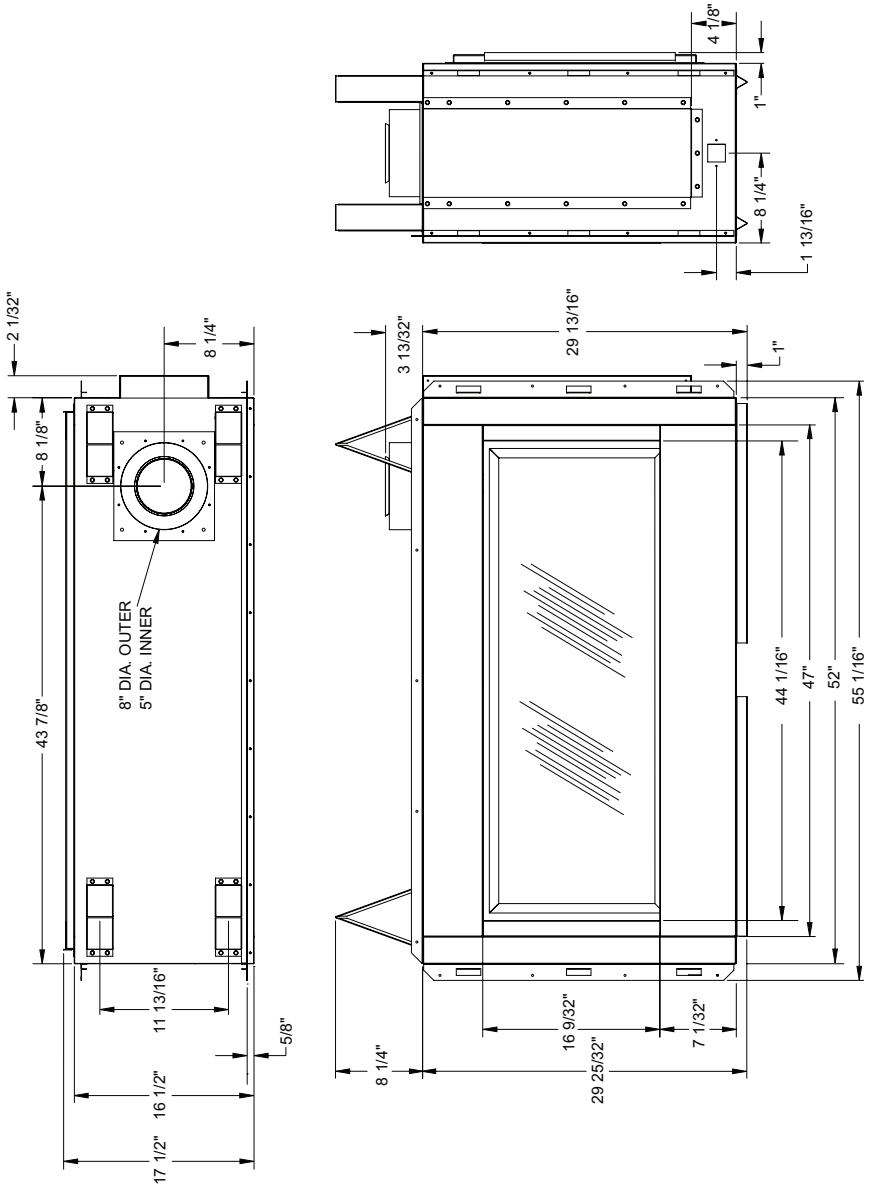
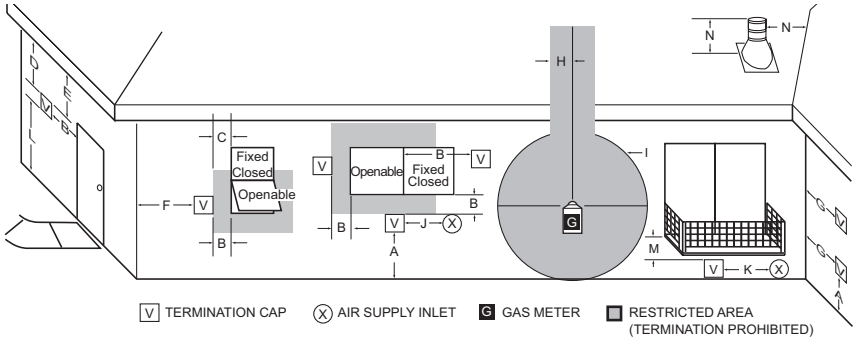

Figure 6 - (V)LDV43 Series Dimensions

# LOCATION OF TERMINATION CAP



- A = clearance above grade, veranda, porch, deck, or balcony [\*12" (30.5 cm) minimum]
- B = clearance to window or door that may be opened [6" (15 cm) min. for 10,000 Btu or less; 9" (23 cm) in US if between 10,000 and 50,000, 12" (30 cm) in Canada if between 10,000 and 100,000; 12" (30 cm) in US if greater than 50,000, 36" (91 cm) in Canada if greater than 100,000]
- C = clearance to permanently closed window [minimum 12" (30.5 cm) recommended to prevent condensation on window]
- D = vertical clearance to ventilated soffit located above the terminal within a horizontal distance of 24" (61 cm) from the center-line of the terminal [18" (45.7 cm) minimum]
- E = clearance to unventilated soffit [12" (30.5 cm) minimum]
- F = clearance to outside corner (see below)
- G = clearance to inside corner (see below)
- H = \*not to be installed above a meter/regulator assembly within 36" (91.4 cm) horizontally from the center line of the regulator
- I = clearance to service regulator vent outlet [\*72" (182.9 cm) minimum]
- J = clearance to non-mechanical air supply inlet to building or the combustion air inlet to any other fireplace [6" (15 cm) min. for 10,000 Btu or less; 9" (23 cm) in US if between 10,000 and 50,000, 12" (30 cm) in Canada if between 10,000 and 100,000; 12" (30 cm) in US if greater than 50,000, 36" (91 cm) in Canada if greater than 100,000]
- K = clearance to a mechanical air supply inlet [\*In Canada, 6 ft. (1.83m) minimum; In US 3 ft. (91 cm) above if within 10 ft. (3 m) horizontally]
- L = † clearance above paved side-walk or a paved driveway located on public property [\*84" (213.3 cm) minimum]
- M = clearance under veranda, porch, deck [\*12" (30.5 cm) minimum ‡]
- N = clearance above a roof shall extend a minimum of 24" (61 cm) above the highest point when it passes through the roof surface and any other obstruction within a horizontal distance of 18" (45.7 cm)

† vent shall not terminate directly above a side-walk or paved driveway which is located between two single family dwellings and serves both dwellings\*

‡ only permitted if veranda, porch, deck or balcony is fully open on a minimum of 2 sides beneath the floor\*

\* as specified in CAN/CSA B149 (.1 or .2) Installation Codes (1991) for Canada and U.S.A.

Note: Local codes or regulations may require different clearances

## Termination Clearances for Buildings with Combustible and Noncombustible Exteriors

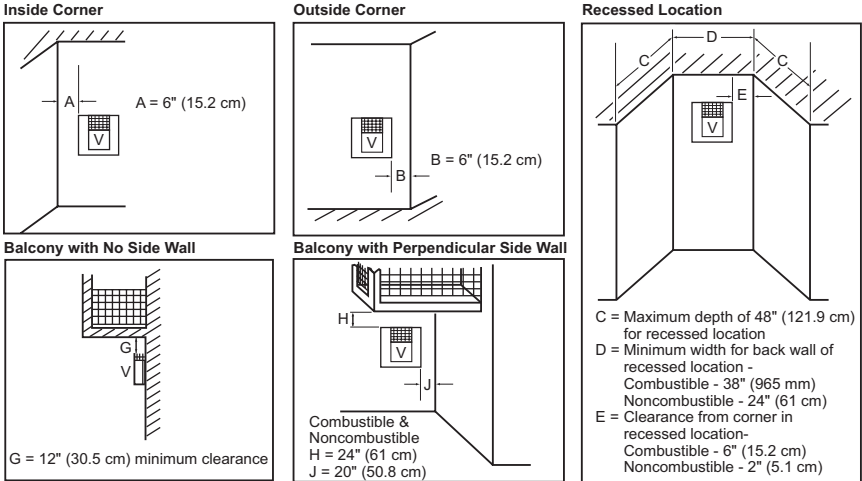

Figure 7 - Minimum Clearances for Termination Cap

## VENTING INSTALLATION

**NOTICE: Read these instructions completely before attempting installation.**

These models are tested and approved for use with FMI PRODUCTS, LLC (direct vent) pipe components and terminations.

The venting system must terminate on the outside of the structure and can not be attached to a chimney or flue system serving a separate solid fuel or gas burning appliance. A direct vent appliance must have its own venting system. DO NOT common vent this appliance.

These models are approved to be vented either horizontally through an outside wall or vertically through a roof or chase enclosure using the following guidelines:

- When venting system terminates horizontally on an outside wall, you may install a standoff if the termination cap is to be installed directly on a combustible finish such as vinyl, wood, stucco, etc.
- Never run the vent downward as this may cause excessive temperatures which could cause a fire.
- Vent pipe air space clearances to combustibles are 1" on all sides except on the horizontal sections, which requires 2" clearance from the top of the pipe. Where the termination cap penetrates a combustible wall, 1" air space clearance is required.
- Have fireplace and selected vent components on hand to help determine the exact measurements when elbowing or offsetting. Always use wall firestops when penetrating walls and firestops when penetrating ceilings or attic spaces.
- For installation of fireplace at elevations of 4000 feet or greater, pay special attention to venting requirement recommendations.

**⚠ WARNING: Read all instructions completely and thoroughly before attempting installation. Failure to do so could result in serious injury, property damage or loss of life.**

**NOTICE: Failure to follow these instructions will void the warranty.**

**NOTICE: Do not seal termination cap to vent pipe. Cap must be removable for vent inspection and maintenance.**

### INSTALLATION PRECAUTIONS

- Wear gloves and safety glasses for protection
- Use extreme caution when using ladders or when on roof tops
- Be aware of electrical wiring locations in walls and ceilings

The following actions will void the warranty on your venting system:

- Installation of any damaged venting component
- Unauthorized modification of the venting system (Do not cut or alter vent components)
- Installation of any component part not manufactured or approved by FMI PRODUCTS, LLC
- Installation other than as instructed by these instructions

**⚠ WARNING: This gas fireplace and vent assembly must be vented directly to the outside. The venting system must NEVER be attached to a chimney serving a separate solid fuel burning appliance. Each direct vent gas appliance must use a separate vent system. Do not use common vent systems.**

**⚠ WARNING: Vent pipe air space clearances to combustibles are 1" on all sides except on the horizontal sections, which require 2" clearances from the top of the pipe. Where the termination cap penetrates a combustible wall, 1" air space clearance is required.**

# VENTING INSTALLATION

Continued

## INSTALLATION PLANNING

There are two basic types of direct vent installation:

- Horizontal Termination
- Vertical Termination

### Horizontal Termination Installation

**IMPORTANT:** Horizontal square terminations require only inner portion of wall firestop. Horizontal installations using round termination require exterior portion of wall firestop.

1. Set fireplace in its desired location and determine the route your horizontal venting will take. Do not secure fireplace until all venting has been installed. Some installations require sliding fireplace in and out of position to make final venting connections. Figures 11 and 12 on page 13 show different configurations for venting with horizontal termination that will help you decide which application best suits your installation. Check to see if wall studs or roof rafters are in the path of your desired venting route. If they are, you may want to adjust location of fireplace.

2. Direct vent pipe sections and components are designed with special twist-lock connections.

**Twist-Lock Procedure:** Female ends of pipes have locking lugs (indentations). These lugs will slide straight into matching slots on male ends of adjacent pipes. Push pipe sections together and twist one section clockwise approximately one-quarter turn until sections are fully locked (see Figure 8).

*Note: Horizontal runs of vent must be supported every three feet. Use wall straps for this purpose.*

3. Assemble desired combination of pipe and elbows to fireplace flue collar. If there are long portions of venting run, pre-assembled pipe sections may be installed as subassemblies for convenience.
4. Carefully determine location where vent pipe assembly will penetrate outside wall. Center of hole should line up with center line of horizontal vent pipe. Mark wall for an 11 1/2" x 11 1/2" square hole. Cut and frame square hole in exterior wall where vent will be terminated. If wall being pen-

etrated is constructed of noncombustible material, such as masonry block or concrete, a 8 1/2" hole with zero clearance is acceptable (see Figure 9).

**WARNING:** Do not recess vent termination into any wall. This will cause a fire hazard.

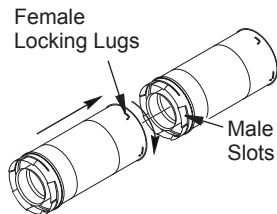

Figure 8 - Vent Pipe Connections

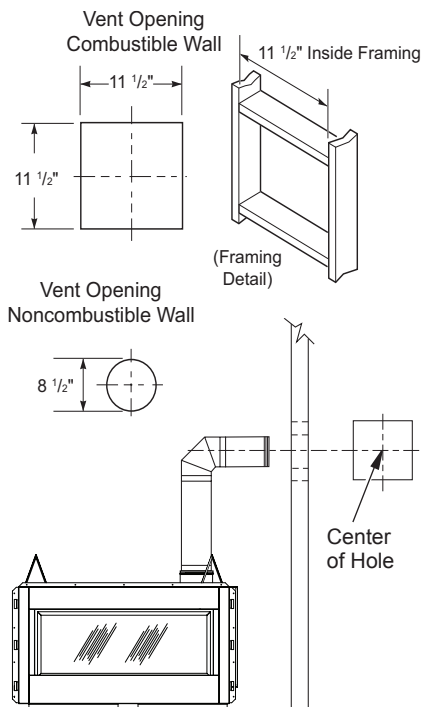

Figure 9 - Vent Opening Requirements

# VENTING INSTALLATION

*Continued*

5. **Noncombustible Exterior Wall:** Position horizontal vent cap in center of the 8 1/2" round hole and attach to exterior wall with four wood screws provided. Before attaching vent cap to exterior wall, run a bead of non-hardening mastic (pliable sealant) around outside edges to make a seal between it and outside wall.

*Note: Four wood screws provided should be replaced with appropriate fasteners for stucco, brick, concrete or other types of sidings (see Figure 10).*

**Combustible Exterior Wall:** For vinyl siding, stucco or wood exteriors, a siding standoff may be installed between vent cap and exterior wall. Siding standoff prevents excessive heat from damaging siding materials. Siding material must be cut to accommodate standoff. Bolt vent cap to standoff. Apply non-hardening mastic around outside edge of standoff. Position standoff/cap assembly in the center of 11 1/2" square hole and attach to exterior wall with provided wood screws (see Figure 11). Siding standoff must sit flush against exterior fascia material.

6. **Connecting Vent Cap with Horizontal Vent Pipe:** Slide wall firestop over vent pipe before connecting horizontal run to vent cap (see Figure 12).

Carefully move fireplace, with vent assembly attached, toward wall and insert vent pipe into horizontal termination. Pipe overlap should be a minimum of 1 1/4" (see Figure 13, page 14).

Slide wall firestop against interior wall surface and attach with screws provided. See Figure 13, page 14, for horizontal termination details.

Place fireplace into position and shim with noncombustible material if needed. Nail or screw side flanges to framing to secure unit in place. **IMPORTANT:** Make sure fireplace is level before securing. If fireplace is not level it will not work properly.

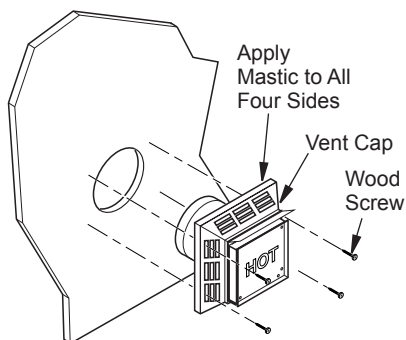

**Figure 10 - Installing Horizontal Vent Cap (Noncombustible Exterior)**

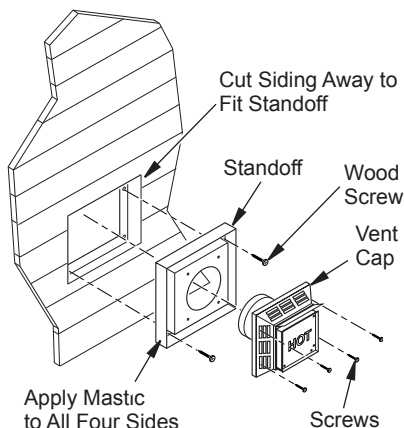

**Figure 11 - Installing Siding Standoff (Combustible Exterior Wall)**

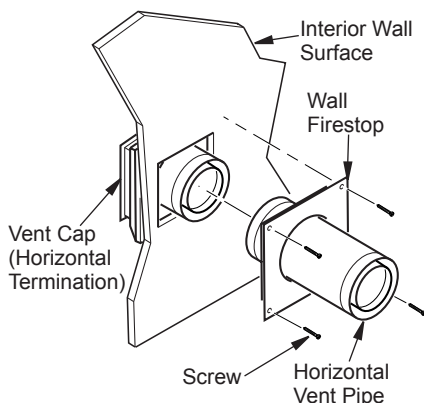

**Figure 12 - Connecting Vent Cap with Horizontal Vent Pipe**

# VENTING INSTALLATION

*Continued*

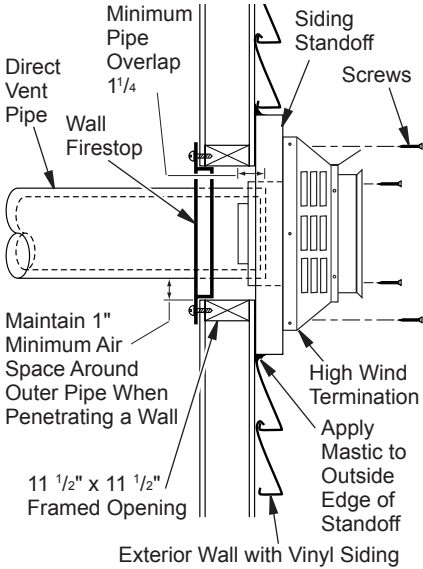

**Figure 13 - Typical Horizontal Termination Cap Mounting with Additional Siding Standoff Installed**

## Horizontal Termination Configurations

Figure 14 and 15, page 15, shows the configurations for venting with horizontal termination with a chart of critical minimum and maximum dimensions which **MUST** be met.

**NOTICE: Do not seal termination cap to vent pipe. Cap must be removable for vent inspection and maintenance.**

**⚠ WARNING: Never run vent downward as this may cause excessive temperatures which could cause a fire. Operation of improperly installed and maintained venting system could result in serious injury, property damage or loss of life.**

# VENTING INSTALLATION

Continued

## GROUND FLOOR INSTALLATION

Recommended Applications:

- Through the wall using round or square termination

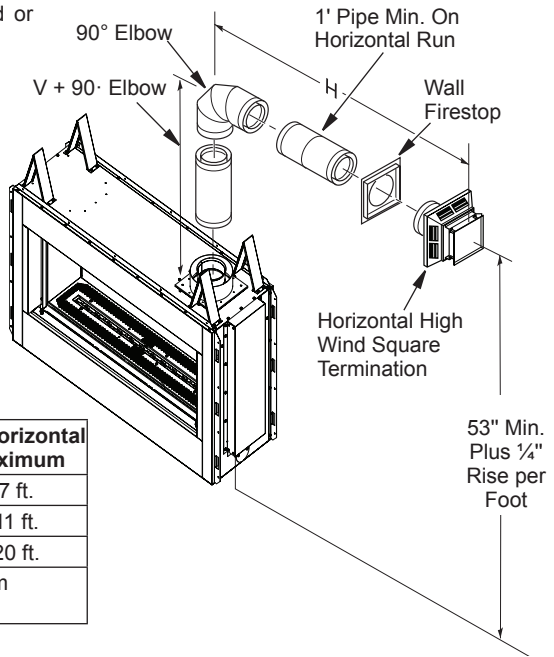

(V) Vertical Minimum	Required Vertical Pipe	(H) Horizontal Maximum
53"	1 ft.	7 ft.
65"	2 ft.	11 ft.
77"	3 ft.	20 ft.
V + H = 40 feet maximum		
H = 20 feet maximum		

Figure 14 - Horizontal Termination Using One 90° Elbow

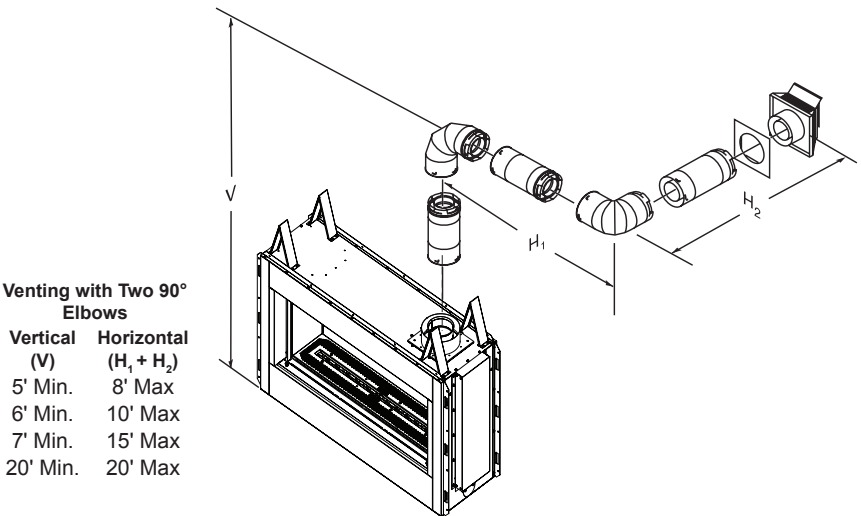

Figure 15 - Horizontal Termination Using Two 90° Elbows

# VENTING INSTALLATION

*Continued*

## Vertical High Wind Termination Installation

*Note: Vertical restrictor must be installed in all vertical installations.*

1. Determine route your vertical venting will take. If ceiling joists, roof rafters or other framing will obstruct venting system, consider an offset (see Figure 16) to avoid cutting load bearing members. *Note: Pay special attention to these installation instructions for required clearances (air space) to combustibles when passing through ceilings, walls, roofs, enclosures, attic rafters, etc. Do not pack air spaces with insulation. Also note maximum vertical rise of venting system and any maximum horizontal offset limitations.*
2. Set fireplace in desired location. Drop a plumb line down from ceiling to position of fireplace exit flue. Mark center point where vent will penetrate ceiling. Drill a small locating hole at this point.
3. Drop a plumb line from inside of roof to locating hole in ceiling. Mark center point where vent will penetrate roof. Drill a small locating hole at this point.

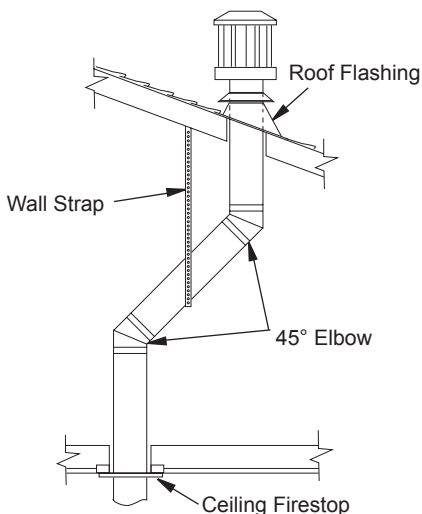

**Figure 16 - Offset with Wall Strap and 45° Elbows**

## Vent Termination Chart

Roof Pitch	Minimum Height Feet Min.
Flat to 6/12	1
6/12 to 7/12	1.25
Over 7/12 to 8/12	1.5
Over 8/12 to 9/12	2
Over 9/12 to 10/12	2.5
Over 10/12 to 11/12	3.25
Over 11/12 to 12/12	4
Over 12/12 to 14/12	5
Over 14/12 to 16/12	6
Over 16/12 to 18/12	7
Over 18/12 to 20/12	7.5
Over 20/12 to 21/12	8.0

## Flat Ceiling Installation

1. Cut a 11 1/2" square hole in ceiling using locating hole as a center point. Opening should be framed to 11 1/2" x 11 1/2" inside dimensions, as shown in Figure 9 on page 12 using framing lumber the same size as ceiling joists. If area above ceiling is an insulated ceiling or an attic, nail firestop from top side. This prevents loose insulation from falling into required clearance space. If area above ceiling is a living space, install firestop below framed hole. Firestop should be installed with no less than three nails per side (see Figure 17).

If area above is an attic or insulated area, install firestop above framed hole.

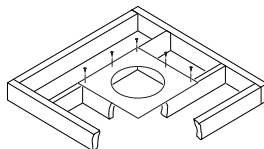

If area above is a living space, install firestop below framed hole.

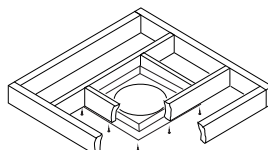

**Figure 17 - Installing Firestop**



# VENTING INSTALLATION

*Continued*

- Assemble desired lengths of pipe and elbows necessary to reach from fireplace flue up through firestop. Be sure all pipe and elbow connections are fully twist-locked (see Figure 8, page 12).
- Cut a hole in the roof using locating hole as a center point. (Cover any exposed open vent pipes before cutting hole in roof.) The 11 1/2" x 11 1/2" hole must be measured on the horizontal; actual length may be larger depending on pitch of roof. There must be a 1" clearance from vent pipe to combustible materials. Frame opening as shown in Figure 9 page 12.

- Connect a section of pipe and extend up through hole.

*Note: If an offset is needed to avoid obstructions, you must support vent pipe every 3 feet. Use wall straps for this purpose (see Figure 14, page 15). Whenever possible, use 45° elbows instead of 90° elbows. The 45° elbow offers less restriction to the flow of flue gases.*

- Place flashing over pipe section(s) extending through roof. Secure base of flashing to roof and framing with roofing nails. Be sure roofing material overlaps top edge of flashing as shown in Figure 16. There must be a 1" clearance from vent pipe to combustible materials.
- Continue to add pipe sections until height of vent cap meets the minimum building code requirements described in Figure 7 on page 10.

*Note: You must increase vent height for steep roof pitches. Nearby trees, adjoining rooflines, steep pitched roofs and other similar factors may cause poor draft or down-drafting in high winds. Increasing vent height may solve this problem.*

- Twist-lock vent cap onto last section of vent pipe.

*Note: If vent pipe passes through any occupied areas above first floor, including storage spaces and closets, you must enclose pipe. You may frame and sheetrock enclosure with standard construction material. Make sure and meet the minimum allowable clearances to combustibles. Do not fill any required air spaces with insulation.*

## Vertical Termination Configurations

Figure 17 and 18, page 17 and 18, shows the configurations for vertical termination.

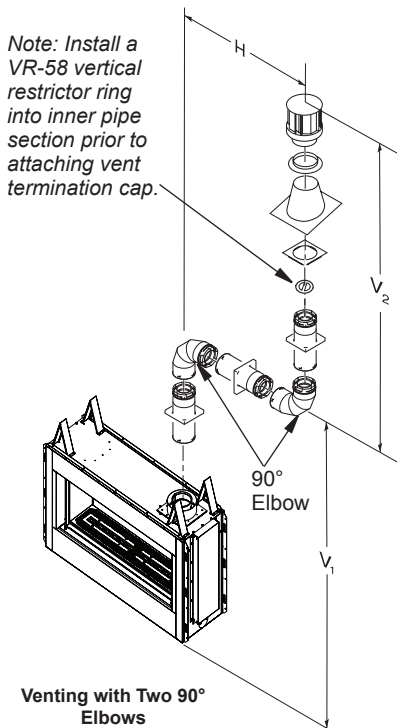

### Venting with Two 90° Elbows

Vertical (V <sub>1</sub> )	Horizontal (H)
5' Min.	10' Max
6' Min.	14' Max
7' Min.	20' Max
20' Max.	20' Max

*Note: Vertical (V<sub>1</sub>) + Vertical (V<sub>2</sub>) = 20' Max.  
V + H = 40' Max.  
H=20' Max.*

**Figure 18 - Vertical Venting Configuration Using Two 90° Elbows**

# VENTING INSTALLATION

*Continued*

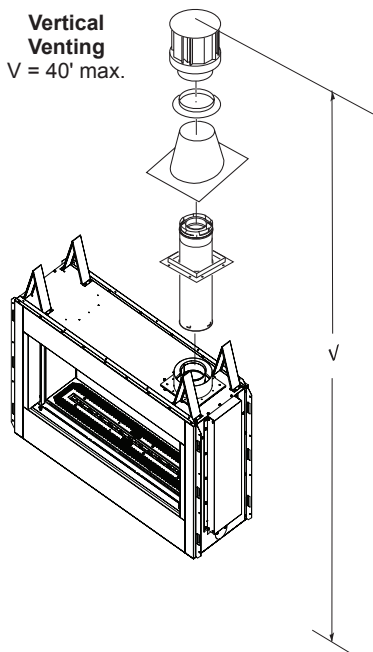

## PARTS LIST FOR VENTING KITS AND COMPONENTS

FMI PRODUCTS, LLC (5/8") Pipe & Vent Kits

<u>Number</u>	<u>Description</u>
P58-6	6" Section Double Wall Pipe, Galvanized
P58-12	12" Section Double Wall Pipe, Galvanized
P58-24	24" Section Double Wall Pipe, Galvanized
P58-36	36" Section Double Wall Pipe, Galvanized
P58-48	48" Section Double Wall Pipe, Galvanized
PA58-712	Adjustable 7"-12" Section Double Wall Pipe, Galvanized
E58-45	45° Elbow, Galvanized
E58-90	90° Elbow, Galvanized
HTS-58	Horizontal Square Termination, Galvanized
HHT-58	High Wind Round Termination, Galvanized
VT-58	Vertical Round Termination, Galvanized
SC-58	Storm Collar, Galvanized
WF-58	Wall Firestop, Galvanized
RF-58-6	Roof Flashing - 0 to 6/12 Pitch, Galvanized
RF-58-12	Roof Flashing - 6/12 to 12/12 Pitch, Galvanized
VR-58	Vertical Restrictor, Galvanized
S-58	Vinyl Siding Standoff, Galvanized
WS-58	Wall Strap
CS-58	Cathedral Ceiling Support
FP-58	Firestop Plate
SF-58	Stucco Flashing - For use with HTS-58
RF-58	Flat Roof Flashing
PF58-957	Flex Vent 9" - 27"
PF58-1236	Flex Vent 12" - 36"
PF58-1854	Flex Vent 18" - 54"

**Figure 19 - Vertical Venting Configuration**

## HIGH ALTITUDE INSTALLATION

Your FMI PRODUCTS, LLC direct-vent fireplace has been tested and approved in the USA for elevations from 0-2000 feet (610 m) .

When installing this fireplace at an elevation above 2000 feet (610 m) (in the USA), you may need to decrease the input rating by changing the existing burner orifice to a smaller size. Reduce input 4% for each 1000 feet (305 m) above sea level. Check with your local gas company for proper derate procedure and orifice size.

When installing this fireplace at an elevation above 4500 feet (1372 m), check with local authorities.

For assistance with any high altitude installation call FMI PRODUCTS, LLC at 1-866-328-4537.

# FIREPLACE INSTALLATION

## CHECK GAS TYPE

Use proper gas type for the fireplace unit you are installing. If you have conflicting gas types, do not install fireplace. See retailer where you purchased the fireplace for proper fireplace according to your gas type.

## INSTALLING GAS PIPING TO FIREPLACE LOCATION

**⚠ WARNING:** A qualified service person must connect fireplace to gas supply. Follow all local codes.

**⚠ CAUTION:** For propane/LP units, never connect fireplace directly to the propane/LP supply. This heater requires an external regulator (not supplied). Install the external regulator between the fireplace and propane/LP supply.

**⚠ WARNING:** For natural gas, never connect fireplace to private (non-utility) gas wells. This gas is commonly known as wellhead gas.

## Installation Items Needed

Before installing fireplace, make sure you have the items listed below.

- external regulator (supplied by installer)
- piping (check local codes)
- sealant (resistant to propane/LP gas)
- equipment shutoff valve \*
- test gauge connection \*
- sediment trap
- tee joint
- pipe wrench
- approved flexible gas line with gas connector (if allowed by local codes)

\* An equipment shutoff valve with 1/8" NPT tap is an acceptable alternative to test gauge connection. Purchase the equipment shutoff valve from your retailer.

For propane/LP connection only, the installer must supply an external regulator. The external regulator will reduce incoming gas pressure. You must reduce incoming gas pressure to between 11" and 14" of w.c. pressure. If you do not reduce incoming gas pressure, fireplace regulator damage could occur. Install external regulator with the vent pointing down as shown in Figure 19. Pointing the vent down protects it from freezing rain or sleet.

**⚠ CAUTION:** Use only new, black iron or steel pipe. Internally-tinned copper tubing may be used in certain areas. Check your local codes. Use pipe of 1/2" diameter or greater to allow proper gas volume to fireplace. If pipe is too small, undue loss of volume will occur.

Installation must include an equipment shutoff valve, union and plugged 1/8" NPT tap. Locate NPT tap within reach for test gauge hook up. NPT tap must be upstream from fireplace (see Figure 21, page 20).

**IMPORTANT:** Install main gas valve (equipment shutoff valve) in an accessible location. The main gas valve is for turning on or shutting off the gas to the appliance.

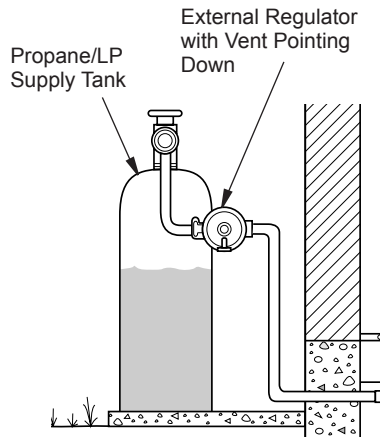

**Figure 20 - External Regulator with Vent Pointing Down (Propane/LP Only)**

# FIREPLACE INSTALLATION

Continued

Check your building codes for any special requirements for locating equipment shutoff valve to fireplaces.

Apply pipe joint sealant lightly to male NPT threads. This will prevent excess sealant from going into pipe. Excess sealant in pipe could result in clogged fireplace valves.

**⚠ WARNING: Use pipe joint sealant that is resistant to liquid petroleum (LP) gas.**

We recommend that you install a sediment trap/drip leg in supply line as shown in Figure 21. Locate sediment trap/drip leg where it is within reach for cleaning. Install in piping system between fuel supply and fireplace. Locate sediment trap/drip leg where trapped matter is not likely to freeze. A sediment trap traps moisture and contaminants. This keeps them from going into fireplace gas controls. If sediment trap/drip leg is not installed or is installed wrong, fireplace may not run properly.

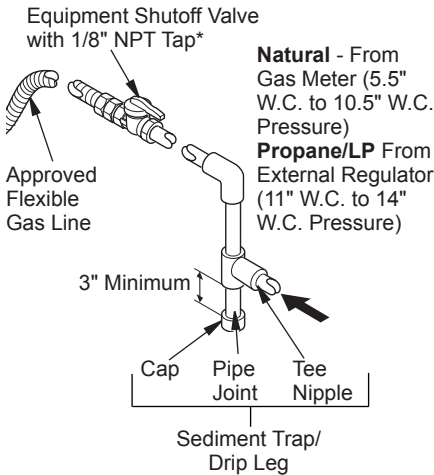

**Figure 21 - Gas Connection**

\* The equipment shutoff valve may be supplied with the appliance or you can purchase it from your retailer.

## CONNECTING FIREPLACE TO GAS SUPPLY

### Installation Items Needed

- 5/16" hex socket wrench or nut-driver
  - sealant (resistant to propane/LP gas, not provided)
1. Route flexible gas line (provided by installer) from equipment shutoff valve to fireplace. Route flexible gas supply line through one of the access holes on side of fireplace.
  2. Attach flexible gas line from gas supply to control valve (see Figure 22).
  3. Check all gas connections for leaks. See Checking Gas Connections, page 21.

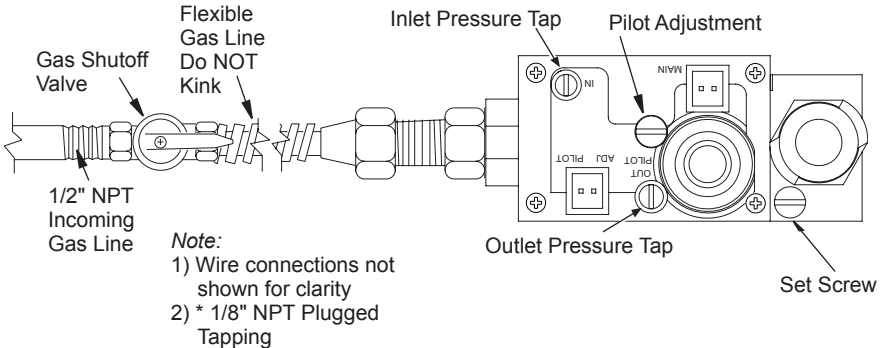

**Figure 22 - Connecting Incoming Gas Line to Flex Gas Line**

# FIREPLACE INSTALLATION

*Continued*

## CHECKING GAS CONNECTIONS

**⚠ WARNING: Test all gas piping and connections, internal and external to unit, for leaks after installing or servicing. Correct all leaks at once.**

**⚠ WARNING: Never use an open flame to check for a leak. Apply noncorrosive leak detection fluid to all joints. Bubbles forming show a leak. Correct all leaks at once.**

## PRESSURE TESTING GAS SUPPLY PIPING SYSTEM

**Test Pressures In Excess Of 1/2 PSIG (3.5 kPa)**

1. Disconnect fireplace and its individual equipment shutoff valve from gas supply piping system. Pressures in excess of 1/2 psig (3.5 kPa) will damage fireplace gas regulator.
2. Cap off open end of gas pipe where equipment shutoff valve was connected.
3. Pressurize supply piping system by either opening propane/LP supply tank valve for propane/LP gas fireplace or opening main gas valve located on or near gas meter for natural gas fireplace or using compressed air.
4. Check all joints of gas supply piping system. Apply noncorrosive leak detection fluid to all joints. Bubbles forming show a leak. Correct all leaks at once.
5. Reconnect fireplace and equipment shutoff valve to gas supply. Check reconnected fittings for leaks.

**Test Pressures Equal To or Less Than 1/2 PSIG (3.5 kPa)**

1. Close equipment shutoff valve (see Figure 23).
2. Pressurize supply piping system by either opening propane/LP supply tank valve for propane/LP gas fireplace or opening main gas valve located on or near gas meter for natural gas fireplace or using compressed air.

3. Check all joints from propane/LP supply tank or gas meter to equipment shutoff valve (see Figure 24 or Figure 25). Apply noncorrosive leak detection fluid to all joints. Bubbles forming show a leak.
4. Correct all leaks at once.

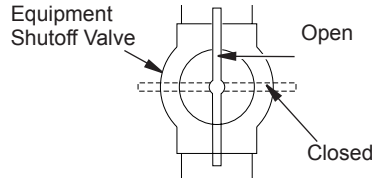

**Figure 23 - Equipment Shutoff Valve**

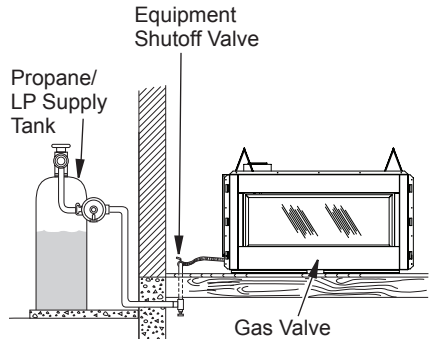

**Figure 24 - Checking Gas Joints for Propane/LP Gas Fireplace**

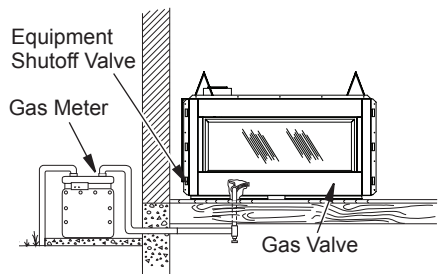

**Figure 25 - Checking Gas Joints for Natural Gas Fireplace**

## PRESSURE TESTING FIREPLACE GAS CONNECTIONS

1. Open equipment shutoff valve (see Figure 23).
2. Open propane/LP supply tank valve for propane/LP fireplace or main gas valve located on or near gas meter for natural gas fireplace.

# FIREPLACE INSTALLATION

*Continued*

3. Make sure control knob of fireplace is in the OFF position.
4. Check all joints from equipment shutoff valve to gas valve (see Figure 24 or Figure 25, page 21). Apply noncorrosive leak detection fluid to all joints. Bubbles forming show a leak. Correct all leaks at once.
5. Light fireplace (see *Operation*, page 26). Check all other internal joints for leaks.
6. Turn off fireplace (see *To Turn Off Gas to Appliance*, page 27).

## FINISHING FIREPLACE FOR INSTALLATION

(V)LDV43 series fireplace come with the rear panel semi-installed. If you will be using the fireplace for a one sided regular application, you will need to finish the installation of the rear panel. If you will be upgrading the fireplace to a see-thru, the rear panel will need to be removed (See *Upgrading (V)LDV43 Series to See-Thru Application* page 23).

1. Using self-tapping screws provided and holes on rear panel as a guide, screw the rear panel to the fireplace as shown in Figure 26.

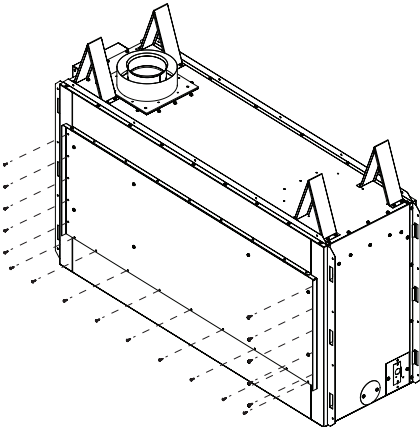

**Figure 26 - Installing Rear Panel for Regular Applications**

## REMOVING/REPLACING GLASS DOOR

**⚠ CAUTION:** Do not operate this fireplace with a broken glass door panel or without the glass door panel securely in place. For replacement part information see *Parts*, page 38.

**⚠ CAUTION:** Wear gloves and safety glasses while handling or removing broken glass. Do not remove if glass is hot. Keep children and pets away from glass.

**⚠ WARNING:** If fireplace has been running, turn off fireplace. Let cool before removing glass doors.

### Removing Glass Door

If replacement of glass is necessary, the entire frame assembly must be replaced. Gloves must be worn when removing/replacing glass door. If glass is broken tape remaining glass onto frame before removing.

1. Remove bottom access panel.
2. Unlock 3 door latches on top of firebox using your fingers or the latch opener provided.
3. Hook opener over latch as shown in Figure 27. Swing the bottom of the opener down toward the door. You will not need to pull down.
4. Tilt open glass door 45° from the top of firebox and lift up to release door from retaining channel (see Figure 28, page 23).

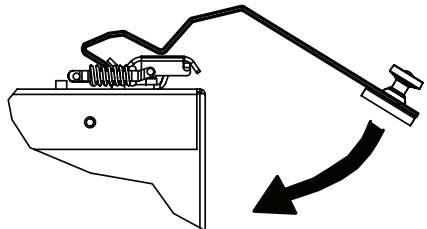

**Figure 27 - Latch Opener**

# FIREPLACE INSTALLATION

*Continued*

## Replacing Glass Door

1. Position door frame in front of firebox opening tilting top of door about 45° toward you. Insert bottom flange of glass door into the retaining channel at the bottom of firebox (see Figure 28). Make sure door is center with firebox opening.
2. Tilt top of door up toward top of firebox.
3. Secure 3 top door latches.

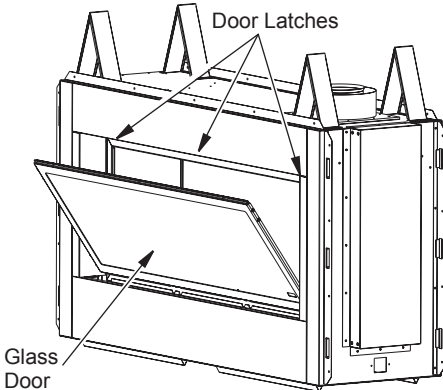

Figure 28 - Removing/Replace Glass Door

## GLOWING EMBERS AND GLASS PEBBLE INSTALLATION

**⚠ WARNING:** Do not change or substitute glass pebbles provided with this fireplace. If replacing, use only replacement glass pebbles. See Replacement Parts page 42.

**⚠ WARNING:** Do not block pilot ports with embers.

Glowing embers and glass pebbles are included with your fireplace. Install these items while glass doors are open and/or removed.

1. Place glass pebbles in a single layer evenly on the pebble pan. Make sure not to place any on the burner in the center of the pebble pan or on the pilot.
2. Pull glowing ember material apart into pieces no larger than a dime. Place these pieces loosely and sparingly directly onto exposed burner ports. This will create the glowing ember appearance as flame

touches ember material. Do not block air slots by using too much ember material in one area. Do not block pilot ports with embers. It is not necessary to use all of the glowing ember material provided.

## UPGRADING (V)LDV43 TO SEE-THRU APPLICATION

### Removing Rear Panel

1. In the rear of the fireplace, locate screws at top of rear panel and remove as shown in Figure 29. Discard screws and rear panel.
2. Unscrew mount bracket from top face as shown in Figure 30. Discard mounting bracket and replace screws.

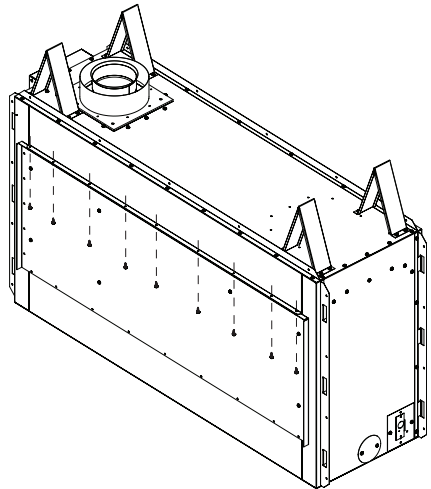

Figure 29 - Removing Rear Panel for See-Thru Applications

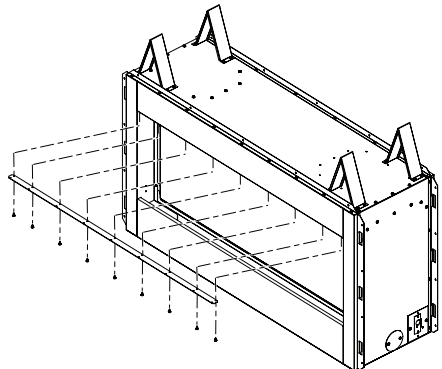

Figure 30 - Removing for See-Thru Applications

# FIREPLACE INSTALLATION

Continued

## Removing False Door

1. In the rear of the fireplace, remove false door just as you would remove the front glass door. Refer to *Removing/Replacing Glass Door*, page 22 of this manual for instruction. Discard false door.

## Removing Rear Interior Wall

1. Remove glass door from front of fireplace. Refer to *Removing/Replacing Glass Door*, page 22 of this manual when removing glass door.
2. Unscrew 4 corner brackets from the firebox top (See Figure 31).
3. Remove 2 side walls and then the rear wall. Discard rear wall.
4. Replace 2 side walls and reinstall the corner brackets.
5. Reinstall front glass door.

## Installing Second Glass Door

1. Install second glass door in the rear of the fireplace refer to *Removing/Replacing Glass Door*, page 22 of this manual.

## Installing Access Door Retaining Brackets

1. Screw access door retaining brackets into the inner side face using 2 screws on both the left and right side as shown in Figure 32.

## Installing Side Face Filler

1. Screw side face filler into firebox side baffle using 2 screws on both the left and right side as shown in Figure 33.

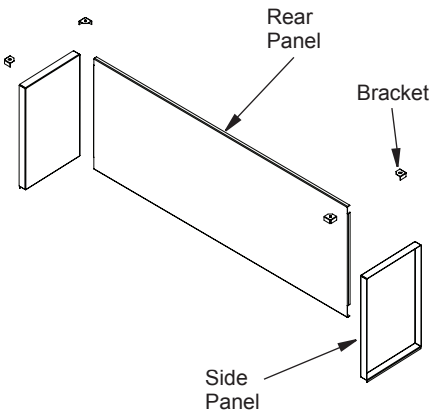

Figure 31 - Removing Rear Interior Wall for See-Thru Applications

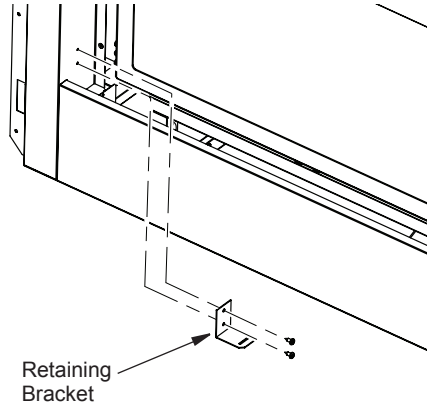

Figure 32 - Installing Access Door Retaining Brackets for See-Thru Applications

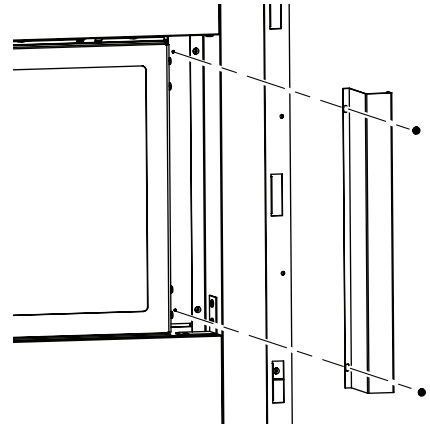

Figure 33 - Installing Side Face Filler for See-Thru Applications

## Installing Access Door

1. Place access door into rectangular opening in front of the glass door with the slanted side facing forward. The slanted surface will slide underneath the flange of the bottom face. Insert tabs on side of access door into slots on retaining brackets (See Figure 34, page 25).



# FIREPLACE INSTALLATION

*Continued*

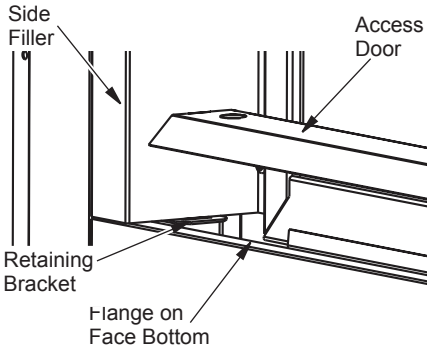

**Figure 34 - Access Door for See-Thru Applications**

- You may choose to drill pilot holes into the face using a 1/8" drill bit. Do not use self tapping screws, use any #10 x 1/2" screw.
- In locations of extreme weather, it is recommended to apply a bead of high temperature sealant around the edge where the exterior door meets the fireplace face.

**NOTE:** When finishing the face of the exterior side of the fireplace, use only non-combustible materials. You may extend up to the edge of the exterior door covering up the screws used for installation.

## UPGRADING (V)LDV43 TO INDOOR/OUTDOOR SEE-THRU APPLICATION

**WARNING: LDSTI must be installed before installing LDSTO.**

### Installing Exterior Door

- Center and level exterior door on rear face of the see-thru fireplace. Exact dimensions for the location of the door are shown in Figure 35.
- Using self tapping screws (provided) secure exterior door to the face of the fireplace by drilling through holes on door into the fireplace face (Figure 36).

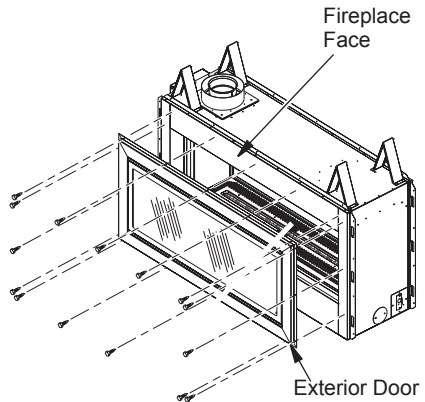

**Figure 36 - Installing Exterior Door for See-Thru In/Out Application**

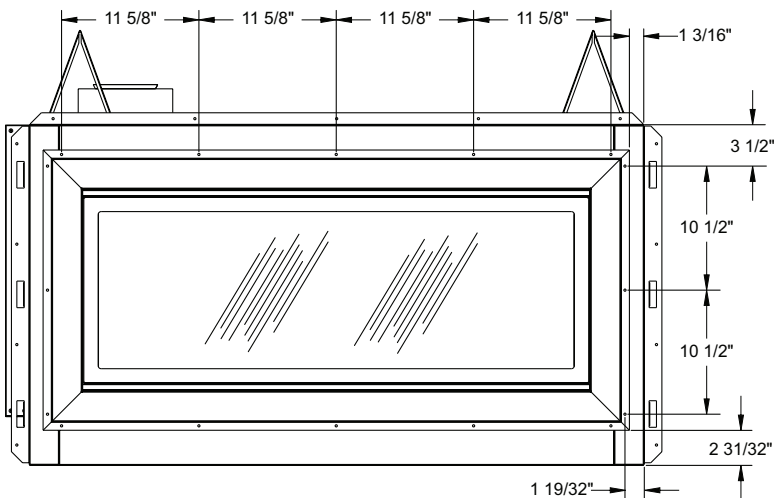

**Figure 35 - Installing Exterior Door for See-Thru In/Out Application**

# FIREPLACE INSTALLATION

*Continued*

## Removing Exterior Glass Door

1. Using a flat head screw driver, pop out the top and bottom trim pieces as shown in Figure 37.
2. Remove 8 screws at top and bottom of glass door and remove glass door.

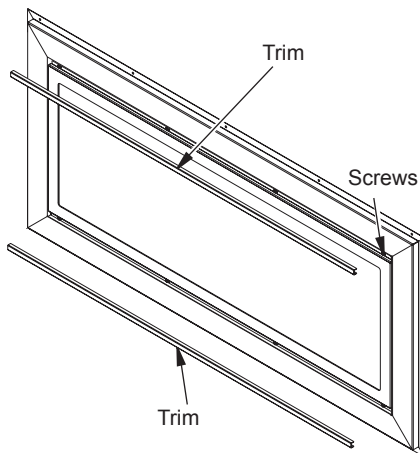

*Figure 37 - Removing Exterior Glass Door for Cleaning*

## OPERATION

**FOR YOUR SAFETY  
READ BEFORE LIGHTING**

**⚠ WARNING:** If you do not follow these instructions exactly, a fire or explosion may result causing property damage, personal injury or loss of life.

- A. This appliance is equipped with an ignition device which automatically lights the pilot. Do not light pilot by hand.
- B. **BEFORE LIGHTING** smell all around the appliance area for gas. Be sure to smell next to the floor because some gas is heavier than air and will settle on the floor.

### WHAT TO DO IF YOU SMELL GAS

- Do not try to light any appliance.
  - Do not touch any electric switch; do not use any phone in your building.
  - Immediately call your gas supplier from a neighbor's phone. Follow the gas supplier's instructions.
- C. Do not use this appliance if any part has been under water. Immediately call a qualified service technician to inspect the appliance and to replace any part of the control system and any gas control which has been under water.

**LIGHTING  
INSTRUCTIONS**

**NOTICE:** During initial operation of new fireplace, burning will give off a paper-burning smell. Orange flame will also be present. Open window to vent smell. This will only last a few hours.

1. STOP! Read the safety information in column 1.
2. Turn off all electric power to fireplace.
3. Turn safety shutoff switch to the OFF position.
4. Remove center brick/control cover.
5. Turn equipment shutoff valve clockwise ↻ to the OFF position (see Figure 38, page 27). Do not force.
6. Wait five (5) minutes to clear out any gas. Then smell for gas, including near the floor. If you smell gas, STOP! Follow "B" in the safety information. If you don't smell gas, go to the next step.
7. Turn equipment shutoff valve counter-clockwise ↻ to the ON position. Do not force.
8. Replace center brick/control cover.
9. Turn on all electric power to appliance.

## OPERATION

### Continued

10. Turn safety shutoff switch to the ON position.
11. Visually locate pilot. Ignitor should begin to spark and main burner should ignite once flame appears at pilot.
  - If lighting appliance for the first time each season, it may take several attempts before supply gas can reach pilot and main burners.
  - If appliance will not stay lit after several attempts, follow instructions under To Turn Off Gas To Appliance and call your service technician or gas supplier.

### TO TURN OFF GAS TO APPLIANCE

1. Turn off safety shutoff switch.
2. Turn off all electric power to appliance if service is to be performed.
3. Remove center brick/control cover.
4. Turn equipment shutoff valve clockwise  to OFF. Do not force.
5. Replace center brick/control cover.

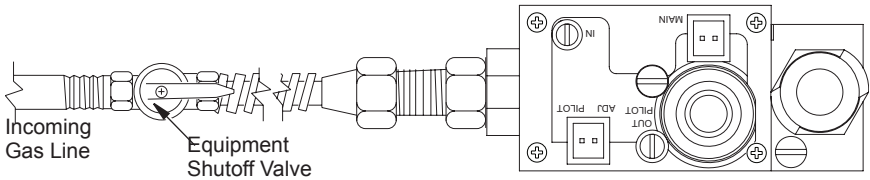

**Figure 38 - Turning Equipment Shutoff Valve to the OFF Position**

## INSPECTING BURNERS

Check pilot flame pattern and burner flame patterns often.

### PILOT ASSEMBLY

The pilot assembly is factory preset for the proper flame. Alterations may have occurred during shipping and handling. The pilot is located on right hand side of burner.

The flame must envelope 1/4" of top of the ignitor/sensor and grounding stem.

If your pilot assembly does not meet these requirements:

- Turn the adjustment screw marked PILOT clockwise to decrease or counterclockwise to increase the flame to proper size (see Figure 39). Do not remove the adjustment screw.
- see *Troubleshooting*, page 34

### BURNER FLAME PATTERN

Burner flames will be steady, not lifting or floating. Flame patterns will be different from unit to unit and will vary depending on installation type and weather conditions.

If the vent configuration is installed incorrectly, flames will lift or "ghost". This can be dangerous. Inspect flames after installation to ensure proper installation and performance.

If burner flame pattern differs from that described:

- turn fireplace off (see *To Turn Off Gas to Appliance*), page 27
- see *Troubleshooting*, page 34

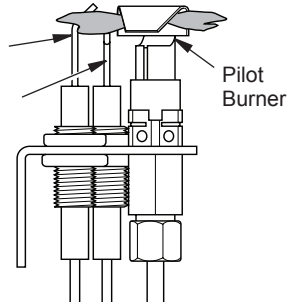

Figure 39 - Correct Pilot Flame Pattern

## CLEANING AND MAINTENANCE

**WARNING:** Turn off fireplace and let cool before cleaning.

**CAUTION:** You must keep control areas, burners and circulating air passageways of fireplace clean. Inspect these areas of fireplace before each use. Have fireplace inspected yearly by a qualified service person. Fireplace may need more frequent cleaning due to excessive lint from carpeting, bedding material, pet hair, etc.

### GLASS DOORS

**WARNING:** Handle glass door panels with care. Do not strike, slam or otherwise abuse glass. Do not operate fireplace with the glass door unlatched, removed, cracked or broken.

**WARNING:** Do not use abrasive cleaners as this may damage glass. Use a nonabrasive household glass cleaner to clean glass. Do not clean glass when hot.

Glass must be cleaned periodically. During start-up it is normal for condensation to form on the inside of the glass causing lint, dust and

## CLEANING AND MAINTENANCE

*Continued*

other airborne particles to cling to the glass surface. During initial start-up a slight film may form on the glass due to paint curing. The glass should be cleaned several times with a non-ammonia, nonabrasive household cleaner and warm water after the first two weeks of operation. Thereafter, clean the glass two or three times during each heating season, depending on the usage and circumstances present. Refer to *Removing/Replacing Glass Door*, page 22 of this manual when removing glass door for cleaning.

**⚠ WARNING: Only parts supplied by the manufacturer should be used when replacing broken or damaged glass door panels (see *Replacement Parts*, page 42). Glass door panel are complete units. No substitute materials may be used.**

**⚠ CAUTION: Wear gloves and safety glasses while handling or removing broken glass. Do not remove if glass is hot. Keep children and pets away from glass.**

If glass has been broken, carefully remove glass door (see *Removing/Replacing Glass Door*, page 22). Vacuum all glass pieces with a shop vac.

**⚠ CAUTION: Do not vacuum if pieces are hot.**

Use only glass door replacement intended for this fireplace (see *Replacement Parts*, page 42 for detail on ordering). No substitutions may be made. See *Removing/Replacing Glass Door*, page 22 for instructions for replacing glass doors.

**⚠ WARNING: Do not operate fireplace with glass door unlatched, removed, cracked or broken.**

### PILOT AND BURNERS

- Remove material before cleaning burners and replace when cleaning is complete.
- Burner and controls should be cleaned with compressed air to remove dust, dirt or lint.
- Use a vacuum cleaner or small, soft bristled brush to remove excess dust, dirt or lint.

### VENTING SYSTEM

Conduct annual inspection of the venting system following these guidelines:

1. Check areas of venting system that are exposed to the weather for corrosion (rust spots or streaks and, in extreme cases, holes). Have these items replaced immediately by a qualified service person.
2. Remove the vent cap and shine a flashlight into the vent. Remove any foreign material.
3. Check for evidence of excessive condensation. Continuous condensation can cause corrosion of caps, pipes and fittings and can be caused by having excessive lateral runs, too many elbows or exterior portions of the system being exposed to cold weather.
4. Inspect joints to verify that no pipe section or fitting has been disturbed and loosened. Check mechanical supports such as wall straps for rigidity.

## GAS CONTROL MODULE SYSTEM

The module has 2 special features built into the system.

### Continuous Pilot Feature

This allows the change from a spark to pilot system to a standing pilot system

1. There is a switch located on the right side of the module that reads CONTINUOUS PILOT ON/OFF. This switch selects the pilot's mode of operation (Figure 40).
2. When the continuous pilot switch is in the OFF position and the appliance rocker switch is turned ON, the pilot will spark and light. When the appliance rocker switch is turned OFF, the pilot will shut OFF when the main burner shuts OFF.
3. When the continuous pilot switch is in the ON position and the appliance rocker switch is turned ON, the pilot will spark and light. When the appliance rocker switch is turned OFF, the pilot will stay ON when the main burner shuts OFF.

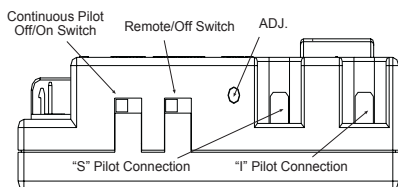

Figure 40 - Gas Module Right Side

### Remote Control Feature

The module has a built in remote control receiver that allows the user to program the remote transmitter at any time during or after the installation of the burner.

1. There is a switch located on the right side of the module that reads REMOTE/OFF (Figure 41).
2. When the remote/off switch is in the OFF position, the burner will operate from the rocker switch or wall switch connected to the two BROWN wires on the module.

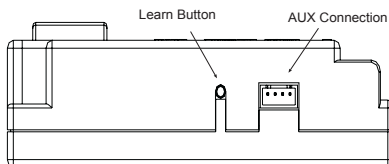

Figure 41 - Gas Module Left Side

3. When the remote/off is in the REMOTE position the burner will operate from the Remote Control transmitter.

NOTE: The module must be programmed to the Remote Control transmitter.

- To program the module (make sure the system has power), locate the learn button on left side as shown in Figure 41. Press and release the learn button. There will be a beep sound from the module. Then press any button on the remote transmitter. Once the module's internal receiver accepts the transmitter code, there will be a series of confirming beeps.
- The remote system is ready for use.

NOTE: Make sure the valve module and light module are plugged into the electric duct assembly.

### BATTERY BACK-UP

This fireplace is equipped with a battery back-up. If the power was to go out on the fireplace, the battery back-up allows the fireplace to remain operational. Make sure to periodically check the condition of the four AA batteries used for the battery back-up.

### REMOTE CONTROL OPERATION

The installation of the transmitter batteries, 2 AAA, will activate the initial set up of the system. Setup mode can also be activated at any time by pressing the FLAME REAR and PROG/TIME buttons simultaneously for 5 seconds. The control will automatically exit setup mode if no button is pressed within 20 seconds.

This system will allow the temperature unit conversion, gas type conversion, and clock set up while in Setup mode per the following setup procedure.

Setting of °C/°F conversion:

- °C/°F conversion: Use UP or DOWN key to choose Celsius or Fahrenheit, Press "SET" button to continue to gas type setup.

Clock Setup:

- Use UP or DOWN key to set HOUR, then press SET to enter "Minute" setting.
- Use UP or DOWN key to set "Minute", and then press SET to enter AM/PM setting.
- Use UP or DOWN key to set AM/PM, the press SET to enter day of week setting.
- Use UP or DOWN key to select the day of the week.

# GAS CONTROL MODULE SYSTEM

*Continued*

## Manual Mode

Push MODE button for manual ON, the flame ICON will come on the LCD screen. The second push of the MODE button will put the control into the THERMO mode. You can continue to push the MODE one more time to OFF.

Note: The MODE button will operate ON - THERMO - OFF in a series that will cycle from ON to THERMO to OFF.

## Light Mode

The control of the lighting output will be from a button on the handheld transmitter. When the LIGHT button is pressed, the LIGHT setting level will flash on the LCD display and the user can select desired setting from highest to lowest with 6 different levels to the lighting output via the UP and DOWN buttons. If no adjustment is made within 7 seconds, the control will exit the function setting mode and the LCD display will return to the normal view. The lights are completely independent of the main flame coming ON and OFF. The user can turn the lighting output ON or OFF regardless of the state of the main flame and changing the state of the main flame will have no effect on the lighting output.

The lights will be controlled with a separate module that will plug into the main control module with AUX communication port. This 4-pin system should control all the 120VAC components. The 120VAC plug in module will have two wires that are for the lighting and they should be 18 AWG 105C wires with 1/4" insulated connectors two males that will be two wires, length 6 "to 8" coming from the 120VAC module. The AC Neutral wire will be white and the AC Hot wire will be red. This 120VAC module will also control the fan; this is outlined within a separate section.

**The value of the vaultage are as follows:**

<u>Number of Pushes</u>	<u>Voltage Values</u>
6 (High)	100%
5	90%
4	80%
3	70%
2	60%
1 (Low)	50%
Off	0%

## Continuous Pilot

Operation of this feature of having the pilot to run all the time will be activated with the pressing of two buttons, "PROG/TIME" & "FLAME 1". This action will activate the Icon on the LCD screen. Pressing of the same two buttons will de-activate the feature.

This feature is the same as the standard AF-4000 module, but activation of the system is different in that two buttons must be depressed to activate or de-activate the function. This feature can also be activated via a 2-position switch on the side of the main module.

## Main Flame Modulation

The main flame modulation will use the step motor on the main gas valve.

The control of the main flame level will be from a button on the handheld transmitter. When the FLAME MAIN button is pressed, the main flame setting level will flash on the LCD display and the user can select desired setting from highest to lowest with 6 different levels via the UP and DOWN buttons. If no adjustment is made within 7 seconds, the control will exit the function setting mode and the LCD display will return to the normal view.

To allow for proper burner ignition the main flame will come on to the number 7 level, or the highest. After 5 seconds that system will turn the flame level to the last position before turning off. This will have to be in all modes of the operation, Manual, Thermo, and Program.

## Countdown Timer

The timer function is like the 1001LCD in that you will have up to 3 hours of countdown time for the fireplace to run and can be operated in both Manual and Thermal modes.

Once you have pressed the timer button the "TIMER" name under the clock will start to flash at 10 minutes as the start point. The user can change the time from 10 minutes to 180 minutes, 10 minutes segments. If no adjustment is made within 7 seconds, the control will accept the 10 minute setting, exit the function setting mode, and the LCD display will return to the normal view.

Pushing "TIMER" button, you can set the flashing clock with the "TIMER" under the clock area.

You can press the "up" or the "down" to set your desired TIMER segment.

# GAS CONTROL MODULE SYSTEM

## Continued

Once the timer is set to the desired number of minutes the number will flash for another 7 seconds and then go into the timer setting and start to count down.

The user can press the "SET" button and the system will immediately start the TIMER function.

If the "TIMER" button is pressed again while the timer is counting down the "TIMER" will be terminated.

If the OFF mode is activated the "TIMER" will be terminated. OFF is OFF in all cases.

### Thermo Mode

Selection of the THERMO or Thermostat mode with the MODE button will light the smaller SET window of numbers. The first SET number will be 45F, and with UP or DOWN keys you can SET the temperature that the user would like the room to maintain. Once the SET temperature is correct, within 5 seconds of time, the appliance will operate to that Set Temperature.

The flame ICON and ON & THERMO will be on the LCD screen. At this point the appliance will be burning. The user will not have to operate the "SET" button to set the temperature. But if the SET button is pushed, it also completes the process for setting temperature.

You can use DOWN or UP buttons to obtain a new desired temperature. Simply use the UP and Down buttons to set the new temperature and the appliance, within 5 seconds, will turn ON or OFF and will still show THERMO on the LCD screen

Another short push of this MODE button will cancel the THERMO function. In another words, a short push of MODE button will deactivate THERMO function, and the appliance will be OFF.

The control will have an additional feature to the thermostat control with flame modulation as the set temperature is obtained.

The outline of the turn down will be based on the degrees under the setting temperature. The coding will be like the following.

Set Temperature will be from 45F to 99F

The flame modulation will have six levels from highest to lowest on the main fireplace burner, that is controlled with a step motor on the gas valve.

NOTE: The flame control will obtain the following information from the handheld control. It is very important to remember that our factory setting of SWING TEMPERATURE is 2 degrees. Addition of this feature will not allow this SWING to be change as with current designs.

### SET TEMPERATURE

<u>Example</u>	<u>Flame Level</u>
74 °F	OFF
73 °F	1
72 °F	2
71 °F	3
70 °F	4
69 °F	5
68 °F	6
67 °F	7

### Program Mode

A short push of (PROG/ TIME) button will select/operate or de-activate the PROGRAM mode. A long push (push & hold for more than 5 seconds) of this button will enter into the Setting of PROGRAM mode.

Following are the Factory setting for the PROGRAM mode:

### M T W T F

Segment 1(P1)	ON - 7:00am OFF - 9:00am
Segment 2(P2)	ON - 5:00pm OFF - 8:00pm

### SS

Segment 1(P1)	ON - 9:00am OFF - 10:00am
Segment 2(P2)	ON - 6:00pm OFF - 9:00pm



# GAS CONTROL MODULE SYSTEM

*Continued*

Following is the set up for the Program Mode:  
Push & hold button for more than 2 seconds  
to enter the setting for program mode:

**MTWTF&** **P1**  & **88:88** **AM** **PM** |  
on LCD will flash, then you can use UP or  
DOWN keys to change the setting of "P1  
ON". Then you push SET button to enter  
into next setting.

**MTWTF&** **P1**  & **88:88** **AM** **PM** |  
on LCD will flash, then you can use UP or  
DOWN to change the setting of "P1 OFF".  
Then, push SET button to enter into next  
setting.

**MTWTF&** **P2**  & **88:88** **AM** **PM** |  
on LCD will flash, then you can use UP or  
DOWN to change the setting of "P2 ON".  
Then, use SET button to enter into next  
setting.

**MTWTF&** **P2**  & **88:88** **AM** **PM** |  
on LCD will flash. Then use UP or DOWN to  
change the setting of "P2 OFF". Then, push  
SET button to enter into next setting.

**SS&** **P1**  & **88:88** **AM** **PM** |  
on LCD will flash, then you can use UP or  
DOWN keys to change the setting of "P1  
ON". Then you push SET button to enter  
into next setting.

**SS&** **P1**  & **88:88** **AM** **PM** |  
on LCD will flash, then you can use UP or  
DOWN to change the setting of "P1 OFF".  
Then, push SET button to enter into next  
setting.

**SS&** **P2**  & **88:88** **AM** **PM** |  
on LCD will flash, then you can use UP or  
DOWN to change the setting of "P2 ON".  
Then, use SET button to enter into next  
setting.

**SS&** **P2**  & **88:88** **AM** **PM** |  
on LCD will flash. Then use UP or DOWN to  
change the setting of "P2 OFF". Then, push  
SET button to enter into next setting.

**NOTE:** The "flashing" stated above for the  
PROGRAM setting will only last for 2 Min-  
utes. If SET (or any other buttons) button  
is not pushed within this period, the system  
will automatically complete the "PROG/TIME  
setting" process and LCD will go back to its  
normal readouts.

### IMPORTANT NOTE TO UNDERSTAND:

The control of the appliance will be under the  
SET TEMPERATURE of the thermostat. If the  
set temperature is at "45F" as it comes from  
the factory, the appliance will not turn ON if  
the room is not below that set temperature. If  
the set temperature is at "70F" the appliance  
will come on only if this temperature is the  
room is below "70F". The mode of this trans-  
mitter can be in OFF or THERMO and the  
PROGRAM will still operate.

### CHILD PROOF

This feature is to be activated/de-activated  
by pushing PROG/TIME & UP keys at the same  
time for more than 5 seconds..

When this feature is activated, the "CP" will  
appear in the Room Temperature Window for  
approximately 5 seconds. "CP" will then be  
displayed in the Room Temperature Window  
whenever a transmitter button is pressed and  
no signal will be transmitted.

## TROUBLESHOOTING

**⚠ WARNING:** Turn off fireplace and let cool before servicing. Only a qualified service person should service and repair fireplace.

**⚠ CAUTION:** Never use a wire, needle or similar object to clean pilot. This can damage pilot unit.

*Note: All troubleshooting items are listed in order of operation.*

OBSERVED PROBLEM	POSSIBLE CAUSE	REMEDY
Pilot will not light	<ol style="list-style-type: none"><li>1. No gas supply or shutoff valve is OFF</li><li>2. Air in gas line</li><li>3. Construction debris clogging pilot orifice</li><li>4. Low gas pressure</li><li>5. Kinked pilot line</li><li>6. Control valve is not opening</li><li>7. No power to unit or ignition module</li></ol>	<ol style="list-style-type: none"><li>1. Check to see if you have gas supply and that equipment shutoff valve is opened</li><li>2. Repeat lighting procedure several times to purge all air out of lines. If after repeated attempts appliance does not light, call for qualified service and repair</li><li>3. Remove debris and dirt, inspect and clean any other possible obstructions</li><li>4. Contact your gas supplier to check pressure</li><li>5. Have a qualified technician replace pilot line</li><li>6. Replace control valve (Refer to <i>Replacement Parts</i>, page 42)</li><li>7. Check that main power is on and that all wire connections are made correctly to ignition model (see <i>Wiring Diagram</i>, page 37).</li></ol>

# TROUBLESHOOTING

*Continued*

<b>OBSERVED PROBLEM</b>	<b>POSSIBLE CAUSE</b>	<b>REMEDY</b>
Pilot will not stay lit	<ol style="list-style-type: none"><li>1. Loose wiring on ignitor wire to ignition module and/ or poor ground to ignition module</li><li>2. Main burner does not come on when manual switch or remote control is turned on.</li></ol>	<ol style="list-style-type: none"><li>1. Confirm the "S" wire and the "I" wire are properly connected to the module in the proper "S" and "I" terminals. Confirm that the spark to the pilot burner is properly grounded to the gas control valve and to the module. Check the 110 volt power source or the 6 volt battery back-up connections and condition of batteries. Check the position of the CONTINUOUS PILOT switch on the module.</li><li>2. Confirm the pilot is sparking and lights. Check the two plastic connectors that plug in the face of the gas control valve. Confirm the gas control valve is properly grounded to the module.</li></ol>
No gas to burner, although safety shutoff switch and valve are set to the ON position	<ol style="list-style-type: none"><li>1. Safety shutoff switch wires defective or too long</li></ol>	<ol style="list-style-type: none"><li>1. Check electrical connections</li></ol>
Frequent pilot outage	<ol style="list-style-type: none"><li>1. Pilot flame may be too low, causing safety pilot to "drop out"</li><li>2. Improper venting or excessive blockage</li></ol>	<ol style="list-style-type: none"><li>1. Clean and adjust pilot flame for maximum flame impingement on ignitor/sensor</li><li>2. Have vent system inspected, including termination cap. Remove any restriction or obstruction</li></ol>
Fireplace produces a clicking/ ticking noise just after burner is lit or shut off	<ol style="list-style-type: none"><li>1. Metal expanding while heating or contracting while cooling</li></ol>	<ol style="list-style-type: none"><li>1. This is normal with most fireplaces. If noise is excessive, contact qualified service person</li></ol>
Slight smoke or odor during initial operation	<ol style="list-style-type: none"><li>1. Residues from manufacturing processes</li></ol>	<ol style="list-style-type: none"><li>1. Problem will stop after a few hours of operation</li></ol>

# TROUBLESHOOTING

Continued



**WARNING: If you smell gas**

- Shut off gas supply.
- Do not try to light any appliance.
- Do not touch any electrical switch; do not use any phone in your building.
- Immediately call your gas supplier from a neighbor's phone. Follow the gas supplier's instructions.
- If you cannot reach your gas supplier, call the fire department.

OBSERVED PROBLEM	POSSIBLE CAUSE	REMEDY
Gas odor even when gas control valve is off	<ol style="list-style-type: none"><li>1. Gas leak. <b>See Warning statement at top of page</b></li><li>2. Control valve defective</li></ol>	<ol style="list-style-type: none"><li>1. Locate and correct all leaks (see <i>Checking Gas Connections</i>, page 21)</li><li>2. Replace control valve</li></ol>
Gas odor during combustion	<ol style="list-style-type: none"><li>1. Foreign matter between control valve and burner</li><li>2. Gas leak. <b>See Warning statement at top of page</b></li></ol>	<ol style="list-style-type: none"><li>1. Take apart gas tubing and remove foreign matter</li><li>2. Locate and correct all leaks (see <i>Checking Gas Connections</i>, page 21)</li></ol>
Glass soots	<ol style="list-style-type: none"><li>1. Debris around burner air mixer</li><li>2. Improper vent configuration</li></ol>	<ol style="list-style-type: none"><li>1. Inspect opening at base of burner to see that it is NOT packed with any type of material</li><li>2. Check vent configuration specification (see <i>Venting Installation</i>, page 11)</li></ol>
Dark residue on inside of fireplace	<ol style="list-style-type: none"><li>1. Air holes at burner inlet blocked</li><li>2. Burner flame holes blocked</li><li>3. Improper venting or excessive blockage</li></ol>	<ol style="list-style-type: none"><li>1. Clean out air holes at burner inlets. Periodically repeat as needed</li><li>2. Remove blockage</li><li>3. Have vent system inspected, including termination cap. Remove any restrictions or obstruction</li></ol>

# WIRING DIAGRAM

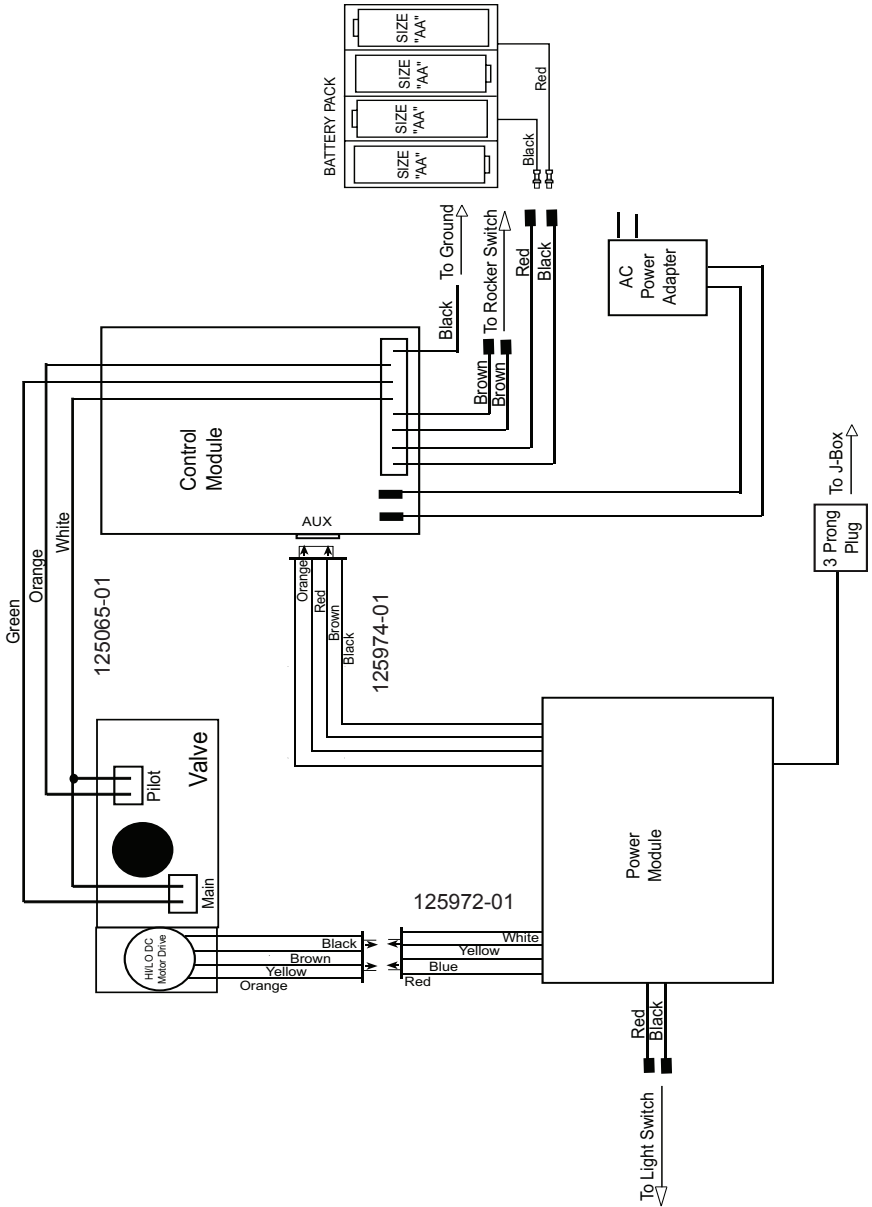

# PARTS

MODELS (V)LDV43NE & (V)LDV43PE

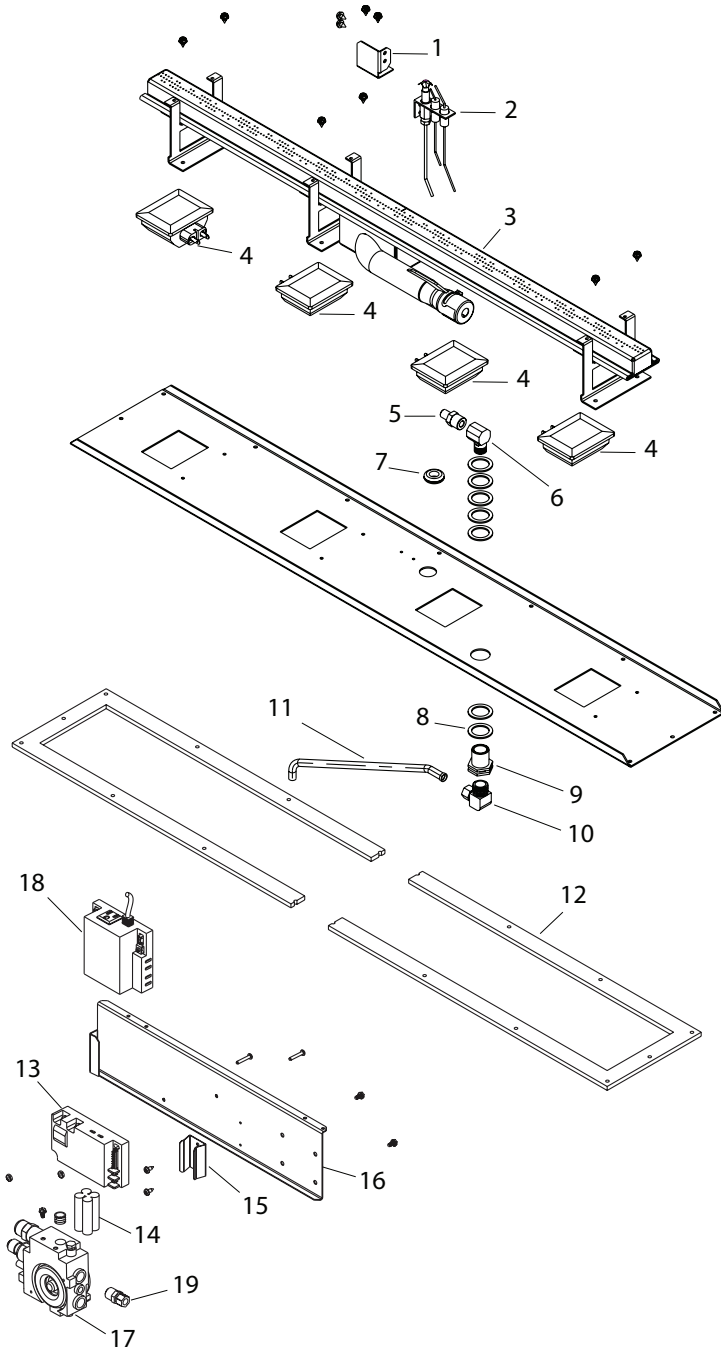

## PARTS

This list contains replaceable parts used in your fireplace. When ordering parts, follow the instructions listed under Replacement Parts on page 42 of this manual.

KEY NO.	PART NO.	DESCRIPTION	(V)LDV43NE	(V)LDV43PE	QTY.
1	125609-02	Pilot Bracket	•	•	1
2	125699-01	Pilot, NG	•		1
	125699-02	Pilot, LP		•	1
3	125752-01	Burner Assembly	•	•	1
4	125961-02	Light Assembly w/ Wire Harness	•	•	1
	126130-02	Light Bulb, G9 120V/20W	•	•	4
5	25599	Orifice, #31	•		1
	23106	Orifice, #49		•	1
6	14296	Brass Elbow	•	•	1
7	114027-01	Grommet	•	•	1
8	116573-01	Flat Washer	•	•	7
9	11214	Bulkhead Fitting	•	•	1
10	14399	Brass Elbow	•	•	1
11	111817-09	Flextube	•	•	1
12	125932-01	Burner Gasket	•	•	2
13	125064-02	Power Module	•	•	1
14	125068-01	Battery Backup	•	•	1
15	125072-02	Battery Backup Bracket	•	•	1
16	125760-01	Valve Bracket	•	•	1
17	125970-01	Valve, NG	•		1
	125970-02	Valve, LP		•	1
18	125973-01	Light Module	•	•	1
19	14396	Connector 3/8 Tube x 3/8 MPT	•	•	1
<b>PARTS AVAILABLE NOT SHOWN</b>					
	26839	Rockwool	•	•	1
	125972-01	Wire Harness (See Page 35)	•	•	1
	125974-01	Wire Harness (See Page 35)	•	•	1
	125971-01	Remote Control	•	•	1
	14253	30" Flex Line	•	•	1
	125065-01	Wire Harness (See Page 35)	•	•	1
	125066-01	AC Adapter (Power Cord)	•	•	1
	125999-01	Clear Pebbles (6 lbs)	•	•	1
	125962-01	Latch Opener	•	•	1

# PARTS

MODELS (V)LDV43NE & (V)LDV43PE

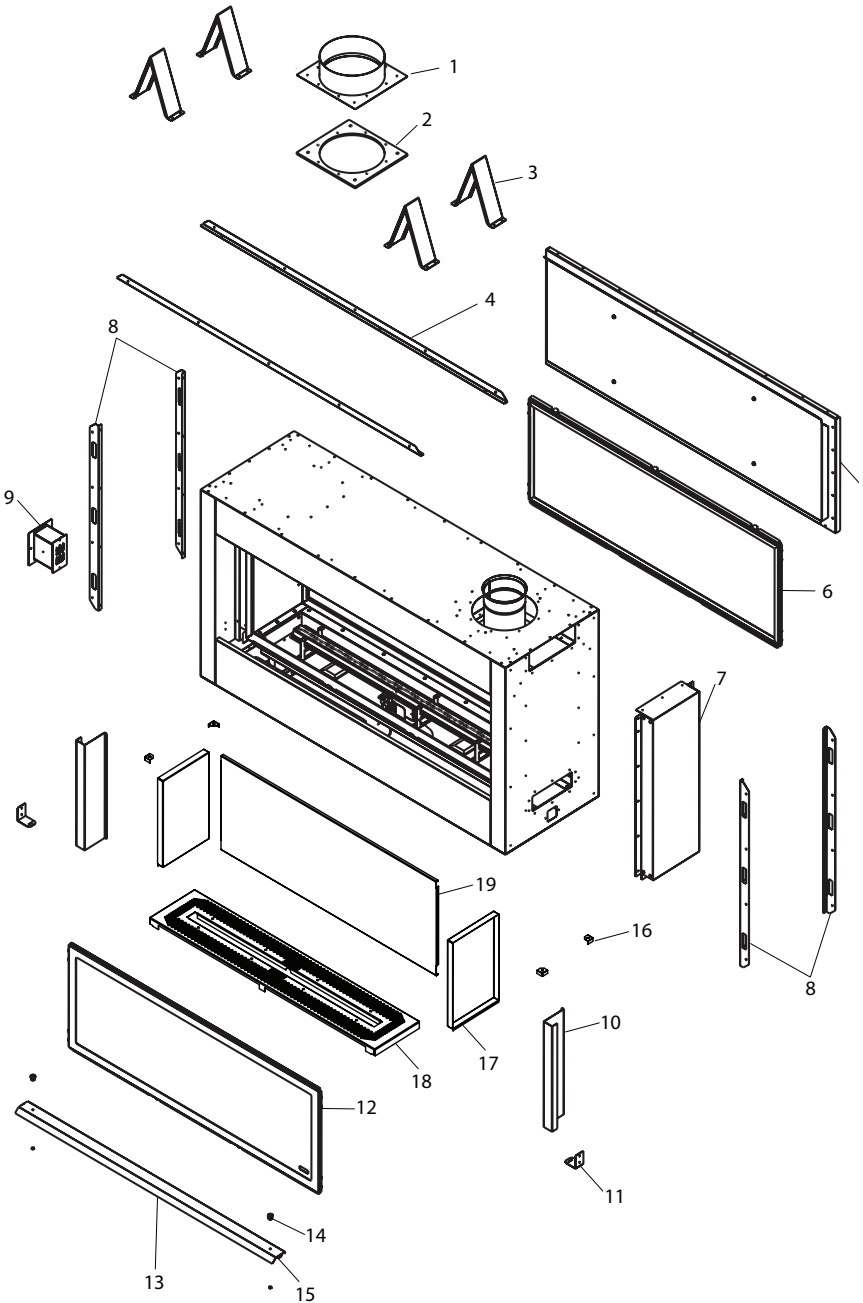



## PARTS

### BURNER ASSEMBLY

This list contains replaceable parts used in your fireplace. When ordering parts, follow the instructions listed under Replacement Parts on page 42 of this manual.

KEY			(V)LDV43NE	(V)LDV43PE	QTY.
NO.	PART NO.	DESCRIPTION			
1	111555-01	8" Outer Connector	•	•	1
2	106702-03	Gasket	•	•	1
3	125847-01	Top Spacer	•	•	4
4	125757-02	Top Nailing Flange	•	•	2
5	125805-01	Rear Panel	•	•	1
6	125741-02	False Door Assembly	•	•	1
7	125729-01	Side Plenum Assembly	•	•	1
8	125757-01	Side Nailing Flange	•	•	4
9	110037-01	Electric Duct Assembly	•	•	1
10	125766-01	Side Face Filler	•	•	2
11	125767-01	Access Cover Retaining Bracket	•	•	2
12	125741-01	Ceramic Door Assembly	•	•	1
13	125879-01	Access Door Assembly	•	•	1
14	17318	Knob	•	•	2
15	11110	Screw, #8-31 X 1/4 PPH	•	•	2
16	125763-01	Corner Bracket	•	•	4
17	125813-01	Side Walls	•	•	2
18	125753-01	Pebble Pan	•	•	1
19	125814-01	Rear Wall	•	•	1

## ACCESSORIES

Purchase these accessories from your local dealer. If they can not supply these accessories call FMI PRODUCTS, LLC at 1-866-328-4537 for information. You can also write to the address listed on the back page of this manual.

### SEE-THRU DOOR KIT

LDSTI

### OUTDOOR DOOR KIT

LDSTO

### SMOOTH GLASS PEBBLES (6 LBS)

GP43SO - Speckled Orange

GP43A - Amber

GP43G - Green

GP43B - Blue

### DECORATIVE FACE TRIM

DFT43B - Black

DFT43AS - Aged Silver

DFT43AC - Aged Cooper

## SPECIFICATIONS

### LDV43NE, VLDV43NE

- Rating: 41,000/26,000 Btu/hr
- Gas Type: Natural Gas Only
- Ignition: Electronic
- Manifold Pressure: 3.5" w.c.
- Minimum Inlet Supply Pressure: 5" w.c.
- Maximum Inlet Supply Pressure: 10.5" w.c.
- Orifice: #31

### LDV43PE, VLDV43PE

- Rating: 39,000/25,000 Btu/hr
- Gas Type: Propane/LP Gas Only
- Ignition: Electronic
- Manifold Pressure: 10" w.c.
- Minimum Inlet Supply Pressure: 11" w.c.
- Maximum Inlet Supply Pressure: 13" w.c.
- Orifice: #49

## REPLACEMENT PARTS

*Note: Use only original replacement parts. This will protect your warranty coverage for parts replaced under warranty.*

Contact authorized dealers of this product. If they can't supply original replacement part(s), call FMI PRODUCTS, LLC at 1-866-328-4537.

When calling, have ready:

- your name
- your address
- model and serial numbers of your heater
- how heater was malfunctioning
- purchase date

Usually, we will ask you to return the part to the factory.

## TECHNICAL SERVICE

You may have further questions about installation, operation, or troubleshooting. If so, contact FMI PRODUCTS, LLC at 1-866-328-4537. When calling please have your model and serial numbers of your heater ready.

You can also visit our web site at [www.fmiproducts.com](http://www.fmiproducts.com).

## SERVICE HINTS

### When Gas Pressure Is Too Low

- pilot will not stay lit
- burners will have delayed ignition
- fireplace will not produce specified heat
- propane/LP gas supply might be low (propane/LP units only)

You may feel your gas pressure is too low. If so, contact your local gas supplier.



---

---

# WARRANTY

## KEEP THIS WARRANTY

Model (located on product or identification tag) \_\_\_\_\_

Serial No. (located on product or identification tag) \_\_\_\_\_

Date Purchased \_\_\_\_\_

Keep receipt for warranty verification.

## FMI PRODUCTS, LLC LIMITED WARRANTIES

### New Products

**Standard Warranty:** FMI PRODUCTS, LLC warrants this new product and any parts thereof to be free from defects in material and workmanship for a period of four (4) years from the date of first purchase from an authorized dealer provided the product has been installed, maintained and operated in accordance with FMI PRODUCTS, LLC's warnings and instructions.

For products purchased for commercial, industrial or rental usage, this warranty is limited to 90 days from the date of first purchase.

### Factory Reconditioned Products

**Limited Warranty:** FMI PRODUCTS, LLC warrants factory reconditioned products and any parts thereof to be free from defects in material and workmanship for 30 days from the date of first purchase from an authorized dealer provided the product has been installed, maintained and operated in accordance with FMI PRODUCTS, LLC's warnings and instructions.

### Terms Common to All Warranties

The following terms apply to all of the above warranties:

Always specify model number and serial number when contacting the manufacturer. To make a claim under this warranty the bill of sale or other proof of purchase must be presented.

This warranty is extended only to the original retail purchaser when purchased from an authorized dealer, and only when installed by a qualified installer in accordance with all local codes and instructions furnished with this product.

This warranty covers the cost of part(s) required to restore this product to proper operating condition and an allowance for labor when provided by a FMI PRODUCTS, LLC Authorized Service Center or a provider approved by FMI PRODUCTS, LLC. Warranty parts must be obtained through authorized dealers of this product and/or FMI PRODUCTS, LLC who will provide original factory replacement parts. Failure to use original factory replacement parts voids this warranty.

Travel, handling, transportation, diagnostic, material, labor and incidental costs associated with warranty repairs, unless expressly covered by this warranty, are not reimbursable under this warranty and are the responsibility of the owner.

Excluded from this warranty are products or parts that fail or become damaged due to misuse, accidents, improper installation, lack of proper maintenance, tampering, or alteration(s).

This is FMI PRODUCTS, LLC's exclusive warranty, and to the full extent allowed by law; this express warranty excludes any and all other warranties, express or implied, written or verbal and limits the duration of any and all implied warranties, including warranties of merchantability and fitness for a particular purpose to four (4) years on new products and 30 days on factory reconditioned products from the date of first purchase. FMI PRODUCTS, LLC makes no other warranties regarding this product.

FMI PRODUCTS, LLC's liability is limited to the purchase price of the product, and FMI PRODUCTS, LLC shall not be liable for any other damages whatsoever under any circumstances including indirect, incidental, or consequential damages.

Some states do not allow limitations on how long an implied warranty lasts or the exclusion or limitation of incidental or consequential damages, so the above limitation or exclusion may not apply to you.

This warranty gives you specific legal rights, and you may also have other rights which vary from state to state.

For information about this warranty contact:

  
**FMI PRODUCTS, LLC**  
2701 S. Harbor Blvd.  
Santa Ana, CA 92704  
1-866-328-4537  
[www.fmiproducts.com](http://www.fmiproducts.com)

125898-01  
Rev. D  
08/12