

Vantage HearthTM

by FMI PRODUCTS, LLC

UNVENTED (VENT-FREE) GAS LOG HEATER OWNER'S OPERATION AND INSTALLATION MANUAL

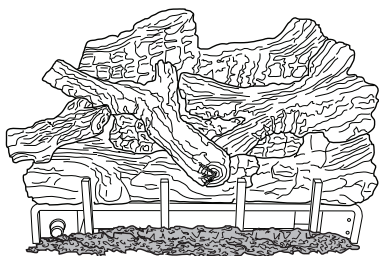

REMOTE BURNER SYSTEM MODELS BGE18NE, BGE18PE, BGE2436NE AND BGE2436PE

FOR USE WITH THE FOLLOWING LOGS
LBG18-RM, LBG24-RM, LBG30-RM,
LBG18-SM, LBG24-SM, LBG30-SM,
LBG36-SM,
LBG18-CM, LBG24-CM, LBG30-CM,
LBG18-BM, LBG24-BM AND LBG30-BM

⚠ WARNING: If the information in this manual is not followed exactly, a fire or explosion may result causing property damage, personal injury or loss of life.

- Do not store or use gasoline or other flammable vapors and liquids in the vicinity of this or any other appliance.
- **WHAT TO DO IF YOU SMELL GAS**
 - Do not try to light any appliance.
 - Do not touch any electrical switch; do not use any phone in your building.
 - Immediately call your gas supplier from a neighbor's phone. Follow the gas supplier's instructions.
 - If you cannot reach your gas supplier, call the fire department.
- Installation and service must be performed by a qualified installer, service agency or the gas supplier.

INSTALLER: Leave this manual with the appliance.
CONSUMER: Retain this manual for future reference.

For more information, visit www.fmiproducts.com

TABLE OF CONTENTS

Safety	2	Wiring Diagram.....	36
Unpacking.....	5	Specifications	36
Product Identification.....	5	Troubleshooting.....	37
Local Codes.....	5	Parts	44
Product Features.....	6	Service Hints	51
Air For Combustion and Ventilation.....	6	Technical Service.....	51
Installation	9	Replacement Parts.....	51
Operation.....	28	Accessories	51
Inspecting Burners.....	33	Warranty.....	Back Cover
Cleaning and Maintenance.....	34		

SAFETY

⚠ WARNING: Improper installation, adjustment, alteration, service or maintenance can cause injury or property damage. Refer to this manual for correct installation and operational procedures. For assistance or additional information consult a qualified installer, service agency or the gas supplier.

⚠ WARNING: This appliance is for installation only in a solid-fuel burning masonry or UL127 factory-built fireplace or in a listed ventless firebox enclosure. It is design-certified for these installations in accordance with ANSI Z21.11.2. Exception: Do not install this appliance in a factory-built fireplace that includes instructions stating it has not been tested or should not be used with unvented gas logs.

⚠ WARNING: This is an unvented gas-fired heater. It uses air (oxygen) from the room in which it is installed. Provisions for adequate combustion and ventilation air must be provided. Refer to *Air for Combustion and Ventilation* section on page 6 of this manual.

This appliance may be installed in an aftermarket,* permanently located, manufactured (mobile) home, where not prohibited by local codes.

This appliance is only for use with the type of gas indicated on the rating plate. This appliance is not convertible for use with other gases.

* Aftermarket: Completion of sale, not for purpose of resale, from the manufacturer

SAFETY

Continued

⚠ WARNING: This product contains and/or generates chemicals known to the state of California to cause cancer or birth defects or other reproductive harm.

IMPORTANT: Read this owner's manual carefully and completely before trying to assemble, operate or service this fireplace. Improper use of this fireplace can cause serious injury or death from burns, fire, explosion, electrical shock and carbon monoxide poisoning.

⚠ DANGER: Carbon monoxide poisoning may lead to death!

Carbon Monoxide Poisoning: Early signs of carbon monoxide poisoning resemble the flu, with headaches, dizziness or nausea. If you have these signs, the fireplace may not be working properly. **Get fresh air at once!** Have fireplace serviced. Some people are more affected by carbon monoxide than others. These include pregnant women, people with heart or lung disease or anemia, those under the influence of alcohol and those at high altitudes.

Natural and Propane/LP gases are odorless. An odor-making agent is added to these gases. The odor helps you detect a gas leak. However, the odor added to the gas can fade. Gas may be present even though no odor exists.

Make certain you read and understand all warnings. Keep this manual for reference. It is your guide to safe and proper operation of this fireplace.

⚠ WARNING: Any change to this heater or its controls can be dangerous.

⚠ WARNING: Do not use a blower insert, heat exchanger insert or other accessory not approved for use with this heater.

⚠ WARNING: Do not allow fans to blow directly into the fireplace. Avoid any drafts that alter burner flame patterns. Ceiling fans can create drafts that alter burner flame patterns. Altered burner patterns can cause sooting.

Due to high temperatures, the appliance should be located out of traffic and away from furniture and draperies.

Do not place clothing or other flammable material on or near the appliance. Never place any objects on the heater.

Heater base assembly becomes very hot when running heater. Keep children and adults away from hot surface to avoid burns or clothing ignition. Heater will remain hot for a time after shutdown. Allow surface to cool before touching.

Carefully supervise young children when they are in the room with heater.

You must operate this heater with the fireplace screen.

Keep the appliance area clear and free from combustible materials, gasoline and other flammable vapors and liquids.

SAFETY

Continued

1. This appliance is only for use with the type of gas indicated on the rating plate. This appliance is not convertible for use with other gases.
2. Do not place propane/LP supply tank(s) inside any structure. Locate propane/LP supply tank(s) outdoors (propane/LP units only).
3. If you smell gas
 - shut off gas supply
 - do not try to light any appliance
 - do not touch any electrical switch; do not use any phone in your building
 - immediately call your gas supplier from a neighbor's phone. Follow the gas supplier's instructions
 - if you cannot reach your gas supplier, call the fire department
4. This heater shall not be installed in a bedroom or bathroom.
5. Before installing in a solid fuel burning fireplace, the chimney flue and firebox must be cleaned of soot, creosote, ashes and loose paint by a qualified chimney cleaner. Creosote will ignite if highly heated. A dirty chimney flue may create and distribute soot within the house. Inspect chimney flue for damage. If damaged, repair flue and firebox before operating heater.
6. Do not burn solid-fuel in a masonry or UL127 factory-built fireplace in which a vent-free room heater is installed.
7. If fireplace has glass doors, never operate this heater with glass doors closed. If you operate heater with doors closed, heat buildup inside fireplace will cause glass to burst. Make sure there are no obstructions across openings of fireplace.
8. To prevent the creation of soot, follow the instructions in *Cleaning and Maintenance*, page 34.
9. Before using furniture polish, wax, carpet cleaner or similar products, turn heater off. If heated, the vapors from these products may create a white powder residue within burner box or on adjacent walls and furniture.
10. This heater needs fresh, outside air ventilation to run properly. This heater has an Oxygen Depletion Sensing (ODS) safety shutoff system. The ODS shuts down the heater if enough fresh air is not available. See *Air for Combustion and Ventilation*, page 6. If heater keeps shutting off, see *Troubleshooting*, page 37.
11. Do not run heater
 - where flammable liquids or vapors are used or stored
 - under dusty conditions
12. Do not use this heater to cook food or burn paper or other objects.
13. Do not use heater if any part has been exposed to or under water. Immediately call a qualified service technician to inspect the room heater and to replace any part of the control system and any gas control which has been under water.
14. Do not operate heater if any log is broken. Do not operate heater if a log is chipped (dime-sized or larger).
15. Turn heater off and let cool before servicing, installing or repairing. Only a qualified service person should install, service or repair heater.
16. Make sure the remote is set to the OFF position when you are away from home for long periods of time.
17. Remote heaters must not be connected to any external electrical source.
18. Operating heater above elevations of 4,500 feet may cause pilot outage.
19. To prevent performance problems, do not use propane/LP fuel tank of less than 100 lb. capacity (propane/LP units only).
20. Provide adequate clearances around air openings.

UNPACKING

⚠ CAUTION: Do not remove the data plates from the grate assembly. The data plates contain important warranty and safety information.

1. Remove logs and heater base assembly from cartons.

Note: Do not pick up heater base assembly by burners. This could damage heater. Always handle base assembly by grate.

2. Remove all protective packaging applied to logs and heater for shipment.
3. Check heater for any shipping damage. If heater is damaged call FMI PRODUCTS, LLC at 1-866-328-4537 for replacement parts before returning to dealer.

PRODUCT IDENTIFICATION

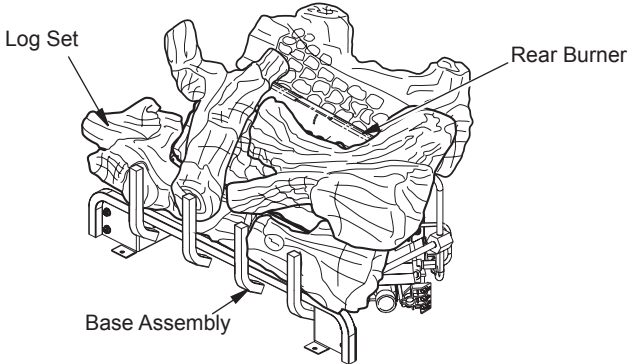

Figure 1 - Product Identification

LOCAL CODES

Install and use heater with care. Follow all local codes. In the absence of local codes, use the latest edition of *The National Fuel Gas Code, ANSI Z223.1/NFPA 54**.

*Available from:

American National Standards Institute, Inc.
1430 Broadway
New York, NY 10018

National Fire Protection Association, Inc.
Batterymarch Park
Quincy, MA 02269

State of Massachusetts: The installation must be made by a licensed plumber or gas fitter in the Commonwealth of Massachusetts.

Sellers of unvented propane or natural gas-fired supplemental room heaters shall provide to each purchaser a copy of 527 CMR 30 upon sale of the unit.

Vent-free gas products are prohibited for bedroom and bathroom installation in the Commonwealth of Massachusetts.

PRODUCT FEATURES

OPERATION

This heater is clean burning. It requires no outside venting. There is no heat loss out a vent or up a chimney. Heat is generated by both realistic flames and glowing coals. This heater is designed for vent-free operation with flue damper closed. It has been tested and approved to ANSI Z21.11.2 standard for unvented heaters. State and local codes in some areas prohibit the use of vent-free heaters.

SAFETY DEVICE

This heater has a pilot with an Oxygen Depletion Sensing (ODS) safety shutoff system. The ODS/pilot is a required feature for vent-free room heaters. The ODS/pilot shuts off the heater if there is not enough fresh air.

ELECTRONIC IGNITION SYSTEM

This heater has an electronic ignitor to light heater fuel supply.

AIR FOR COMBUSTION AND VENTILATION

⚠ WARNING: This heater shall not be installed in a room or space unless the required volume of indoor combustion air is provided by the method described in the *National Fuel Gas Code, ANSI Z223.1/NFPA 54, the International Fuel Gas Code, or applicable local codes. Read the following instructions to insure proper fresh air for this and other fuel-burning appliances in your home.*

Today's homes are built more energy efficient than ever. New materials, increased insulation and new construction methods help reduce heat loss in homes. Home owners weather strip and caulk around windows and doors to keep the cold air out and the warm air in. During heating months, home owners want their homes as airtight as possible.

While it is good to make your home energy efficient, your home needs to breathe. Fresh air must enter your home. All fuel-burning appliances need fresh air for proper combustion and ventilation.

Exhaust fans, fireplaces, clothes dryers and fuel burning appliances draw air from the house to operate. You must provide adequate fresh air for these appliances. This will insure proper venting of vented fuel-burning appliances.

PROVIDING ADEQUATE VENTILATION

The following are excerpts from *National Fuel Gas Code, ANSI Z223.1/NFPA 54, Air for Combustion and Ventilation*.

All spaces in homes fall into one of the three following ventilation classifications:

1. Unusually Tight Construction
2. Unconfined Space
3. Confined Space

The information on pages 6 through 8 will help you classify your space and provide adequate ventilation.

Unusually Tight Construction

The air that leaks around doors and windows may provide enough fresh air for combustion and ventilation. However, in buildings of unusually tight construction, you must provide additional fresh air.

Unusually tight construction is defined as construction where:

- a. walls and ceilings exposed to the outside atmosphere have a continuous water vapor retarder with a rating of one perm (6×10^{-11} kg per pa-sec-m²) or less with openings gasketed or sealed and
- b. weather stripping has been added on operable windows and doors and
- c. caulking or sealants are applied to areas such as joints around window and door frames, between sole plates and floors, between wall-ceiling joints, between wall panels, at penetrations for plumbing, electrical and gas lines and at other openings.

AIR FOR COMBUSTION AND VENTILATION

Continued

If your home meets all of the three criteria above, you must provide additional fresh air. See Ventilation Air From Outdoors, page 8.

If your home does not meet all of the three criteria above, proceed to Determining Fresh-Air Flow For Heater Location, below.

Confined and Unconfined Space

The National Fuel Gas Code, ANSI Z223.1/NFPA 54 defines a confined space as a space whose volume is less than 50 cubic feet per 1,000 Btu/hr (4.8 m³ per kw) of the aggregate input rating of all appliances installed in that space and an unconfined space as a space whose volume is not less than 50 cubic feet per 1,000 Btu/hr (4.8 m³ per kw) of the aggregate input rating of all appliances installed in that space. Rooms communicating directly with the space in which the appliances are installed*, through openings not furnished with doors, are considered a part of the unconfined space.

* Adjoining rooms are communicating only if there are doorless passageways or ventilation grills between them.

DETERMINING FRESH-AIR FLOW FOR HEATER LOCATION

Determining if You Have a Confined or Unconfined Space

Use this work sheet to determine if you have a confined or unconfined space.

Space: Includes the room in which you will install fireplace plus any adjoining rooms with doorless passageways or ventilation grills between the rooms.

- Determine the volume of the space (length x width x height).

Length x Width x Height = _____ cu. ft.
(volume of space)

Example: Space size 20 ft. (length) x 16 ft. (width) x 8 ft. (ceiling height) = 2560 cu. ft. (volume of space)

If additional ventilation to adjoining room is supplied with grills or openings, add the volume of these rooms to the total volume of the space.

- Multiply the space volume by 20 to determine the maximum Btu/Hr the space can support.

_____ (volume of space) x 20 = (Maximum Btu/Hr the space can support)

Example: 2560 cu. ft. (volume of space) x 20 = 51,200 (maximum Btu/Hr the space can support)

- Add the Btu/Hr of all fuel burning appliances in the space.

Vent-free fireplace	_____ Btu/Hr
Gas water heater*	_____ Btu/Hr
Gas furnace	_____ Btu/Hr
Vented gas heater	_____ Btu/Hr
Gas fireplace logs	_____ Btu/Hr
Other gas appliances*	+ _____ Btu/Hr
Total	= _____ Btu/Hr

* Do not include direct-vent gas appliances. Direct-vent draws combustion air from the outdoors and vents to the outdoors.

Example:

Gas water heater	_____	40,000	Btu/Hr
Vent-free fireplace	+	33,000	Btu/Hr
Total	=	73,000	Btu/Hr

- Compare the maximum Btu/Hr the space can support with the actual amount of Btu/Hr used.

_____ Btu/Hr (maximum can support)

_____ Btu/Hr (actual amount used)

Example: 51,200 Btu/Hr (maximum the space can support)

73,000 Btu/Hr (actual amount of Btu/Hr used)

The space in the above example is a confined space because the actual Btu/Hr used is more than the maximum Btu/Hr the space can support. You must provide additional fresh air. Your options are as follows:

- Rework worksheet, adding the space of an adjoining room. If the extra space provides an unconfined space, remove door to adjoining room or add ventilation grills between rooms. See Ventilation Air From Inside Building, page 8.
- Vent room directly to the outdoors. See Ventilation Air From Outdoors, page 8.
- Install a lower Btu/Hr fireplace, if lower Btu/Hr size makes room unconfined.

If the actual Btu/Hr used is less than the maximum Btu/Hr the space can support, the space is an unconfined space. You will need no additional fresh air ventilation.

AIR FOR COMBUSTION AND VENTILATION

Continued

⚠️ WARNING: If the area in which the heater may be operated does not meet the required volume for indoor combustion air, combustion and ventilation air shall be provided by one of the methods described in the *National Fuel Gas Code, ANSI Z223.1/NFPA 54*, the *International Fuel Gas Code*, or applicable local codes.

VENTILATION AIR

Ventilation Air From Inside Building

This fresh air would come from an adjoining unconfined space. When ventilating to an adjoining unconfined space, you must provide two permanent openings: one within 12" of the ceiling and one within 12" of the floor on the wall connecting the two spaces (see options 1 and 2, Figure 2). You can also remove door into adjoining room (see option 3, Figure 2). Follow the *National Fuel Gas Code, ANSI Z223.1/NFPA 54, Air for Combustion and Ventilation* for required size of ventilation grills or ducts.

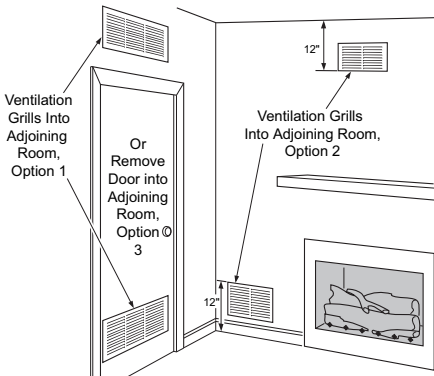

Figure 2 - Ventilation Air from Inside Building

Ventilation Air From Outdoors

Provide extra fresh air by using ventilation grills or ducts. You must provide two permanent openings: one within 12" of the ceiling and one within 12" of the floor. Connect these items directly to the outdoors or spaces open to the outdoors. These spaces include attics and crawl spaces. Follow the *National Fuel Gas Code, ANSI Z223.1/NFPA 54, Air for Combustion and Ventilation* for required size of ventilation grills or ducts.

IMPORTANT: Do not provide openings for inlet or outlet air into attic if attic has a thermostat-controlled power vent. Heated air entering the attic will activate the power vent.

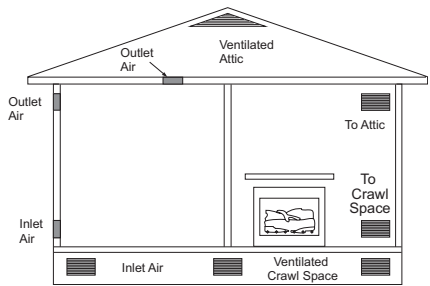

Figure 3 - Ventilation Air from Outdoors

INSTALLATION

NOTICE: This heater is intended for use as supplemental heat. Use this heater along with your primary heating system. Do not install this heater as your primary heat source. If you have a central heating system, you may run system's circulating blower while using heater. This will help circulate the heat throughout the house. In the event of a power outage, you can use this heater as your primary heat source.

WARNING: A qualified service person must install heater. Follow all local codes.

WARNING: Before installing in a solid fuel burning fireplace, the chimney flue and firebox must be cleaned of soot, creosote, ashes and loose paint by a qualified chimney cleaner. Creosote will ignite if highly heated. A dirty chimney flue may create and distribute soot within the house. Inspect chimney and firebox flue for damage. If damaged, repair flue and firebox before operating heater.

WARNING: Seal any fresh air vents or ash clean-out doors located on floor or wall of fireplace. If not, drafting may cause pilot outage or sooting. Use a heat-resistant sealant. Do not seal chimney flue damper.

WARNING: Never install the heater

- in a bedroom or bathroom
- in a recreational vehicle
- where curtains, furniture, clothing or other flammable objects are less than 36" from the front and 42" from top heater, For side clearances see Figure 4 page 10
- in high traffic areas
- in windy or drafty areas

CAUTION: This heater creates warm air currents. These currents move heat to wall surfaces next to heater. Installing heater next to vinyl or cloth wall coverings or operating heater where impurities (such as, but not limited to, tobacco smoke, aromatic candles, cleaning fluids, oil or kerosene lamps, etc.) in the air exist, may discolor walls or cause odors.

IMPORTANT: Vent-free heaters add moisture to the air. Although this is beneficial, installing heater in rooms without enough ventilation air may cause mildew to form from too much moisture. See [*Air for Combustion and Ventilation*](#), page 6.

INSTALLATION

Continued

CHECK GAS TYPE

Use the correct type of gas (natural or propane/LP). If your gas supply is not the correct gas type, do not install heater. Call dealer where you bought heater for proper type heater.

WARNING: This appliance is equipped for either natural gas or propane/LP gas but not both. Gas type is indicated on the rating plate. Field conversion is not permitted.

INSTALLATION AND CLEARANCES FOR VENT-FREE OPERATION

WARNING: Maintain the minimum clearances. If you can, provide greater clearances from floor, ceiling and adjoining wall.

Minimum Fireplace Clearance to Combustible Materials
Side Wall 16", Ceiling 42", Floor 5", Front 36"

LOG SIZING REQUIREMENTS

Log Set Models	Minimum Firebox Size			
	Height	Depth	Front Width	Rear Width*
LBG18-SM	17"	13.5"	20"	14"
LBG18-RM	17"	13.5"	20"	14"
LBG24-SM	17"	13.5"	26"	18"
LBG24-RM	17"	13.5"	26"	18"
LBG30-SM	21"	13.5"	32"	22"
LBG30-RM	21"	13.5"	32"	22"
LBG36-SM	21"	13.5"	38"	27.5"
LBG18-BM	17"	14.5"	26"	20"
LBG18-CM	17"	14.5"	26"	20"
LBG24-BM	17"	14.5"	29"	22"
LBG24-CM	17"	14.5"	29"	22"
LBG30-BM	21"	14.5"	32"	22"
LBG30-CM	21"	14.5"	32"	22"

Carefully follow these instructions. This will ensure safe installation into a masonry, UL127-listed manufactured fireplace or listed vent-free firebox.

Minimum Clearances For Side Combustible Material, Side Wall and Ceiling

A. Clearances from the side of the fireplace cabinet to any combustible material and wall should follow diagram in Figure 4.

Example: The face of a mantel, bookshelf, etc. is made of combustible material and protrudes 3 1/2" from the wall. This combustible material must be 4" from the side of the fireplace cabinet (see Figure 4).

Note: When installing your gas logs into a manufactured firebox, follow firebox manufacturer's instructions for minimum clearances to combustible materials.

B. Clearances from the top of the fireplace opening to the ceiling should not be less than 42".

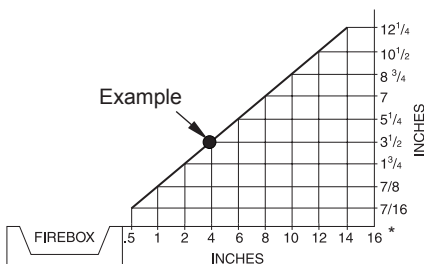

*Minimum 16" from Side Wall

Figure 4 - Minimum Clearance for Combustible to Wall

MINIMUM NONCOMBUSTIBLE MATERIAL CLEARANCES

If Not Using Mantel

Note: If using a mantel proceed to If Using Mantel. If not using a mantel, follow the information on this page.

You must have noncombustible material(s) above the fireplace opening. Noncombustible materials (such as slate, marble, tile, etc.) must be at least 1/2" thick. With sheet metal, you must have noncombustible material behind it. Noncombustible material must extend at least 8" up (for all models). If noncombustible material is less than 12", you must install

INSTALLATION

Continued

the fireplace hood accessory (24", 30" and 36" Models Only). See Figure 5 for minimum clearances.

Noncombustible Material Distance (A)	Requirements for Safe Installation
12" or more	Noncombustible material OK.
Between 8" and 12"	24", 30" or 36" Models: Install fireplace hood accessory (GA6050 or GA6053 see <u>Accessories</u> , page 51). 18" Model: Noncombustible material OK.
Less than 8"	Noncombustible material must be extended to at least 8". See <u>Between 8" and 12"</u> , above. If you cannot extend material, you must operate heater with flue damper open.

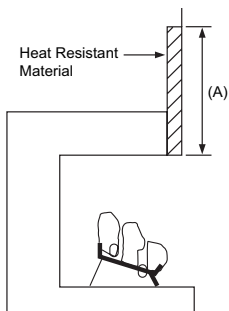

Figure 5 - Heat Resistant Material (Slate, Marble, Tile, etc.) Above Fireplace If Using Mantel

You must have noncombustible material(s) above the fireplace opening. Noncombustible materials (such as slate, marble, tile, etc.) must be at least 1/2" thick. With sheet metal, you must have noncombustible material behind it. Noncombustible material must extend at least 8" up (for all models). If noncombustible material is less than 12", you must install the fireplace hood accessory (24", 30" and 36" Models Only). Even if noncombustible material is more than 12", you may need the hood accessory to deflect heat away from your mantel shelf. See Figures 5 and 6 and Figure 7, page 12, for minimum clearances.

MANTEL CLEARANCES

In addition to meeting noncombustible material clearances, you must also meet required clearances between fireplace opening and mantel shelf. If you do not meet the clearances listed below, you will need a hood.

Determining Minimum Mantel Clearance

If you meet minimum clearance between mantel shelf and top of fireplace opening, a hood is not required (see Figure 6).

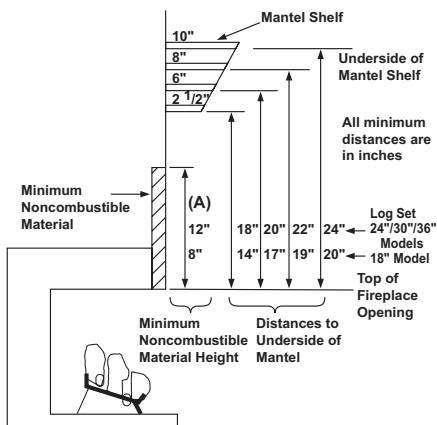

Figure 6 - Minimum Mantel Clearances Without Using Hood

Determining Minimum Mantel Clearance When Using a Hood

If minimum clearances in Figure 6, page 11, are not met, you must have a hood. When using a hood there are still certain minimum mantel clearances required. Follow minimum clearances shown in Figure 7, when using hood.

NOTICE: Surface temperatures of adjacent walls and mantels become hot during operation. Walls and mantels above the firebox may become hot to the touch. If installed properly, these temperatures meet the requirement of the national product standard. Follow all minimum clearances shown in this manual.

INSTALLATION

Continued

NOTICE: If your installation does not meet the minimum clearances shown, you must do one of the following:

- operate the logs only with the flue damper open
- raise the mantel to an acceptable height
- remove the mantel

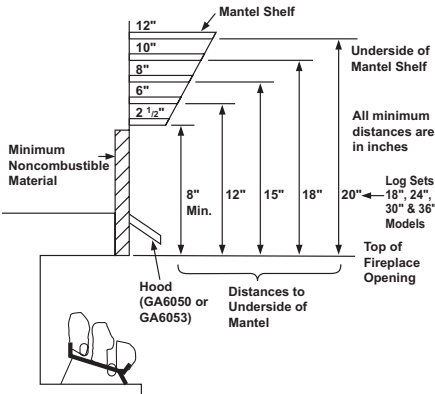

Figure 7 - Minimum Mantel Clearances When Using Hood

FLOOR CLEARANCES

- If installing appliance on the floor level, you must maintain the minimum distance of 14" to combustibles (see Figure 8).
- If combustible materials are less than 14" to the fireplace, you must install appliance at least 5" above the combustible flooring (see Figure 9).

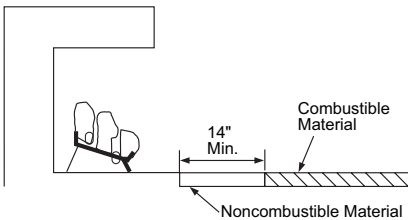

Figure 8 - Minimum Fireplace Clearances If Installed at Floor Level

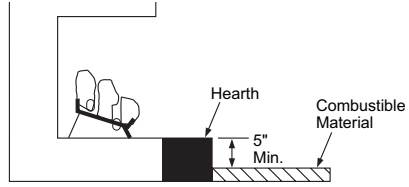

Figure 9 - Minimum Fireplace Clearances Above Combustible Flooring

INSTALLING HEATER BASE ASSEMBLY

WARNING: You must secure this heater to fireplace floor. If not, heater will move when you adjust controls. Moving heater may cause a gas leak.

WARNING: If installing in a sunken fireplace, special care is needed. You must raise the fireplace floor to allow access to heater control panel. This will insure adequate air flow and guard against sooting and controls being damaged. Raise fireplace floor with noncombustible material. Make sure material is secure.

CAUTION: Do not pick up heater base assembly by burners. This could damage heater. Only handle base assembly by grates.

IMPORTANT: Make sure the heater burners are level. If heater is not level, heater will not work properly.

Installation Items Needed

- hardware package (provided with heater)
- approved flexible gas hose and fittings (if allowed by local codes)
- sealant (resistant to propane/LP gas, not provided)
- electric drill with 3/16" masonry drill bit

Note: Install optional Receiver and Hand-Held Remote Control Kit (see [Accessories](#), page 51) before installing gas log heater. See installation instructions included with the kit.

INSTALLATION

Continued

1. Apply pipe joint sealant lightly to male threads of gas fitting (provided). Connect approved flexible gas hose to inlet side of gas control (see Figure 10).
IMPORTANT: Hold gas regulator with wrench when connecting flexible gas hose.
2. Position heater base assembly in fireplace.
3. Mark screw locations through holes in front panel of base (see Figure 11). If installing in a brick-bottom fireplace, mark screw locations in mortar joint of bricks.
4. Remove heater base from fireplace.
5. Drill holes at marked locations using 3/16" drill bit.
6. Attach base, through holes in front panel of base, to fireplace floor using masonry screws provided in hardware package (see Figure 11).
7. Connect to gas supply. See [Connecting To Gas Supply](#).

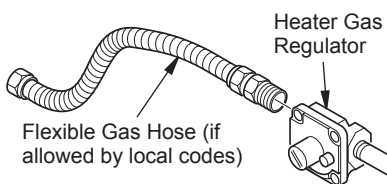

Figure 10 - Attaching Flexible Gas Hose to Heater Gas Regulator

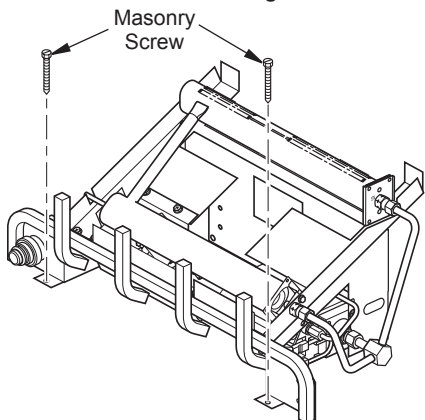

Figure 11 - Attaching Base to Fireplace Floor

CONNECTING TO GAS SUPPLY

⚠ WARNING: This appliance requires a 1/2" NPT (National Pipe Thread) inlet connection to the pressure regulator.

⚠ WARNING: A qualified service person must connect heater to gas supply. Follow all local codes.

⚠ CAUTION: Never connect propane/LP fireplace directly to the propane/LP supply. This heater requires an external regulator (not supplied). Install the external regulator between the heater and propane/LP supply.

⚠ WARNING: Never connect natural gas fireplace to private (non-utility) gas wells. This gas is commonly known as wellhead gas.

Installation Items Needed

Before installing heater, make sure you have the items listed below.

- external regulator (supplied by installer)
- piping (check local codes)
- sealant (resistant to propane/LP gas)
- equipment shutoff valve *
- test gauge connection *
- sediment trap
- tee joint
- pipe wrench
- approved flexible gas line with gas connector (if allowed by local codes)

*An equipment shutoff valve with 1/8" NPT tap is an acceptable alternative to test gauge connection. Purchase the optional equipment shutoff valve from your dealer.

INSTALLATION

Continued

For propane/LP units, the installer must supply an external regulator. The external regulator will reduce incoming gas pressure. You must reduce incoming gas pressure to between 11" and 14" of water. If you do not reduce incoming gas pressure, heater regulator damage could occur. Install external regulator with the vent pointing down as shown in Figure 12. Pointing the vent down protects it from freezing rain or sleet.

⚠ CAUTION: Use only new, black iron or steel pipe. Internally-tinned copper tubing may be used in certain areas. Check your local codes. Use pipe of 1/2" diameter or greater to allow proper gas volume to heater. If pipe is too small, undue loss of volume will occur.

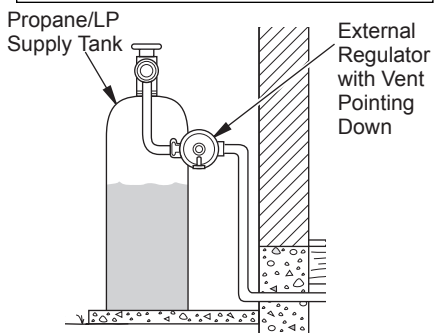

Figure 12 - External Regulator With Vent Pointing Down

Installation must include an equipment shutoff valve, union and plugged 1/8" NPT tap. Locate NPT tap within reach for test gauge hook up. NPT tap must be upstream from heater (see Figure 13).

IMPORTANT: Install equipment shutoff valve in an accessible location. The equipment shutoff valve is for turning on or shutting off the gas to the appliance.

Check your building codes for any special requirements for locating equipment shutoff valve to fireplaces.

Apply pipe joint sealant lightly to male NPT threads. This will prevent excess sealant from going into pipe. Excess sealant in pipe could result in clogged heater valves.

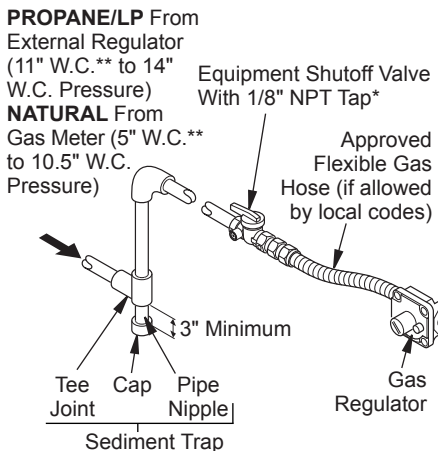

Figure 13 - Gas Connection

* Purchase the optional equipment shutoff valve from your dealer.

**Minimum inlet pressure for purpose of input adjustment.

⚠ WARNING: Use pipe joint sealant that is resistant to liquid petroleum (LP) gas.

We recommend that you install a sediment trap in supply line as shown in Figure 13. Locate sediment trap where it is within reach for cleaning. Install in piping system between fuel supply and heater. Locate sediment trap where trapped matter is not likely to freeze. A sediment trap traps moisture and contaminants. This keeps them from going into heater controls. If sediment trap is not installed or is installed wrong, heater may not run properly.

⚠ CAUTION: Avoid damage to gas control. Hold gas control with wrench when connecting it to gas piping and/or fittings.

INSTALLATION

Continued

CHECKING GAS CONNECTIONS

WARNING: Test all gas piping and connections, internal and external to unit, for leaks after installing or servicing. Correct all leaks at once.

WARNING: Never use an open flame to check for a leak. Apply a noncorrosive leak detection fluid to all joints. Bubbles forming show a leak. Correct all leaks at once.

CAUTION: Make sure external regulator has been installed between propane/LP supply and heater. See guidelines under *Connecting to Gas Supply*, page 13.

PRESSURE TESTING GAS SUPPLY PIPING SYSTEM

Test Pressures In Excess Of 1/2 PSIG (3.5 kPa)

1. Disconnect appliance with its appliance main gas valve (control valve) and equipment shutoff valve from gas supply piping system. Pressures in excess of 1/2 psig will damage heater regulator.
2. Cap off open end of gas pipe where equipment shutoff valve was connected.
3. Pressurize supply piping system by either opening propane/LP supply tank valve for propane/LP gas or opening main gas valve located on or near gas meter for natural gas or using compressed air.
4. Check all joints of gas supply piping system. Apply noncorrosive leak detection fluid to all joints. Bubbles forming show a leak.
5. Correct all leaks at once.
6. Reconnect heater and equipment shutoff valve to gas supply. Check reconnected fittings for leaks.

Test Pressures Equal To or Less Than 1/2 PSIG (3.5 kPa)

1. Close equipment shutoff valve (see Figure 14).
2. Pressurize supply piping system by either opening propane/LP supply tank valve for propane/LP gas or opening main gas valve located on or near gas meter for natural gas or using compressed air.
3. Check all joints from gas meter to equipment shutoff valve for natural gas or propane/LP supply to equipment shutoff valve for propane/LP (see Figure 15 or 16). Apply noncorrosive leak detection fluid to all joints. Bubbles forming show a leak.
4. Correct all leaks at once.

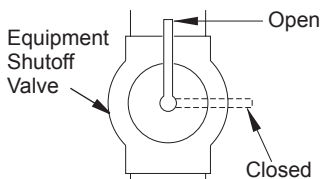

Figure 14 - Equipment Shutoff Valve

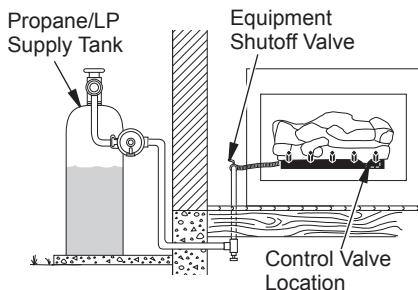

Figure 15 - Checking Gas Joints (Propane/LP Only)

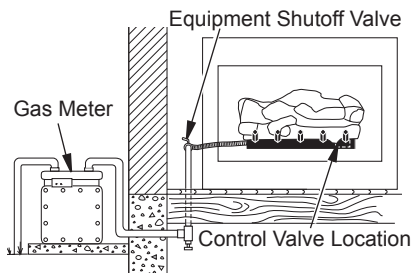

Figure 16 - Checking Gas Joints (Natural Gas Only)

INSTALLATION

Continued

PRESSURE TESTING HEATER GAS CONNECTIONS

1. Open equipment shutoff valve (see Figure 14, page 15).
2. Open main gas valve located on or near gas meter for natural gas or open propane/LP supply tank valve.
3. Make sure control knob of heater is in the OFF position.
4. Check all joints from equipment shutoff valve to gas valve (see Figure 15 or 16, page 15). Apply noncorrosive leak detection fluid to all joints. Bubbles forming show a leak.
5. Correct all leaks at once.
6. Light heater (see *Operation*, page 28 depending on your model). Check all other internal joints for leaks.
7. Turn off heater (see *To Turn Off Gas to Appliance*, page 28, depending on your model).

POWER SUPPLY AND BATTERY INSTALLATION

It is helpful to have a flashlight so you can see the connections as described below. Locate the battery power supply. It is the black box with the red and black wires. Locate the control module (see Figure 17). Connect the battery power supply to the control module by plugging the battery power supply to the mating receptacle on the control module. The receptacle is located on the side of the black control module next to the word "SUPPLY" which is molded in the control module's black housing (see Figure 17). Be certain to push the plug fully into the receptacle. Install batteries in the battery power supply and hand held remote control.

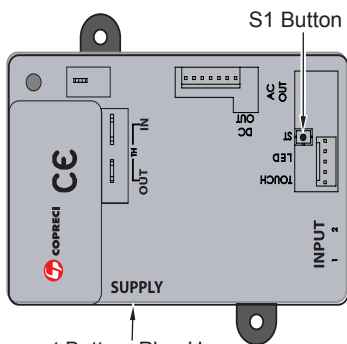

Figure 17 - Control Module

TOUCH PAD INSTALLATION

Locate the touch pad wire harness and the touch pad control (see Figure 18). They are shipped from the factory in the clear plastic bag with your owner's manual. Connect the black plastic connectors together as shown in Figure 19. Connect the remaining end with the white plastic connector to the control module in the socket marked TOUCH LED (see Figure 20).

NOTE: The touch pad includes a red LED display light. If the LED remains on, the black plug is connected upside down. You must unplug the touch pad control from the touch pad wire harness, turn over, and reconnect.

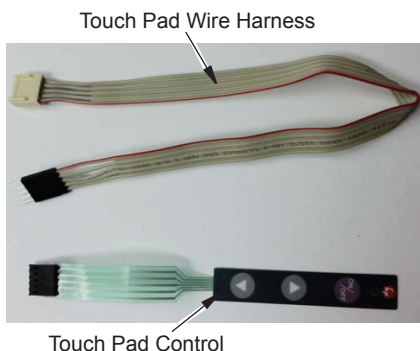

Figure 18 - Touch Pad Wire Harness and Touch Pad Control

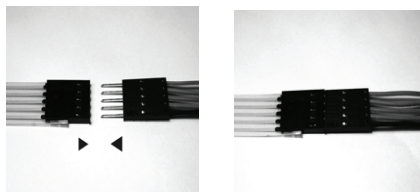

Figure 19 - Touch Pad Control Cable



Figure 20 - Connecting end of Touch Pad Cable

INSTALLATION

Continued

RE-PAIRING

IMPORTANT! This appliance is shipped with the remote control and control module (receiver) paired. However, if more than one Copreci brand electronic ignition system is to be used within a home or showroom, all but one appliance must have the remote control and control module re-paired in order for each appliance to operate on a unique frequency. For multiple appliances, on all but one follow the instructions under *Re-Pairing* on page 17 before moving to *Installing Logs* on page 18. For single appliance installations, skip the RE-PARING section and proceed to *Installing Logs*.

It is helpful to have a flashlight so you can see the connections as described below. Before proceeding, locate the yellow/orange S1 button on the control module. You will need to access this button during the re-pairing procedure and only have 20 seconds to press and release it. A small nail or ink pen will also be useful to press this button (see Figure 17, page 16).

Press and hold the "Off" button  on the remote control for 40 seconds. During this time, the screen will go blank, this is normal. See Figure 21.

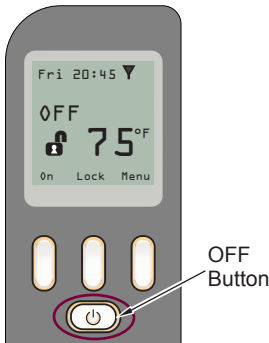

Figure 21 - Main Screen

After 40 seconds, the configuration menu appears (see Figure 22). With "Pairing" highlighted press the middle "select" button. "Off" becomes highlighted (see Figures 22 and 23).

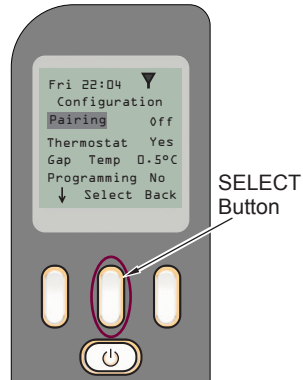

Figure 22 - Configuration Menu

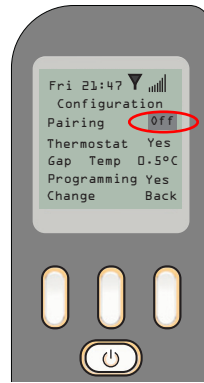

Figure 23 - Off Highlighted

IMPORTANT! Be prepared to press the S1 button as noted in the beginning of this section. After the next step, you have only 20 seconds to push (press and release) the S1 button (yellow/orange) in the control module (see Figure 17).

NOTE: The control module may be turned differently than shown in this figure. Look for the matching text on the control module to help locate the small yellow / orange S1.

INSTALLATION

Continued

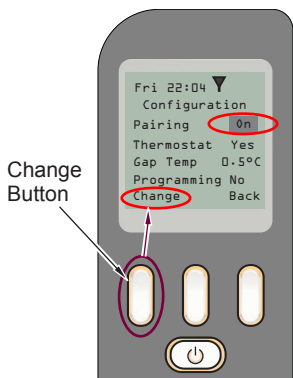

Figure 24 - Change OFF to ON

Press the left "Change" button and "Off" becomes "On" (see Figure 24, above). Press the S1 button to re-pair the remote to the control module. Once this operation is done, you will hear one beep in the control module and the configuration menu will show signal bars: **Full** (see Figure 25). If you do not hear the beep and then see signal bars within 30 seconds of hearing the beep, then the repairing process was not completed successfully. If this occurs, remove the batteries from the remote control, wait 3 minutes, and restart the re-pairing process. If you see signal bars, then the remote control has paired properly. Go to the next step.

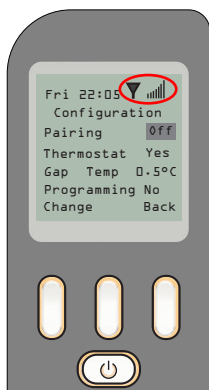

Figure 25 - Signal Bars

Press the "Back" button once to return the highlighted selection to "Pairing". Press the "Middle" button and release. The indication on the "Pairing" will become "Off" (see Figure 26). The re-pairing is over. To return to the main screen, press the "Back" button until you get to the main screen. The main screen is shown in Figure 21, page 17.

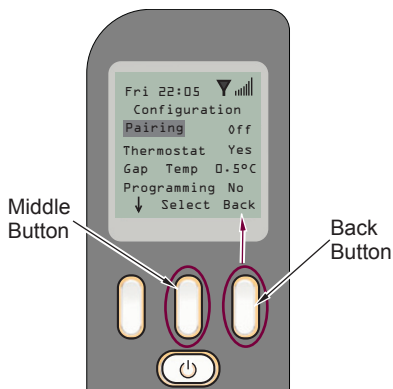

Figure 26 - Back and Middle Buttons

INSTALLING LOGS

WARNING: Failure to position the parts in accordance with these diagrams or failure to use only parts specifically approved with this heater may result in property damage or personal injury.

BG & BGE Series Burner System - Log Compatibility Chart		
Burner System Models	Fiber Log Models	Concrete Log Models
BGE18NE BGE18PE	LBG18-SM LBG18-CM	LBG18-RM LBG18-BM
BGE2436NE BGE2436PE	LBG24-SM LBG30-SM LBG36-SM LBG24-CM LBG30-CM	LBG24-RM LBG30-RM LBG24-BM LBG30-BM

Figure 27 - BG & BGE Series Burner System- Log Compatibility Chart

Log Support Brackets

If installing a LBG36-SM, attach log support brackets before installing logs. These brackets are provided with the BGE2436 series burner systems.

1. Install left bracket to left side of chassis using 2 screws provided (see Figure 28, page 19).
2. Install right bracket to right front of chassis using 2 screws provided (see Figure 28, page 19). This bracket will also be used as remote control bracket if remote is installed.

INSTALLATION

Continued

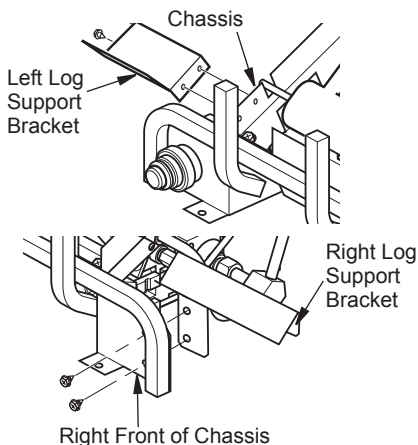

Figure 28 - Installing Log Support Brackets

FIBER LOG MODELS LBG(18,24,30,36)-SM

Note: Your appliance may vary from model shown but log placement will be the same.

1. Place bottom log in center of the base assembly as shown in Figure 29.
2. Rest rear log in back corner sections of base assembly as shown in Figure 29. Make sure log is completely vertical and not leaning in toward burner where flame will touch the log.
3. Position front right log against right side of grate prongs (see Figure 29).
4. Position front left log against left side of grate prongs (see Figure 29).

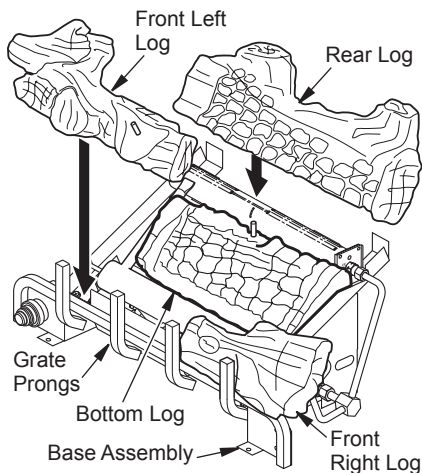

Figure 29 - Installing Log Set

5. Place middle right log over front right and bottom logs as shown in Figure 30. Be sure hole in middle right log seats over pin in bottom log.
6. Place middle left log over front left and bottom logs as show in Figure 30. Be sure hole in middle left log seats over pin in front left log.

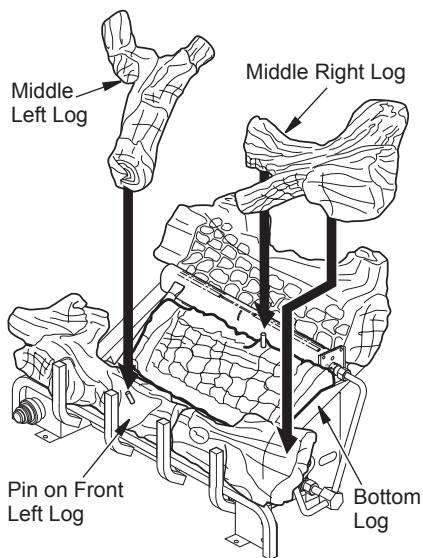

Figure 30 - Installing Log Sets

7. For LTF36-SM, the front right and left logs are longer and are supported with brackets on each end (see Figure 31, page 20). Place left and right small front logs under left bracket and beside right bracket.
8. For LBG36-SM, position left and right control cover logs as shown in Figure 32, page 20. These may be placed as desired to hide controls.

INSTALLATION

Continued

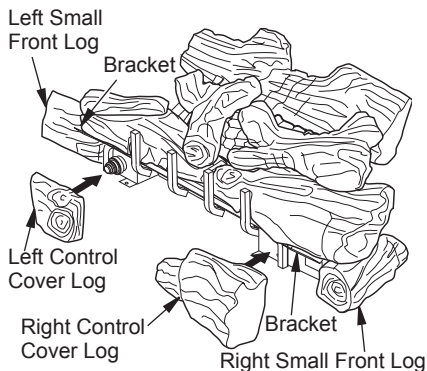

Figure 31 - Installing LBG36-SM Model Control Cover Logs



LBG(18,24,30)-SM MODELS



LBG36-SM MODELS

Figure 32 - Correct Log Placement

CONCRETE LOG MODELS

LBG(18,24,30)-RM

Each log is marked with a number. These numbers will help you identify the log when installing (see chart on page 21). It is very important to install these logs exactly as instructed. Do not modify logs. Only use logs supplied with heater.

Note: Your appliance may vary from model shown but log placement will be the same.

1. Place fiber ramp-log in center on chassis as shown in Figure 33. The fiber ramp-log can be identified by its shape and much lighter weight when compared to the other logs.

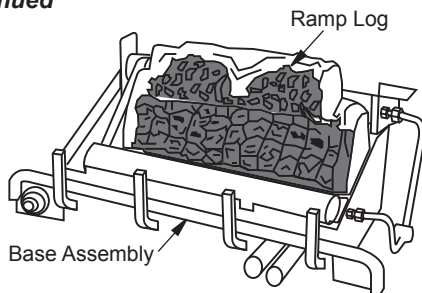

Figure 33 - Installing Log Set

2. The log must sit flat on the black sheet metal and behind the left metal tab as shown in Figure 34.
3. Place front left and right logs and rear log as shown in Figure 35.

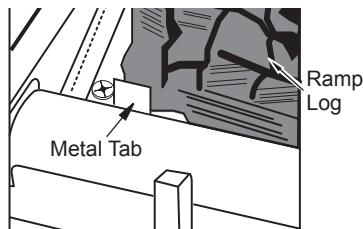

Figure 34 - Installing Log Set

4. Place top left log as shown in Figure 36, page 21. The bottom of the log is shaped to fit onto the recessed areas of the front left log and the rear log. The recessed areas are painted yellow.
5. Place top right log as shown in Figure 36, page 21. The bottom of the log is shaped to fit onto the recessed areas of the front right log and the rear log. The recessed areas are painted yellow.

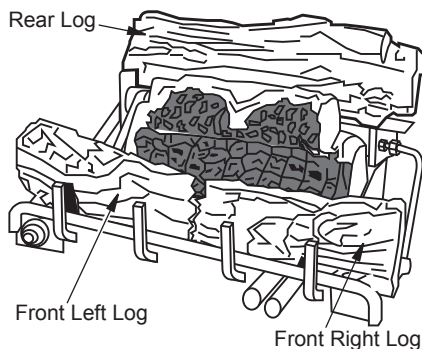

Figure 35 - Installing Logs

INSTALLATION

Continued

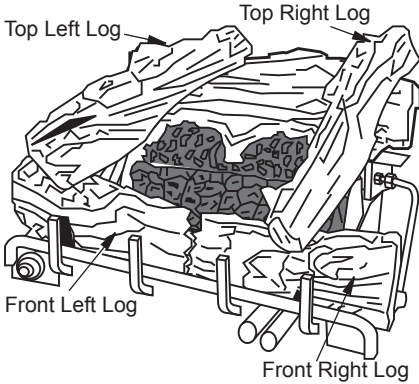

Figure 36 - Installing Logs

- Place the small top right log as shown in Figure 37. The bottom of the log is shaped to fit onto the recessed areas of the top right log and the front right log. The recessed areas are painted yellow.

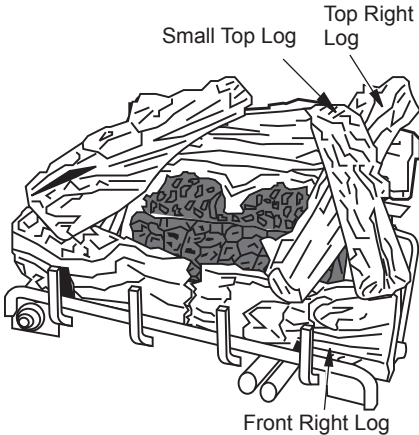

Figure 37 - Installing Log

Description	LBG18-RM	LBG24-RM	LBG30-RM	Qty
Front Left Log	012	001	007	1
Front Right Log	013	002	008	1
Rear Log	014	003	009	1
Top Left Log	016	005	011	1
Top Right Log	015	004	010	1
Small Top Right Log	006	006	006	1

FIBER LOG MODELS LBG(18,24,30)-CM

Note: Your appliance may vary from model shown but log placement will be the same.

- Place rear log in back corner sections of base assembly as shown in Figure 38. The rear log is designed to lean back slightly when installed correctly.

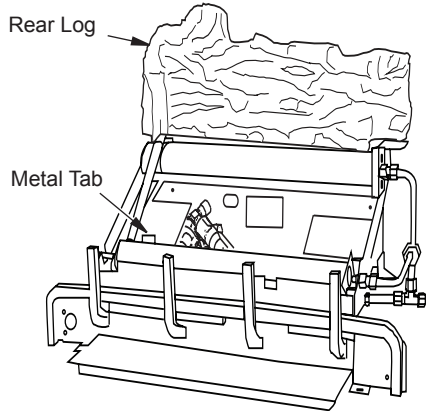

Figure 38 - Installing Rear Log

- Place ramp log in center of base assembly as shown in Figure 39. Make sure the side marked BOTTOM is setting down on the base. The log will sit behind the metal base as shown in Figure 34, page 20.

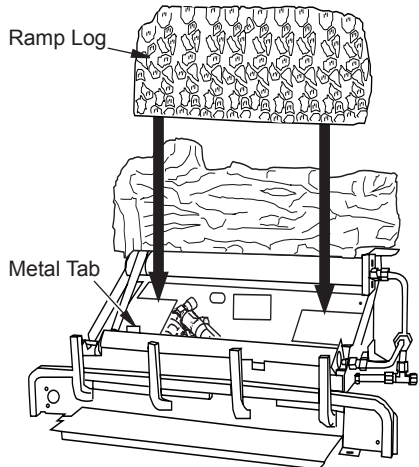

Figure 39 - Installing Ramp Log

INSTALLATION

Continued

3. Position front left log against left side of grate prongs (see Figure 40). The two recessed areas fit behind the two grate prongs.

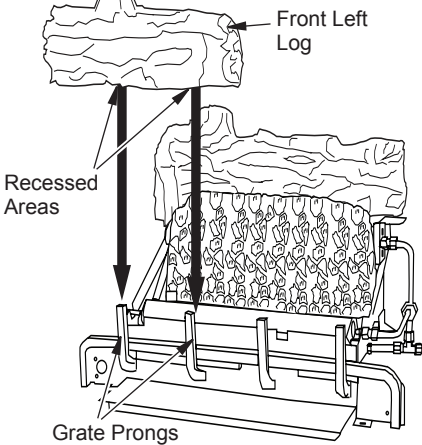

Figure 40 - Installing Front Left Log

4. Position front right log against right side of grate prongs (see Figure 41). The two recessed areas fit behind the two grate prongs.

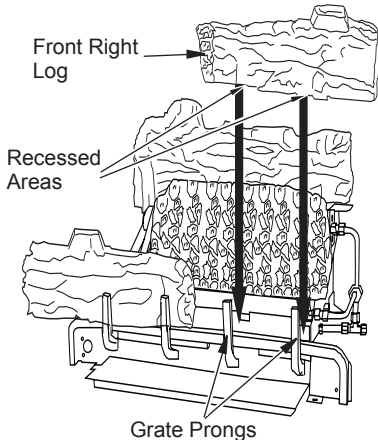

Figure 41 - Installing Front Right Log

5. Place top left front log onto front left log. Match the rectangular projection on top of front left log with the rectangular hole on the bottom of the top left front log. The top left front log will rest on top of the front left log (see Figure 42).

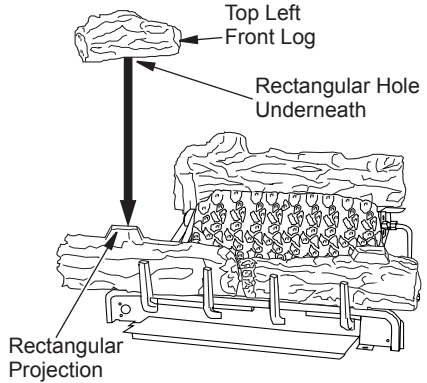

Figure 42 - Installing Top Left Front Log

6. Place top right front log onto front right log. Match the rectangular projection on top of the front right log with the rectangular hole on the bottom of the top right front log as shown in Figure 43. The top right front log will rest on top of the front right log.

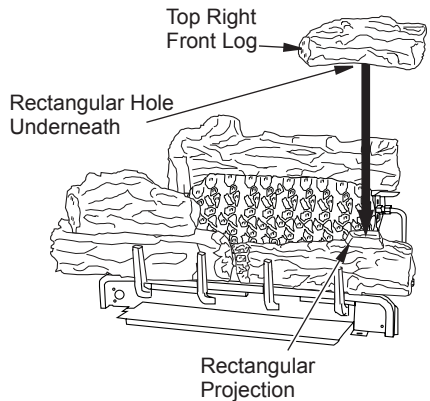

Figure 43 - Installing Top Right Front Log

INSTALLATION

Continued

- Place the middle log onto the ramp log as shown in Figure 44. The middle log has two tabs on the bottom to position from left to right on the ramp log. The front of the middle log should be touching the top left front log and top right front logs.

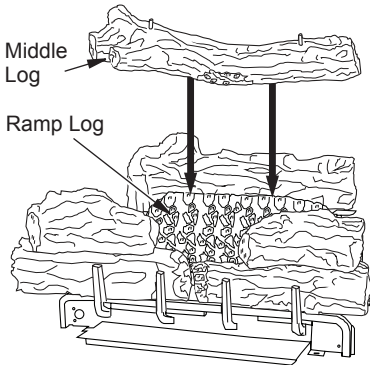

Figure 44 - Installing Middle Log

- Place the left and right ember logs as shown in Figure 46. Do not place the logs where they will be touched by flame. They are intended to cover the sheet metal on the front left and right sides of the base assembly.

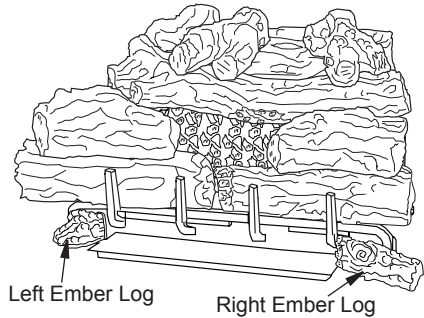

Figure 46 - Installing Ember Logs

- Place the rear left top log on top of the middle log and the rear log. Match the pin on the middle log with the round hole in the bottom of the rear left top log (see Figure 45). The rear log has a flat area for the back of the rear left top log to set in.
- Place the rear right top log on top of the middle log and the rear log. Match the pin on the middle log with the round hole in the bottom of the rear right top log (see Figure 45). The rear log has a flat area for the back of the rear right top log to set in.

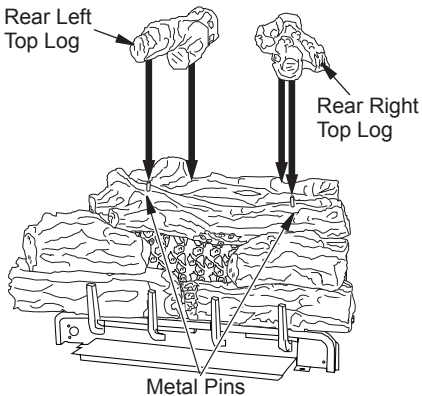

Figure 45 - Installing Rear Left Top Log and Rear Right Top Log

INSTALLATION

Continued

CONCRETE LOG MODELS

LBG(18,24,30)-BM

Note: Your appliance may vary from model shown but log placement will be the same.

1. Before placing any logs on the chassis you will need to remove the Air Shield located on the left side near the rear burner as shown in Figure 47. The Air Shield is held in place with one screw, remove the Air Shield and place the screw back into the hole in the chassis. Place the Air Shield with you owner's manual and keep

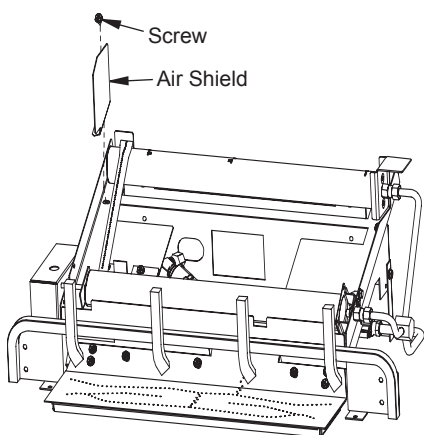

Figure 47 - Removing Air Shield

2. Place fiber ramp log in center of chassis as shown in Figure 48. The fiber ramp log can be identified by the shape and much lighter weight when compared to the other logs. The log must sit flat on the black sheet metal and behind the left metal tab as shown. Make sure the side marked "BOTTOM" is setting down.

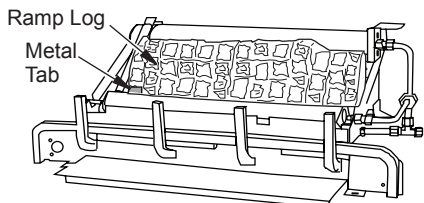

Figure 48 - Installing Fiber Ramp Log

3. Place front left and front right logs as shown in Figure 49.

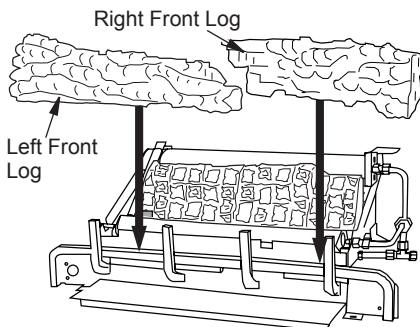

Figure 49 - Installing Left/Right Front Logs

4. Place left ember bed log as shown in Figure 50. The log has groove on one side that sets on the ember bed pan. The back side of this log needs to rest against the front of the base assembly. Make sure the flame from the ember pan does not touch the ember bed log.

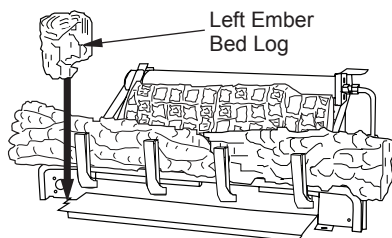

Figure 50 - Installing Left Ember Bed Log

5. The right ember bed log has a hole in the bottom that sets on the grate finger and the other end rest on the fireplace floor, place log as shown in Figure 51, page 25. The back side of this log needs to rest against the front of the base assembly, make sure the flame from the ember pan does not touch the ember bed log.

INSTALLATION

Continued

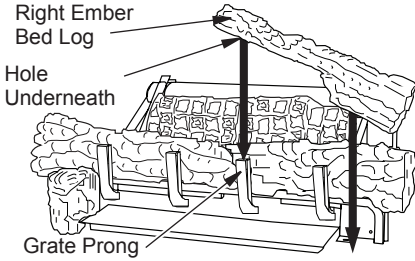

Figure 51 - Installing Right Ember Bed Log

6. The left middle log has a groove on the bottom to sit on the chassis and has to sit on the tab on the back of the left front log as shown in Figure 52.

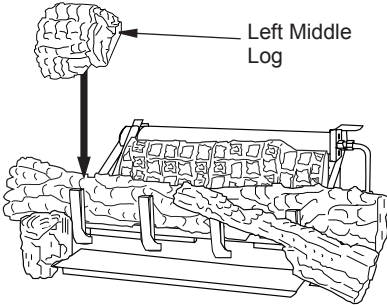

Figure 52 - Installing Left Middle Log

7. The right middle log has a groove on the bottom to sit on the chassis and has to sit on the tab on the back of the right front. The right middle log should have a recess area that fits around the ramp log as shown in Figure 53.

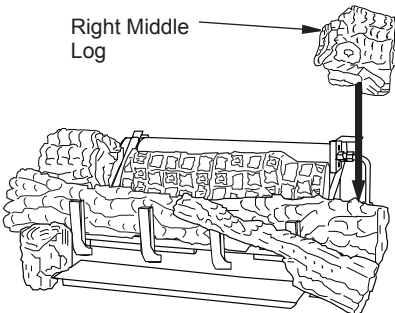

Figure 53 - Installing Right Middle Log

8. The rear middle log should fit between the ramp log and the rear burner. The left and right middle logs have recessed areas for the rear middle log to sit into (See Figure 54). Be careful not to push the rear burner out of position while installing this log.

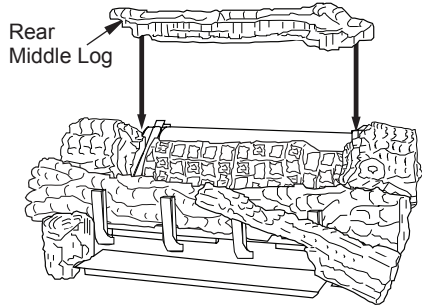

Figure 54 - Installing Rear Middle Log

9. Rest rear log in back corner sections of chassis assembly as shown in Figure 55.

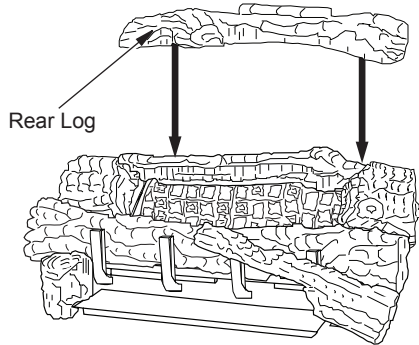

Figure 55 - Installing Rear Log

INSTALLATION

Continued

- Place the left top log onto the rear log and the left middle log. Make sure to place the projection on the bottom of the left top log into the recessed areas on the rear and left middle logs (see Figure 56).

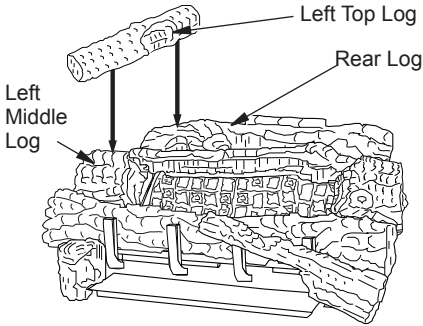

Figure 56 - Installing Left Top Log

- Rest the middle crossover log onto the right middle log and the left front log (see Figure 57). Make sure to match the projection on the bottom of the crossover log with the recess area in the right middle log and the left front log.

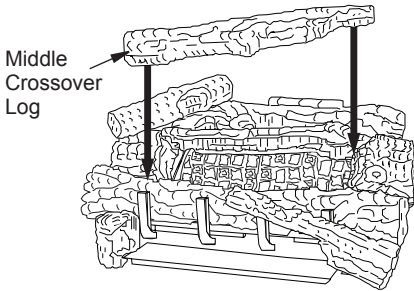

Figure 57 - Installing Middle Crossover Log

- Place the top rear log onto the rear log as shown. The rear log has a projection that will fit into the recess area on the bottom of the top rear log (see Figure 58).

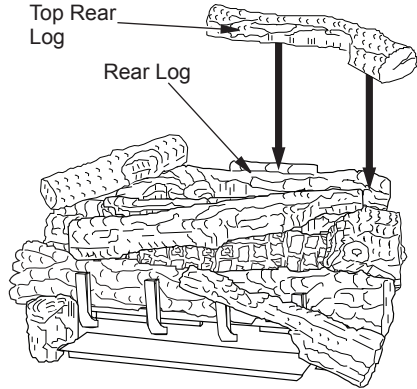

Figure 58 - Installing Top Rear Log

EMBER PLACEMENT - BGE SERIES BURNER SYSTEMS

⚠ WARNING: Do not use any other ember material not supplied with this unit.

⚠ WARNING: Do not operate unit without ember material correctly in place as shown in Figures 60 & 61. Do NOT place ember material anywhere else on the unit. Use only ember material supplied with unit. Excessive or incorrectly placed ember material may produce carbon monoxide or soot.

- Ember Chunk Placement.** The BGE2436 burner systems include three ember chunks that are designed to fit over shoulder screws on the ember pan burner. The bottom of each ember chunk has a hole for securing the ember chunk in place when it is placed over a shoulder screw. Place the ember chunks as shown in Figure 59 on page 27 by placing the ember chunk with the number "1" on the left, "2" in the center, and "3" on the right. These numbers are embossed on the back of each piece for identification purposes. Please note that BGE18 burner systems do not include ember chunks.

INSTALLATION

Continued

2. Two ember materials are supplied with this log set. Platinum Bright Embers give a bright glow appearing as hot coals. Should embers need replacing, see *Parts*, page 44.

Platinum Bright Ember placement. Add embers to front, flat burner. Gently remove embers from bag. Separate pieces of ember material and place on surface of flat burner just behind horizontal ports as shown in Figure 60.

Rock Wool placement. Place rock wool

material on front flat burner in areas away from ports as shown in Figure 61.

3. Add lava rock and small decorative logs around base of heater if desired. **DO NOT place rock or additional logs on front burner or on logs.** Placing any material on unit other than ember material on front burner may result in production of carbon monoxide or soot. Use lava rock to hide wires from switch/log to control valve. Place switch/log so the switch is easy to access.

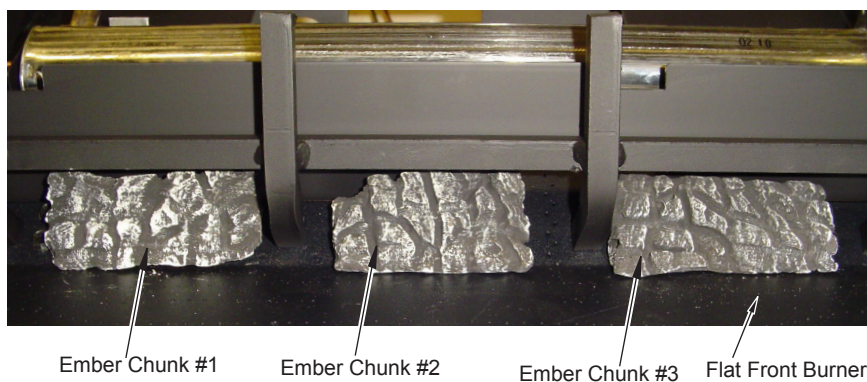

Figure 59 - Ember Chunk Placement BGE2436 Series



Figure 60 - Platinum Bright Embers for BGE Series



**Figure 61 - Placement of Rock Wool for BGE Series
(shown with Platinum Bright Embers)**

OPERATION

NOTICE: During initial operation of new heater, burning logs will give off a paper-burning smell. Orange flame will also be present. Open damper or window to vent smell. This will only last a few hours.



WARNING:

- If fireplace has glass doors, never operate this heater with glass doors closed. If you operate heater with doors closed, heat buildup inside fireplace will cause glass to burst. Make sure there are no obstructions across openings of fireplace.
- You must operate this heater with a fireplace screen in place. Make sure fireplace screen is closed before running heater.



WARNING: Damper handle will be hot if heater has been running.



CAUTION: Do not try to adjust heating levels by using the equipment shutoff valve.

**FOR YOUR SAFETY
READ BEFORE LIGHTING**



WARNING: If you do not follow these instructions exactly, a fire or explosion may result causing property damage, personal injury or loss of life.

- A. This appliance has a pilot that is equipped with an ignition device which automatically lights the pilot. Do not light the pilot by hand.
- B. **BEFORE LIGHTING** smell all around the appliance area for gas. Be sure to smell next to the floor because some

gas is heavier than air and will settle on the floor.

WHAT TO DO IF YOU SMELL GAS

- Do not try to light any appliance.
 - Do not touch any electric switch; do not use any phone in your building.
 - Immediately call your gas supplier from a neighbor's phone. Follow the gas supplier's instructions.
 - If you cannot reach your gas supplier, call the fire department.
- C. Do not use this appliance if any part has been under water. Immediately call a qualified service technician to inspect the appliance and to replace any part of the control system and any gas control which has been under water.

LIGHTING INSTRUCTIONS

1. STOP! Read the safety information.
2. Make sure equipment shutoff valve is fully open.
3. Press any button on the remote to power the remote on. If you see a Lock icon and the word "Unlock" in the lower left corner of the screen you will need to unlock the screen by pressing "Unlock" and "OK".
4. Press "On" and "OK". It may take up to 4 seconds before the control unit processes the command. You will hear a beep from the control unit and the pilot will start to spark before lighting.

Note: You may be running this heater for the first time after hooking up to gas supply. If so, you may have to restart the unit several of times to allow the air to bleed from the system.

TO TURN OFF GAS TO APPLIANCE

1. Press OFF (bottom button) on the remote control.
2. Close equipment shutoff valve.

OPERATION

Continued

REMOTE CONTROL OPERATION

The remote control contains:

1. LCD display
2. Four buttons:
 - OFF button
 - Left button
 - Middle button
 - Right button
3. Battery Case (on the Back)

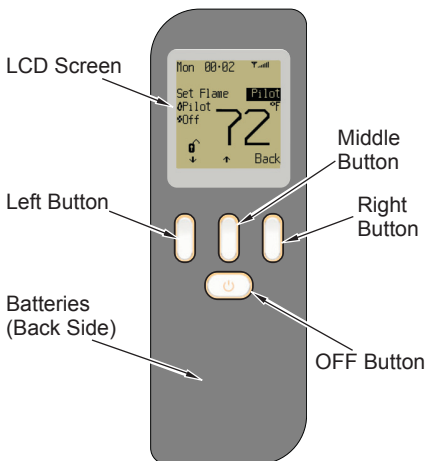

Figure 62 - Remote Control

LCD DISPLAY

The LCD screen shows information about the instructions given by the user (desired status) and the current situation of the device (actual status). It also helps us select our choices, see Figure 63.

- A: Day of the week
- B: Time
- C: Signal Strength
- D: Selected working mode
- E: Selected setting
- F: Current Flame status
- G: Current fan status
- H: Current room temperature
- I: Child lock status
- J: Button labels (explained below)

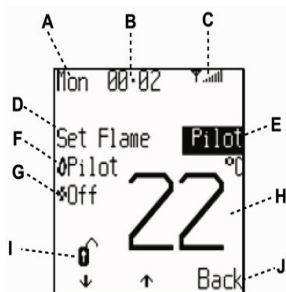

Figure 63 - LCD Display

The screen changes depending on the input from the buttons, but the bottom row always displays the button function labels (see Figure 64). The functions of each button depends on the options available on the current screen (except for the OFF button which has always the same function).

Note: The bottom row of the screen is indicating buttons functionality. In this case:

- LEFT (↓) button decreases the flame level
- MIDDLE (↑) button increases the flame level
- RIGHT (Back) button goes back to the previous screen (see Figure 64).

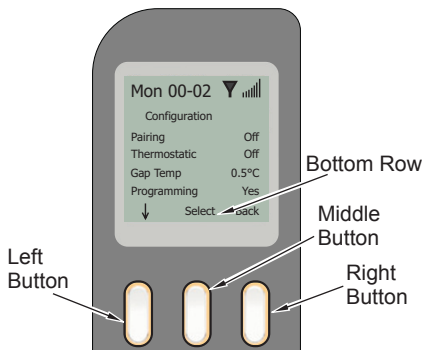

Figure 64 - Screen Changes

OFF BUTTON

This button switches off the appliance. If it is pressed and held for more than 40 seconds, the configuration menu is accessed.

LEFT, MIDDLE AND RIGHT BUTTON

These buttons change their function as shown by the on-screen labels. For some screens a button may have no function and is inactive. The active buttons for a particular screen are initially lit for 5 seconds to indicate that they are active.

OPERATION

Continued

MENU SYSTEM

The remote is organized by means of a menu system.

After batteries are installed the first time, the remote starts at the "OFF" screen (it is possible that the remote is locked in the "OFF" screen: to unlock it just press the button below "Unlock", and then "OK". See Figure 65).

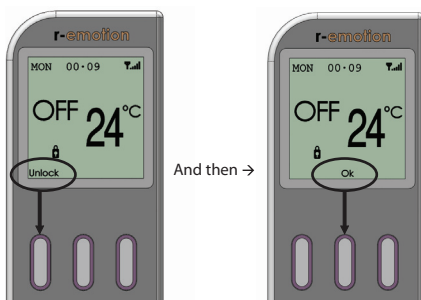

Figure 65 - Menu System

SWITCHING ON

IMPORTANT: When lighting the pilot and burner for the first time, air will be present in the system that must be purged.

The lighting sequence may have to be repeated 10 to 15 times before gas reaches the pilot. This is normal.

To turn the system on, press "On" (left button) and "OK" (middle button). A beep from the control module will be heard and the ignition process will start. This will take up to 20 seconds. Note that while in operation the signal bars will disappear for a few moments. If the pilot and burner do not light, press the "Off" button, wait 15 seconds then repeat the ignition steps from the beginning of this paragraph. Note: each ignition step is accompanied by two short series of ignition sparks at the pilot.

ADJUST MENU

Before using the remote, there are various settings which should be made, such as the date, the language, the autolock option and the comfort temperature.

For doing this, press "Menu" and then press "Select" to chose "Adjust Menu". There the options shown in Figure 66, can be set. To change any of these settings use the down arrow to select the feature and then press "Select" and "Change" to change the setting.

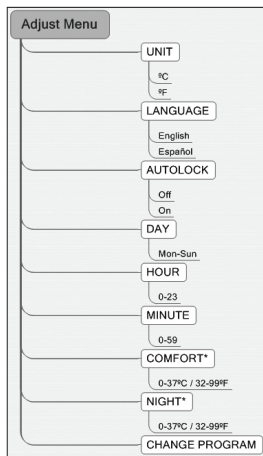

Available after PROGRAM MODE is enabled, see PROGRAM MODE section on next page.

Figure 66 - Adjusting Menu

SETTING THE CONTROL MODE

There are three different modes for controlling the appliance:

- Manual
- Auto
- Program

In Manual mode the main burner can be switched on and off.

Auto mode allows you to set a temperature, while in Manual mode the flame level may be set to HIGH, MEDIUM, or LOW. Program mode offers automatic temperature control for specific times of the day.

In the initial screen when the remote is turned on, three options are available: AUTO, MANUAL and MENU.

Auto and Manual are two of the three different modes for controlling the appliance with the remote.

MANUAL MODE

If "Manual" is pressed, the flame setting appears as the selected setting. In the bottom row, ↓ and ↑ appear, indicating that the flame level can be changed by pressing the left or middle button. Pressing "Back" (right button) returns to the initial screen (see Figure 64, page 29).

Note that a safety temperature can be set in the configuration menu. This specifies the maximum permitted room temperature. This temperature can never be set higher than 40°C (104°F).

OPERATION

Continued

AUTO MODE

If "Auto" is pressed in the initial screen, 25°C (77°F) appears as the desired temperature in the selected setting. In the bottom row, ↓ and ↑ appear, indicating that we can change the desired temperature value by just pressing the left or middle button. In auto mode the appliance heats until this temperature is reached. Pressing "Back" (right button), returns to the initial screen.

The Auto mode feature is optional and can be enabled or disabled in the configuration menu by changing "Thermostat" to either "Yes" (enabled) or to "No" (disabled). Access to the configuration menu is described in the next section.

PROGRAMMING

PROGRAM MODE

A program mode is available if desired. This mode allows the remote control to operate the gas log set in either weekly or daily settings. To enable the program mode access the configuration menu.

CONFIGURATION MENU ACCESS: Press and hold the "OFF" button (⏻) on the remote control for 40 seconds. During this time, the screen will go blank for a few seconds, this is normal. See Figure 67. After 40 seconds, the configuration menu appears (see Figure 68).

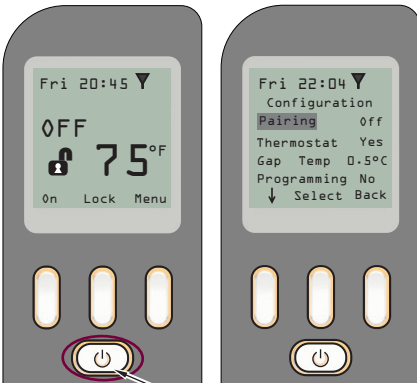

OFF Button
Figure 67 - OFF Button

Press the arrow button (↓) until Programming is highlighted (see Figure 68). If Programming has "No" next to it, press the "Select" button to highlight "No" (see Figures 68 and 69).

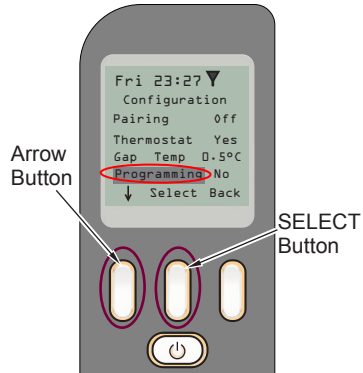

Figure 68 - Programming

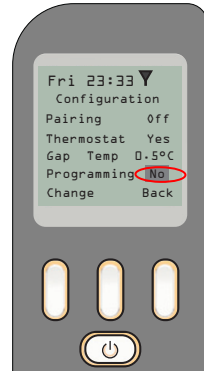

Figure 69 - Highlighting "No"

Press "Change" (left button) to change Programming from "No" to "Yes" (see Figure 70). To return to the main screen, press the "Back" button until you get to the main screen. The main screen is shown in Figure 71, page 32. The PROGRAM MODE is now enabled.

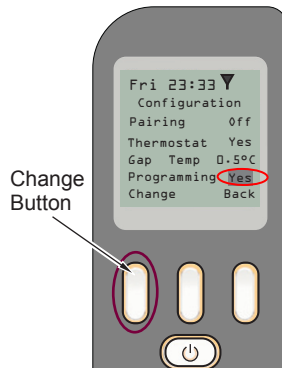

Figure 70 - Changing "No" to "Yes"

OPERATION

Continued

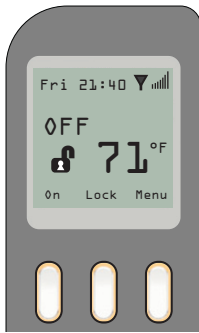

Figure 71 - Main screen

There are two types of program mode: a **daily mode** and a **weekly mode**. In the daily mode, every day uses the same program. In the weekly mode, every day has its own program, so it is possible have a different program for each day of the week (see Figure 72).



Figure 72 - Setting Control Mode

DAY PROGRAMMING MENU (Menu → Adjust Menu → Change Program):

There are 8 menus like this. One for daily, and the others for each day (Monday, Tuesday, Wednesday, Thursday, Friday, Saturday and Sunday, see Figure 73). This day programming screen consists of:

Title: Daily Program.

A: **Selected (including "Daily")**. The selected day can be changed by pressing "Change" (middle button).

B: **Day Schedule Graphic**. This bar displays the program for the whole day by showing the temperature setting for each hour of the day. To access the day schedule graphic, press (↓) (left button). To change the desired temperature, go to the hour you want to change by pressing → (left button) and then press change (middle button). There are 3 temperature settings:

OFF: No temperature control (the appliance is in pilot mode).

NIGHT TEMP: The night temperature is set as desired temperature and the appliance will heat until this temperature is reached.

COMFORT TEMP: The comfort temperature is set as the desired temperature and the appliance will heat until this temperature is reached.

Finally, to launch the program mode, in the main menu, set Program to "On", and select the desired Program Type (Daily or Weekly) as shown in Figure 73.

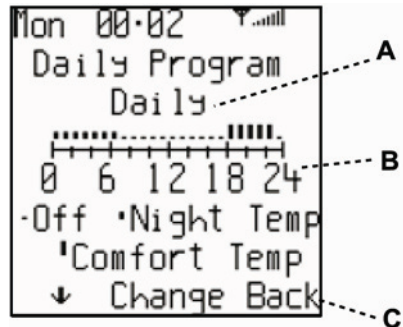

Figure 73 - Day Programming Menu

OTHER FEATURES

How to lock and unlock the remote (child lock)

To unlock the remote, press the "Unlock" button and "OK".

To lock the remote, in the main screen press "Menu" go to the Lock option, press "Select" and then "Change". The remote will immediately go into locked mode.

OPERATION

Continued

Automatic lock can be selected. This means that if no button is pressed for while, the remote automatically goes into locked mode.

How to select the temperature unit (°C/°F)

In the main screen, press "Menu" button. Select "Adjust Menu" and then select "Unit". To change the temperature unit press "Change" button.

TOUCH PAD OPERATION

This touch control has only 3 buttons for controlling manually the flame of the appliance (see Figure 74).

The touch pad has:

1. Led display
2. ON/OFF button
3. UP button
4. DOWN button

With this control it is possible to turn on the fire, turn off the fire and control the flame level.

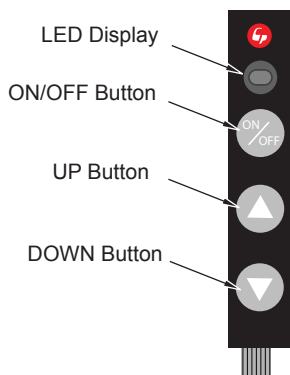

Figure 74 - Touch Pad Control

Note: The touch pad includes a red LED display light. If the LED remains on, the black plug is connected upside down. Unplug, turn over, and reconnect.

SWITCHING ON

To turn the system on just press the ON/OFF button. The system will emit a beep and begin the ignition process, which can take about 20 seconds. Once the start up process is complete, the pilot flame is lit.

REGULATING THE FLAME LEVEL.

1. To increase the flame level, press the up button (▲). A beep and a flash of the LED indicate that the system has accepted the order, and the flame will increase instantly (see Figure 74).
2. To decrease the flame level, press the down button (▼). A beep and a flash of the LED indicate that the system has accepted the order, and the flame will decrease instantly (see Figure 74).

SWITCHING OFF

To switch off the fire, the ON/OFF button should be pressed. After the system has emitted a beep, the fire switches off.

⚠ WARNING: Do not convert heater to use different fuel type. Only use heater with fuel type specified.

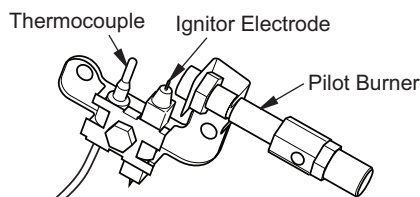

Figure 75 - Pilot (Natural)

INSPECTING BURNERS

Check pilot flame pattern and burner flame patterns often.

PILOT FLAME PATTERN

Figure 76, page 34 shows a correct pilot flame pattern. Figure 77, page 34 shows an incorrect pilot flame pattern. The incorrect pilot flame is not touching the thermocouple. This will cause the thermocouple to cool. When the thermocouple cools, the heater will shut down. If pilot flame pattern is incorrect, as shown in Figure 77, page 34.

- turn heater off (see [To Turn Off Gas to Appliance](#), page 278)
- see [Troubleshooting](#), page 37

Note: The pilot flame on natural gas units will have a slight curve, but flame should be blue and have no yellow or orange color.

INSPECTING BURNERS

Continued

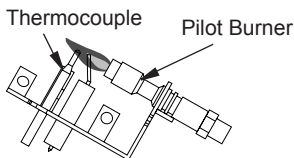

Figure 76 - Correct Pilot Flame Pattern
(Your pilot may vary from pilots shown)

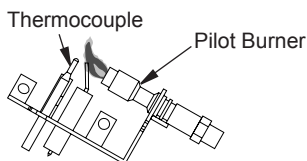

Figure 77 - Incorrect Pilot Flame Pattern
(Your pilot may vary from pilots shown)

FRONT BURNER FLAME PATTERN

The front burner has a blue flame and should not have any yellow tipping at the top of the blue flame.

MIDDLE BURNER FLAME PATTERN

Figure 78, shows correct front burner flame pattern. Figure 79, shows incorrect front burner flame pattern. The incorrect burner flame pattern shows yellow tipping at top of blue flame.

WARNING: If yellow tipping occurs, your heater could produce increased levels of carbon monoxide. If middle burner flame pattern shows yellow tipping, follow instructions at bottom of this page. Yellow flame on rear burner is normal.

NOTICE: Do not mistake orange flames with yellow tipping. Dirt or other fine particles are burned by heater, causing brief patches of orange flame.

If front burner flame pattern is incorrect, as shown in Figure 79.

- turn heater off (see *To Turn Off Gas to Appliance*, page 28).
- see *Troubleshooting*, page 37

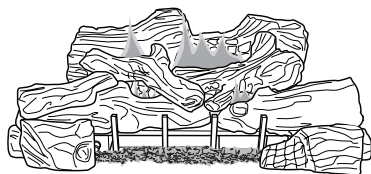

Figure 78 - Correct Middle Burner Flame Pattern

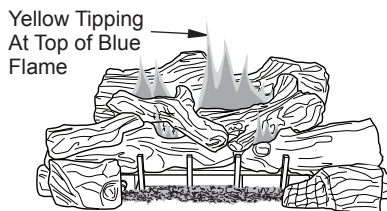

Figure 79 - Incorrect Middle Burner Flame Pattern

CLEANING AND MAINTENANCE

WARNING: Turn off heater and let cool before cleaning.

CAUTION: You must keep control areas, burners and circulating air passageways of heater clean. Inspect these areas of heater before each use. Have heater inspected yearly by a qualified service person. Heater may need more frequent cleaning due to excessive lint from carpeting, pet hair, bedding material, etc.

WARNING: Failure to keep the primary air opening(s) of the burner(s) clean may result in sooting and property damage.

CLEANING AND MAINTENANCE

Continued

BURNER ORIFICE HOLDER AND PILOT AIR INLET HOLE

The primary air inlet holes allow the proper amount of air to mix with the gas. This provides a clean burning flame. Keep these holes clear of dust, dirt, lint and pet hair. Clean these air inlet holes prior to each heating season. Blocked air holes will create soot. We recommend that you clean the unit every three months during operation and have heater inspected yearly by a qualified service person.

We also recommend that you keep the burner tube and pilot assembly clean and free of dust and dirt. To clean these parts we recommend using compressed air no greater than 30 PSI. Your local computer store, hardware store or home center may carry compressed air in a can. If using compressed air in a can, please follow the directions on the can. If you don't follow directions on the can, you could damage the pilot assembly.

1. Shut off unit, including pilot. Allow unit to cool for at least thirty minutes.
2. Inspect burner, pilot and primary air inlet holes on orifice holder for dust and dirt (see Figure 80).
3. Blow air through the ports/slots and holes in the burner.

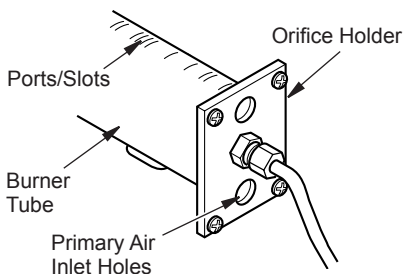

Figure 80 - Orifice Holder On Outlet Burner Tube

4. Check orifice holder located at the end of the burner tube again. Remove any large particles of dust, dirt, lint or pet hair with a soft cloth or vacuum cleaner nozzle.
5. Blow air into the primary air holes on the orifice holder.
6. In case any large clumps of dust have now been pushed into the burner repeat steps 3 and 4.

Clean pilot assembly also. A yellow tip on the pilot flame indicates dust and dirt in the pilot assembly. There is a small pilot air inlet hole about 2" from where the pilot flame comes out of the pilot assembly (see Figure 81). With the unit off, lightly blow air through the air inlet hole. You may blow through a drinking straw if compressed air is not available.

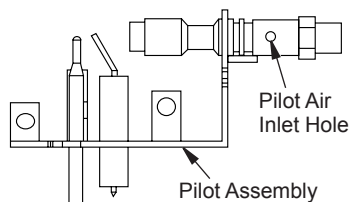

Figure 81 - Pilot Inlet Air Hole (Your pilot may vary from pilot shown)

LOGS

- If you remove logs for cleaning, refer to [Installing Logs](#), page 18, to properly replace logs.
- Replace log(s) if broken or chipped (dime-sized or larger).

MAIN BURNER

Periodically inspect all burner flame holes with the heater running. All slotted burner flame holes should be open with yellow flame present. All round burner flame holes should be open with a small blue flame present. Some burner flame holes may become blocked by debris or rust, with no flame present. If so, turn off heater and let cool. Remove blockage, blocked burner flame holes will create soot.

WIRING DIAGRAM

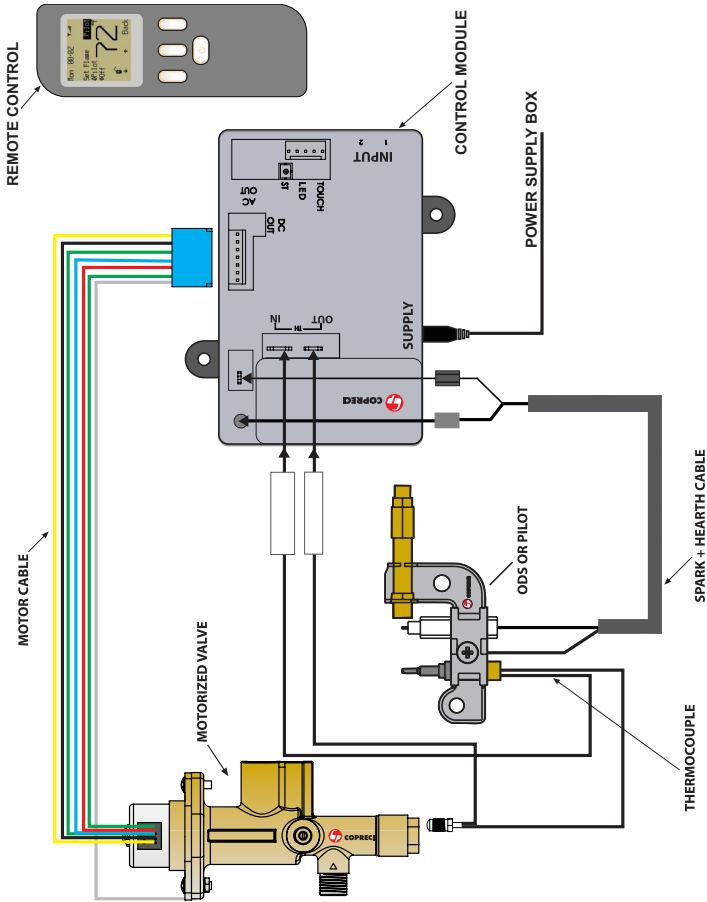

SPECIFICATIONS

BGE18PE

- Rating (Variable): 24,000/30,000 Btu/Hr
- Type Gas: Propane/LP
- Ignition: Electronic
- Manifold Pressure: 8" W.C.
- Inlet Gas Pressure (in. of water):
Max - 14" W.C., Min* - 11" W.C.

BGE18NE

- Rating (Variable): 21,000/30,000 Btu/Hr
- Type Gas: Natural
- Ignition: Electronic
- Manifold Pressure: 4.5" W.C.
- Inlet Gas Pressure (in. of water):
Max - 10.5" W.C., Min* - 5" W.C.

BGE2436PE

- Rating (Variable): 30,000/39,000 Btu/Hr
- Type Gas: Propane/LP
- Ignition: Electronic
- Manifold Pressure: 8" W.C.
- Inlet Gas Pressure (in. of water):
Max - 14" W.C., Min* - 11" W.C.

BGE2436NE

- Rating (Variable): 26,000/39,000 Btu/Hr
- Type Gas: Natural
- Ignition: Electronic
- Manifold Pressure: 4.5" W.C.
- Inlet Gas Pressure (in. of water):
Max - 10.5" W.C., Min* - 5" W.C.

*For purpose of input adjustment

TROUBLESHOOTING

⚠ WARNING: Turn off heater and let cool before servicing. Only a qualified service person should service and repair heater.

⚠ CAUTION: Never use a wire, needle or similar object to clean ODS/pilot. This can damage ODS/pilot unit.

Note: All troubleshooting items are listed in order of operation.

OBSERVED PROBLEM	POSSIBLE CAUSE	REMEDY
<p>Either the remote or touch pad buttons are pressed to start the burner ignition sequence and there is no function or response.</p>	1. Missing or weak batteries at power supply box or remote. Control module may beep 10 times or may not beep at all. LCD display may show "BATTERY ERROR".	1. Check batteries and replace if needed. (Batteries in the power supply box can be tested with a multimeter at the two connections at the back of the battery housing where the red and black wires are connected. Set the multimeter to DC voltage, initiate the ignition sequence, and observe the voltage while the system is lighting (under load). The system will not function under 3.8 volts and batteries should be replaced if the voltage is under 4.0 volts.)
	2. Unplugged power supply (battery) box	2. Plug power supply box to module see page 16.
	3. Touch pad not plugged in to module or plugged in incorrectly	3. Plug touch pad in module see page 16, figure 19. Check to see it is positioned as shown.
	4. Control valve wiring harness not plugged in or not in proper position	4. Check to see that the control valve wiring harness' blue connector is plugged in to the module. Check to see that it is aligned with the mating pins. If any pins are visible, then the connector is not in the correct position. If this is the case, disconnect, align, and reconnect to the module.
	5. Remote not communicating with control module	5. Check the display on the remote for signal bars. If the display is blank, press any button one time to activate the display. Watch the display for 30 seconds and observe if the signal bars are shown. (The remote communicates with the module periodically. It doesn't communicate with the module continuously to conserve battery power.) If the remote is communicating with the module, signal bars will be displayed temporarily. If they are not displayed any, verify the batteries are new and installed correctly. If the signal bars still do not display, follow the Re-Pairing instructions on page 17.

TROUBLESHOOTING

Continued

OBSERVED PROBLEM	POSSIBLE CAUSE	REMEDY
Either the remote or touch pad buttons are pressed to start the burner ignition sequence and there is no function or response. (Continued from page 37).	6. LED is blinking	6. This indicates the battery power is low. Replace the batteries in the power supply box.
	7. Ignitor cable is not connected	7. Check the ignitor connection at both the control module and the ods pilot. Connect if loose.
	8. Ignitor cable pinched or wet	8. Free ignitor cable if pinched by any metal or tubing. Keep ignitor cable dry.
	9. Broken Ignitor cable.	9. Replace wire harness including ignitor cable.
	10. Ignitor electrode positioned wrong.	10. Replace ods pilot assembly.
	11. Ignitor electrode broken.	11. Replace ods pilot assembly.
	12. Control module sounds 2 cycles of 3 beeps; LCD display may show ROM ERROR	12. Replace control module
	13. Control module sounds 2 cycles of 5 beeps; LCD display may show SUPPORT ERROR	13. Ground cable from control valve wiring harness is not grounding properly. Reposition spade terminal so that it makes contact with burner chassis metal or valve body.
	14. Bad reception from remote	14. Change batteries in remote. Check reception of signal from a shorter distance. If still not working, try changing the channel in the configuration menu. If this does not fix the problem, reset the channel to A and follow the instructions in Re-Pairing on page 17. Replace remote and control module as a final action.
	15. If LED on touch pad is continuously on, the cable is connected the wrong way.	15. Disconnect the touch pad between the long and short cables, turn the short cable with the touch pad over and reconnect.
	16. The control module sounds 2 cycles of 5 beeps. The wiring assembly from the control valve is disconnected or broken.	16. Connect the wiring harness at the control module. Replace the valve assembly if all other cause/remedies fail to correct his problem.

TROUBLESHOOTING

Continued

OBSERVED PROBLEM	POSSIBLE CAUSE	REMEDY
When ignitor button is pressed on the remote or touch pad, the pilot sparks but there is no ignition.	1. Gas supply turned off or equipment shutoff valve closed	1. Turn on gas supply or open equipment shutoff valve.
	2. Air in gas lines.	2. Continue turning the burner system ON and OFF. Repeat igniting operation until air is removed. On first time ignitions, air in the lines is common and it is not uncommon to repeat the ignition sequence 10 to 15 times before enough gas is at the ods pilot for it to light.
	3. Thermocouple circuit between the control valve and the control module is open.	3. Check the thermocouple connection at the control valve and also at the control module. The thermocouple connection at the control valve should be hand tight plus 1/4 to 1/2 turn. You should not be able to loosen the thermocouple at the control valve with your hand. Check the thermocouple terminal connection at the control module. If it is loose, remove it with needle nose pliers, using the pliers, slightly close the terminal's opening and reinstall on to the control module.
	4. No gas to the ods pilot	4. While the pilot is sparking, check for gas flow at the ods pilot. If flow is present, try to light the pilot with a long reach lighter. If it will not light but the flame is disturbed, air is in the line. Cycle through the ignition sequence to clear the line of air until gas is present. If no flow is present at the gas valve, check to see all shut off valves are open. Verify proper pressure is supplied to the valve. Excessive pressure can lock out the appliance's regulator. Also check to see that the wiring harness from the control valve is properly connected at the control module. The wiring harness connection housing can be identified by it's blue connector housing.
	5. Depleted gas supply (propane/LP only)	5. Contact local propane/LP gas company.
	6. Valve cable is disconnected or broken.	6. Connect valve cable correctly
	7. ODS pilot is clogged	7. Clean ods pilot (see Cleaning and Maintenance , page 34) or replace ods pilot assembly.
	8. Gas regulator setting is not correct	8. Replace gas regulator

TROUBLESHOOTING

Continued

OBSERVED PROBLEM	POSSIBLE CAUSE	REMEDY
ODS pilot lights but pilot flame goes out before burners light.	1. Equipment shutoff valve not fully open	1. Fully open equipment shutoff valve.
	2. Missing or weak batteries at power supply box or remote.	2. Check batteries and replace if needed. (Batteries in the power supply box can be tested with a multimeter at the two connections at the back of the battery housing where the red and black wires are connected. Set the multimeter to DC voltage, initiate the ignition sequence, and observe the voltage while the system is lighting (under load). The system will not function under 3.8 volts and batteries should be replaced if the voltage is under 4.0 volts.)
	3. Thermocouple circuit between the ods pilot and control module is loose or damaged.	3. Check thermocouple terminal connection at the control module. If it is loose, remove it with needle nose pliers, using the pliers, slightly close the terminal's opening and reinstall on to the control module.
	4. Pilot flame not touching thermocouple, which allows thermocouple to cool, causing pilot flame to go out. This problem could be caused by one or both of the following: A) Low gas pressure or B) Dirty or partially clogged ODS pilot.	4. A) Contact local natural or propane/LP gas company. B) Clean ODS pilot (see Cleaning and Maintenance , page 34) or replace ODS pilot assembly.
	5. Thermocouple damaged	5. Replace ods pilot assembly.
	6. Control valve damaged.	6. Replace control valve
Burner system lights from remote but not from touch pad	1. Touch pad cable disconnected or broken	1. Connect or replace touch pad and cable.
	2. Defective touch pad	2. Replace touch pad
Burner system does not ignite the burner while the remote is in the program mode.	1. Program mode does not work if soft start is deactivated.	1. Activate soft start in the remote.
Burner system shuts off after operating 6 seconds then sounds 5 beeps.	1. Short in touch pad wiring. BUT-TON ERROR is shown in remote display.	1. Replace touch pad and wiring harness.
Low battery power in remote.	1. Batteries are weak. LOW BATTERY is shown in remote display.	1. Replace batteries in remote.

TROUBLESHOOTING

Continued

OBSERVED PROBLEM	POSSIBLE CAUSE	REMEDY
Burner system shuts off. Control module sounds 2 cycles of 3 beeps. CONFIG. ERROR is shown in remote display.	1. Faulty control module	1. Replace control module.
Burner system shuts off. Control module sounds 2 cycles of 3 beeps. EEPRON ERROR is shown in remote display.	1. Remote and control module not communicating properly	1. Follow Re-Pairing instructions on page 17 to re-pair remote to control module
	2. Faulty control module	2. Replace control module
Burner system shuts off. Control module sounds 20 beeps.	1. Loss of communication between control module and remote after 18 minutes.	1. Either the remote is too far from the burner system or the remote needs new batteries. The remote should work within 20 feet of the burner system. If it does not, replace the batteries in the remote and battery supply box.
Burner system shuts off. Control module sounds 1 long beep. Remote displays TEMP ERROR.	1. Control module is too hot	1. Check to see the fireplace size meets the minimum requirements. Call technical service.
Burner systems shuts off. Remote displays OVER TEMPERATURE.	1. The SAFETY temperature setting in the remote has shut the burner system off.	1. The remote includes a shut off that is preset at 40C (104F). If the remote is placed in a location that is at or above this temperature it will shut the burner system off. Placing the remote on a mantel may result in this problem. If it occurs, relocate the remote to a cooler location.
Burner system lights or shuts off without touching the remote.	1. More than one burner system is present and operating on the same frequency.	1. Follow the Re-Pairing section to re-pair the burner system(s). One burner system may be left on the original frequency.

TROUBLESHOOTING

Continued

OBSERVED PROBLEM	POSSIBLE CAUSE	REMEDY
Burners do not light after ODS/pilot is lit	1. Inlet gas pressure is too low	1. Contact local natural or propane/LP gas company
	2. Burner orifice(s) clogged	2. Clean burner(s) (see <i>Cleaning and Maintenance</i> , page 34) or replace burner orifice(s)
	3. Mislocated crossover tube	3. Contact qualified service person
Delayed ignition of one or both burners	1. Manifold pressure is too low	1. Contact local natural or propane/LP gas company
	2. Burner orifice(s) clogged	2. Clean burner(s) (see <i>Cleaning and Maintenance</i> , page 34) or replace burner orifice(s)
	3. Mislocated crossover tube	3. Contact qualified service person
Burner backfiring during combustion	1. Burner orifice is clogged or damaged	1. Clean burner (see <i>Cleaning and Maintenance</i> , page 34) or replace burner orifice
	2. Damaged burner	2. Replace damaged burner
	3. Gas regulator defective	3. Replace gas regulator
Yellow flame in middle burner during burner combustion	1. Not enough air	1. Check burner(s) for dirt and debris. If found, clean burner(s) (see <i>Cleaning and Maintenance</i> , page 34)
	2. Gas regulator defective	2. Replace gas regulator
Slight smoke or odor during initial operation	1. Residues from manufacturing processes and logs curing	1. Problem will stop after a few hours of operation
Heater produces a whistling noise when burners are lit	1. Set the unit to HI by using the remote when burners are cold	1. Set the unit to LO by using the remote and let warm up for a minute
	2. Air in gas line	2. Operate burners until air is removed from line. Have gas line checked by local natural or propane/LP gas company
	3. Air passageways on heater blocked	3. Observe minimum installation clearances (see pages 9 through 12)
	4. Dirty or partially clogged burner orifice(s)	4. Clean burners (see <i>Cleaning and Maintenance</i> , page 34) or replace burner orifice(s)
White powder residue forming within burner box or on adjacent walls or furniture	1. When heated, vapors from furniture polish, wax, carpet cleaners, etc. may turn into white powder residue	1. Turn heater off when using furniture polish, wax, carpet cleaners or similar products
Moisture/condensation noticed on windows	1. Not enough combustion/ventilation air	1. Refer to <i>Air for Combustion and Ventilation</i> requirements (page 6)
Heater produces a clicking/ticking noise just after burners are lit or shut off	1. Metal expanding while heating or contracting while cooling	1. This is normal with most heaters. If noise is excessive, contact qualified service person

TROUBLESHOOTING

Continued



WARNING: If you smell gas

- Shut off gas supply.
- Do not try to light any appliance.
- Do not touch any electrical switch; do not use any phone in your building.
- Immediately call your gas supplier from a neighbor's phone. Follow the gas supplier's instructions.
- If you cannot reach your gas supplier, call the fire department.

IMPORTANT: Operating heater where impurities in air exist may create odors. Cleaning supplies, paint, paint remover, cigarette smoke, cements and glues, new carpet or textiles, etc., create fumes. These fumes may mix with combustion air and create odors. These odors will disappear over time.

OBSERVED PROBLEM	POSSIBLE CAUSE	REMEDY
Heater produces unwanted odors	1. Heater burning vapors from paint, hair spray, glues, cleaners, chemicals, new carpet, etc. (See <i>IMPORTANT</i> statement above)	1. Open window to ventilate room. Stop using odor causing products while heater is running
	2. Low fuel supply (propane/LP only)	2. Refill supply tank (propane/LP only)
	3. Gas leak. See Warning statement at top of page	3. Locate and correct all leaks (see <i>Checking Gas Connections</i> , page 15)
Heater shuts off in use (ODS operates)	1. Not enough fresh air is available	1. Open window and/or door for ventilation
	2. Low line pressure	2. Contact local natural or propane/LP gas company
	3. ODS/pilot is partially clogged	3. Clean ODS/pilot (see <i>Cleaning and Maintenance</i> , page 34)
Gas odor even when control knob is in OFF position	1. Gas leak. See Warning statement at top of page	1. Locate and correct all leaks (see <i>Checking Gas Connections</i> , page 15)
	2. Control valve or gas control defective	2. Replace control valve or gas control
Gas odor during combustion	1. Foreign matter between control valve and burner	1. Take apart gas tubing and remove foreign matter
	2. Gas leak. See Warning statement at top of page	2. Locate and correct all leaks (see <i>Checking Gas Connections</i> , page 15)
Log set cycles to pilot, but room temperature drops to a lower than ideal level before log set comes back on	1. Optional Hand-held remote control is too close to heater	1. Move hand-held remote control unit farther away from the heater

PARTS

REMOTE-READY CONTROL MODELS BGE18NE, BGE18PE, BGE2436NE, BGE2436PE

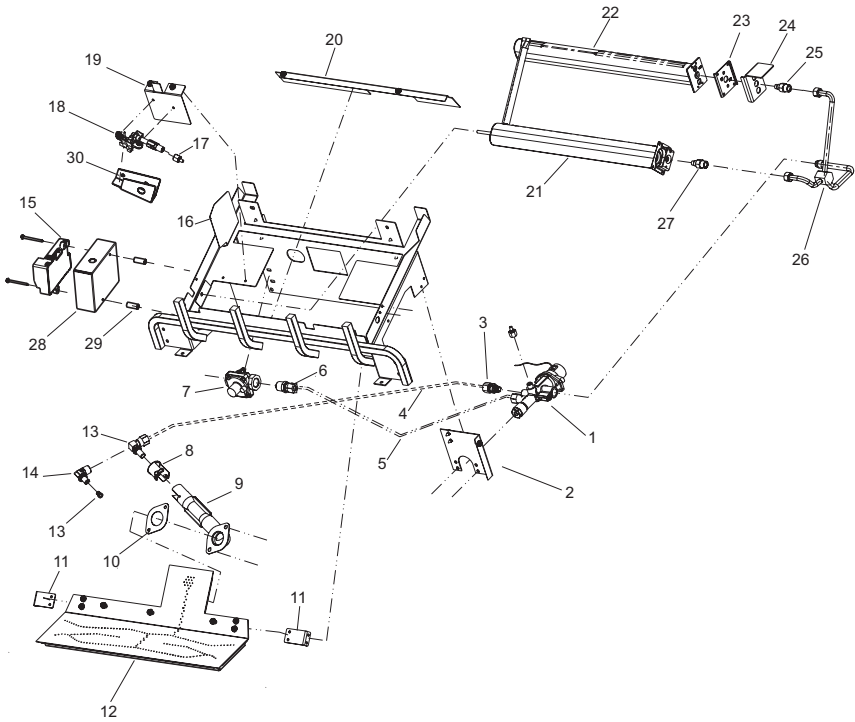

PARTS AVAILABLE NOT SHOWN

KEY NO.	PART NO.	DESCRIPTION	BGE18NR	BGE18PR	BGE2436NR	BGE2436PR	QTY.
	120466-01	Flex Tube	•	•	•	•	1
	100563-01	Warning Plate	•	•	•	•	1
	125782-01	Lighting Instruction Plate	•	•	•	•	1
	100639-12	Caution Decal	•	•	•	•	1
	101137-02	Hardware Kit	•	•	•	•	1
	GA6060	Lava Rock	•	•	•	•	1
	125557-01	Left Ember Chunk #1			•	•	1
	125557-02	Middle Ember Chunk #2			•	•	1
	125557-03	Right Ember Chunk #3			•	•	1
	125070-01	Platinum Embers	•	•	•	•	1
	125071-01	Rockwool Embers	•	•	•	•	1
	125775-01	Control, T-STAT Remote	•	•	•	•	1
	120761-01RVCK	Bracket, Left Log Support			•	•	1
	125499-01	Bracket, Right Log Support			•	•	1
	125781-01	Harness, Pilot Ignitor	•	•	•	•	1
	125783-01	Screw, Min. Rate	•				1
	125783-02	Screw, Min. Rate		•			1
	125783-03	Screw, Min. Rate			•		1
	125783-04	Screw, Min. Rate				•	1
	125776-01	Supply, Battery Power	•	•	•	•	1
	125882-01	Touch Pad Manual Control	•	•	•	•	1
	125882-02	Touch Pad Wire Harness	•	•	•	•	1

** Not a field replaceable part.

PARTS

This list contains replaceable parts used in your heater. When ordering parts, follow the instructions listed under Replacement Parts on page 51 of this manual.

KEY NO.	PART NO.	DESCRIPTION	BGE18NE	BGE18PE	BGE2436NE	BGE2436PE	QTY.
1	125919-01	Electronic Valve Kit	•		•		1
	125919-04	Electronic Valve Kit		•		•	1
2	125800-01	Bracket, Valve		•	•	•	1
3	125816-01	Fitting, Tube. 375 - .125 NPTF	•	•	•	•	1
4	125817-02	Tube, Orifice to Valve			•	•	2
5	125817-01	Tube, Regulator to Valve	•	•	•	•	1
6	098264-02	Connector, Male 3/8 NPTF	•	•	•	•	1
7	099415-24	Regulator, Gas LP.		•		•	1
	099415-28	Regulator, Gas NG.	•		•		1
8	112829-02	Shutter, Air	•	•	•	•	1
9	119321-01	Tube, Venturi	•	•	•	•	1
10	119795-01	Gasket, Burner	•	•	•	•	1
11	125301-01	Bracket, Pan Burner Support	•	•	•	•	2
12	125306-01	Assy, Pan Burner BGE2436			•	•	1
	125306-02	Assy, Pan Burner BGE18	•	•			1
13	111819-10	Orifice, Elbow P53 95 110	•			•	1
	111819-06	Orifice, Elbow P53 95 220			•		1
	099056-45	Orifice, 0.028 (PAN)		•			1
14	124933-01	Orifice, Holder 90° Elbow		•			1
15	125777-01	Module, Control Board	•	•	•	•	1
16	125003-01	Shield, Air			•	•	1
17	099387-08	Tube, Pilot	•	•	•	•	1
18	125780-01	Pilot, Electric (NG)	•		•		1
	125780-02	Pilot, Electric (LP)		•		•	1
19	112713-01SA	Bracket, Pilot	•				1
	112713-02RV	Bracket, Pilot		•	•		1
	112713-04	Bracket, Pilot				•	1
20	125489-01	Shield, Air 18" BGE	•	•			1
	125489-02	Shield, Air 24/30/36" BGE			•	•	1
21	112465-01	Burner 18" Ramp Front	•	•			1
	112465-02	Burner 24/30" Ramp Front			•	•	1
22	112466-01	Burner 18" Ramp Rear	•	•			1
	112466-02	Burner 24/30" Ramp Rear			•	•	1
23	107634-01	Plate, Gas (NG only)	•		•		1
24	121005-01RV	Bracket, Air Shield				•	1
25	101004-10	Injector (.0453) Rear Burner				•	1
	101004-11	Injector (.067) Rear Burner			•		1
	101004-12	Injector (.0595) Rear Burner	•				1
	101004-24	Injector (.042) Rear Burner		•			1
26	125801-01	Tube, Inlet	•	•			1
27	101004-04	Injector (.0750) Middle Burner	•				1
	101004-06	Injector (.053) Middle Burner				•	1
	101004-15	Injector (.047) Middle Burner		•			1
	101004-25	Injector (.085) Middle Burner			•		1
28	125844-01	Control Module Heat Shield	•	•	•	•	1
29	122569-01	Aluminum Spacers	•	•	•	•	2
30	125561-01	Pilot Shield	•		•		1

PARTS

LOG MODELS

LBG18-SM, LBG24-SM, LBG30-SM

This list contains replaceable parts used in your heater. When ordering parts, follow the instructions listed under Replacement Parts on page 51 of this manual.

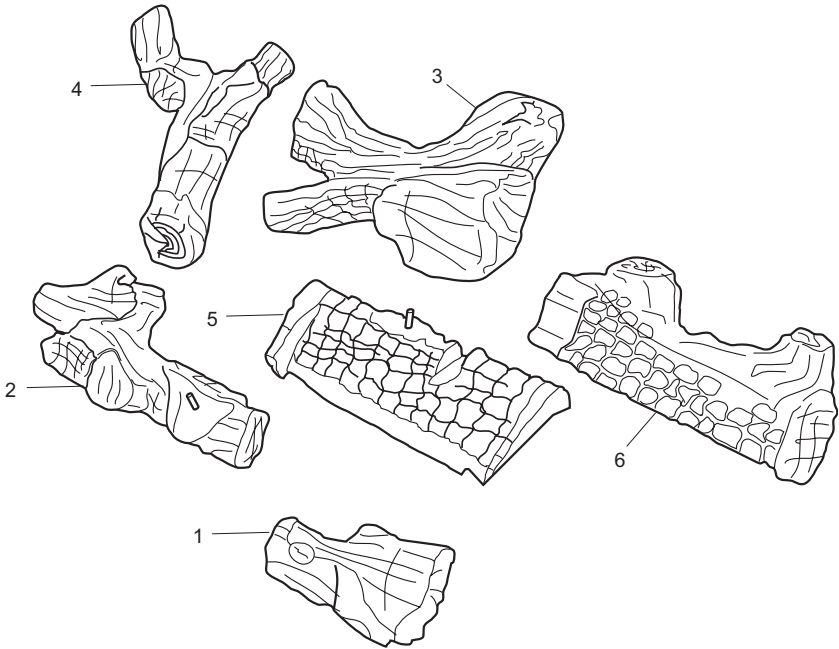

KEY NO.	MODEL NUMBER			DESCRIPTION	QTY
	LBG18-SM	LBG24-SM	LBG30-SM		
1	121699-05	121699-11	121699-17	Front Right Log	1
2	121699-04	121699-10	121699-16	Front Left Log	1
3	121699-02	125683-01	125683-01	Middle Right Log	1
4	121699-03	121699-09	121699-15	Middle Left Log	1
5	121699-01	121699-13	121699-13	Bottom Log (Remote)	1
6	121699-06	121699-12	121699-18	Rear Log	1

PARTS

LOG MODELS LBG36-SM

This list contains replaceable parts used in your heater. When ordering parts, follow the instructions listed under Replacement Parts on page 51 of this manual.

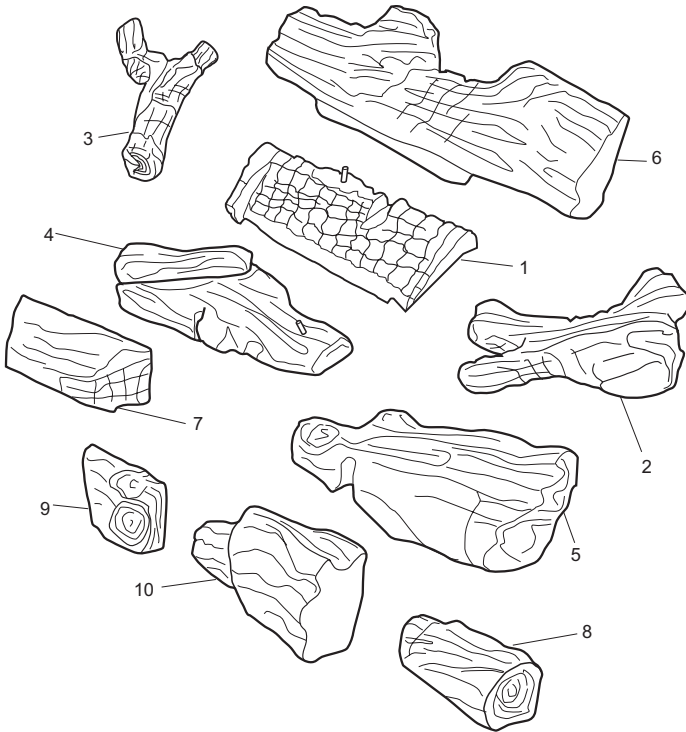

KEY NO.	MODEL NUMBER	DESCRIPTION	QTY
1	121699-13	Bottom Log	1
2	125683-01	Middle Right Log	1
3	121699-15	Middle Left Log	1
4	121699-20	Front Left Log	1
5	121699-21	Front Right Log	1
6	121699-22	Back Log	1
7	121699-23	Left Small Front Log	1
8	121699-24	Right Small Front Log	1
9	121699-25	Left Control Cover Log	1
10	121699-26	Right Control Cover Log	1

PARTS

LOG MODELS

LBG18-RM, LBG24-RM, LBG30-RM

This list contains replaceable parts used in your heater. When ordering parts, follow the instructions listed under Replacement Parts on page 51 of this manual.

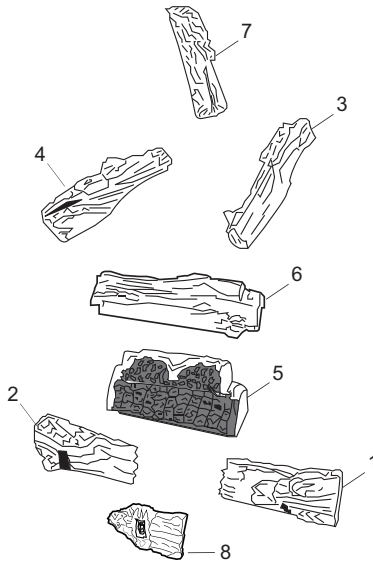

KEY NO.	PART NUMBER			DESCRIPTION	QTY
	LBG18-RM	LBG24-RM	LBG30-RM		
1	125055-13	125055-02	125055-08	Front Right Log	1
2	125055-12	125055-01	125055-07	Front Left Log	1
3	125055-15	125055-04	125055-10	Middle Right Log	1
4	125055-16	125055-05	125055-11	Middle Left Log	1
5	125056-01	125056-02	125056-02	Ramp Log	1
6	125055-14	125055-03	125055-09	Rear Log	1
7	125055-06	125055-06	125055-06	Top Log	1

PARTS

LOG MODELS

LBG18-CM, LBG24-CM, LBG30-CM

This list contains replaceable parts used in your heater. When ordering parts, follow the instructions listed under Replacement Parts on page 51 of this manual.

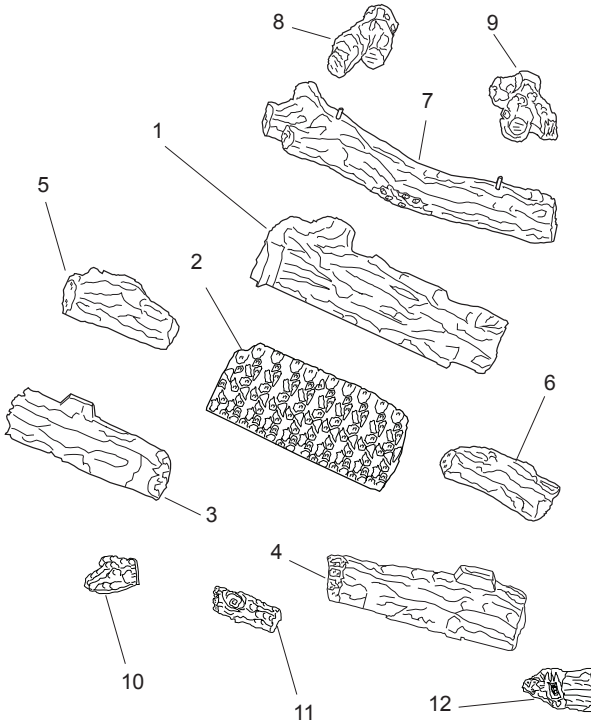

KEY	PART NUMBER				
NO.	LBG18-CM	LBG24-CM	LBG30-CM	DESCRIPTION	QTY
1	125827-01	125828-01	125828-01	Log, Rear	1
2	125827-02	125828-02	125828-02	Log, Ramp	1
3	125827-03	125828-03	125829-01	Log, Left Front	1
4	125827-04	125828-04	125829-02	Log, Right Front	1
5	125827-05	125828-05	125829-03	Log, Rear Left Top	1
6	125827-06	125828-06	125829-04	Log, Rear Right Top	1
7	125827-07	125828-07	125828-07	Log, Middle	1
8	125827-08	125828-08	125828-08	Log, Top Left	1
9	125827-09	125828-09	125828-09	Log, Top Right	1
10	125827-10	125827-10	125827-10	Log, Left Ember	1
11	125827-11	125827-11	125827-11	Log, Right Ember	1
12	125830-01	125830-01	125830-01	Log, Switch	1

PARTS

LOG MODELS

LBG18-BM, LBG24-BM, LBG30-BM

This list contains replaceable parts used in your heater. When ordering parts, follow the instructions listed under Replacement Parts on page 51 of this manual.

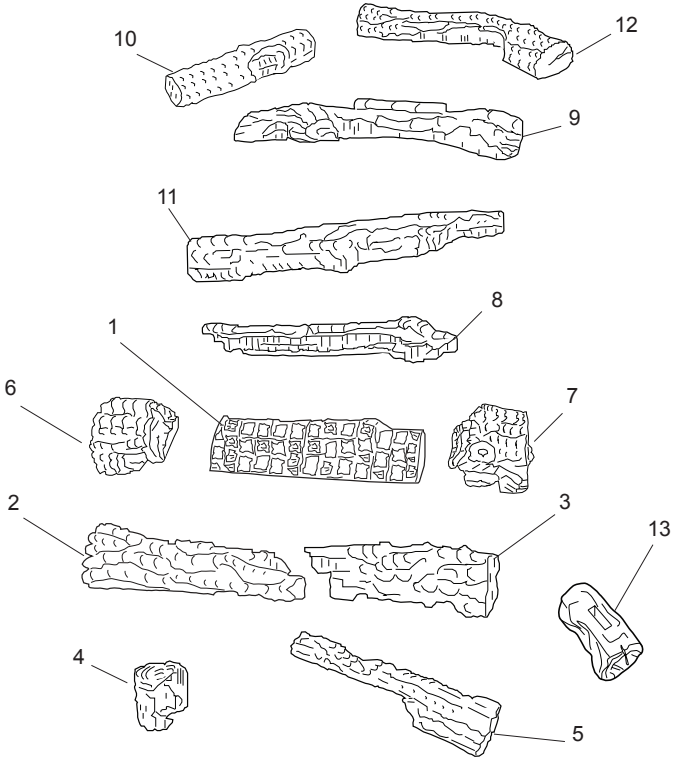

KEY NO.	PART NUMBER			DESCRIPTION	QTY
	LBG18-BM	LBG24-BM	LBG30-BM		
1	125851-01	125852-01	125852-01	Log, Ramp	1
2	125851-02	125852-02	125853-01	Log, Left Front	1
3	125851-03	125852-03	125853-02	Log, Right Front	1
4	125851-04	125852-04	125852-04	Log, Left Front Ember Bed	1
5	125851-05	125852-05	125852-05	Log, Right Front Ember Bed	1
6	125851-06	125852-06	125852-06	Log, Left Middle	1
7	125851-07	125852-07	125852-07	Log, Right Middle	1
8	125851-08	125852-08	125852-08	Log, Rear Middle	1
9	125851-09	125852-09	125852-09	Log, Rear	1
10	125851-10	125851-10	125851-10	Log, Left Top	1
11	125851-11	125852-11	125852-11	Log, Middle Crossover	1
12	125851-12	125852-12	125852-12	Log, Top Rear	1
13	125851-13	125851-13	125851-13	Log, Switch	1

SERVICE HINTS

When Gas Pressure Is Too Low

- pilot will not stay lit
- burners will have delayed ignition
- heater will not produce specified heat
- propane/LP gas supply may be low

You may feel your gas pressure is too low. If so, contact your local propane/LP or natural gas supplier.

TECHNICAL SERVICE

You may have further questions about installation, operation or troubleshooting. If so, contact FMI PRODUCTS, LLC's Technical Service Department at 1-866-328-4537. When calling please have your model and serial numbers of your heater ready.

You can also visit FMI PRODUCTS, LLC's technical services web site at www.fmiproducts.com.

REPLACEMENT PARTS

Note: Use only original replacement parts. This will protect your warranty coverage for parts replaced under warranty.

Contact authorized dealers of this product. If they can't supply original replacement part(s), call FMI PRODUCTS, LLC's Technical Service Department at 1-866-328-4537.

When calling, have ready

- your name
- your address
- model and serial numbers of your heater
- how heater was malfunctioning
- type of gas used (propane/LP or natural gas)
- purchase date

Usually, we will ask you to return the part to the factory.

ACCESSORIES

Purchase these heater accessories from your local dealer. If they can not supply these accessories, call FMI PRODUCTS, LLC at 1-866-328-4537 for referral information. You can also write to the address listed on the back page of this manual.

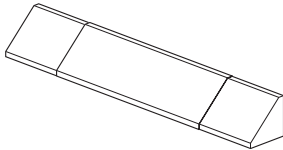

FIREPLACE HOOD

Black - GA6050

Brushed Brass - GA6053

For all models. Helps deflect heat away from mantel or wall above fireplace. Fits openings 28" to 48" wide.

LAVA ROCK - GA6060

For all models. Order when additional rock is desired.

VENT-FREE LOGMATE® FIREBOXES

Available in 32", 36" and 42" models. Circulating fireboxes feature louvers and an optional blower. Non-circulating, smooth face models are ideal for custom trim applications such as stone or marble.

VFB32C (CIRCULATING), VFB32NC (NON-CIRCULATING) SERIES FIREBOXES

For 18" and 24" log models.

VFB36C1, VFB42C1 SERIES (CIRCULATING)

VFB36NC1, VFB42NC1 SERIES FIREBOXES (NON-CIRCULATING)

For all log models.

FLOOR MEDIA KIT - FM100

For all models. Includes lava rock, burner embers, and burner cinders

CONTROL COVER KIT - CC100

For all models. Includes control cover log and 6 unique fall-away logs.

WARRANTY

KEEP THIS WARRANTY

Model (located on product or identification tag) _____

Serial No. (located on product or identification tag) _____

Date Purchased _____

Keep receipt for warranty verification.

FMI PRODUCTS, LLC LIMITED WARRANTIES

New Products

Standard Warranty: FMI PRODUCTS, LLC warrants this new product and any parts thereof to be free from defects in material and workmanship for a period of four (4) years from the date of first purchase from an authorized dealer provided the product has been installed, maintained and operated in accordance with FMI PRODUCTS, LLC's warnings and instructions.

For products purchased for commercial, industrial or rental usage, this warranty is limited to 90 days from the date of first purchase.

Factory Reconditioned Products

Limited Warranty: FMI PRODUCTS, LLC warrants factory reconditioned products and any parts thereof to be free from defects in material and workmanship for 30 days from the date of first purchase from an authorized dealer provided the product has been installed, maintained and operated in accordance with FMI PRODUCTS, LLC's warnings and instructions.

Terms Common to All Warranties

The following terms apply to all of the above warranties:

Always specify model number and serial number when contacting the manufacturer. To make a claim under this warranty the bill of sale or other proof of purchase must be presented.

This warranty is extended only to the original retail purchaser when purchased from an authorized dealer, and only when installed by a qualified installer in accordance with all local codes and instructions furnished with this product.

This warranty covers the cost of part(s) required to restore this product to proper operating condition and an allowance for labor when provided by a FMI PRODUCTS, LLC Authorized Service Center or a provider approved by FMI PRODUCTS, LLC. Warranty parts must be obtained through authorized dealers of this product and/or FMI PRODUCTS, LLC who will provide original factory replacement parts. Failure to use original factory replacement parts voids this warranty.

Travel, handling, transportation, diagnostic, material, labor and incidental costs associated with warranty repairs, unless expressly covered by this warranty, are not reimbursable under this warranty and are the responsibility of the owner.

Excluded from this warranty are products or parts that fail or become damaged due to misuse, accidents, improper installation, lack of proper maintenance, tampering, or alteration(s).

This is FMI PRODUCTS, LLC's exclusive warranty, and to the full extent allowed by law; this express warranty excludes any and all other warranties, express or implied, written or verbal and limits the duration of any and all implied warranties, including warranties of merchantability and fitness for a particular purpose to four (4) years on new products and 30 days on factory reconditioned products from the date of first purchase. FMI PRODUCTS, LLC makes no other warranties regarding this product.

FMI PRODUCTS, LLC's liability is limited to the purchase price of the product, and FMI PRODUCTS, LLC shall not be liable for any other damages whatsoever under any circumstances including indirect, incidental, or consequential damages.

Some states do not allow limitations on how long an implied warranty lasts or the exclusion or limitation of incidental or consequential damages, so the above limitation or exclusion may not apply to you.

This warranty gives you specific legal rights, and you may also have other rights which vary from state to state.

For information about this warranty contact:

FMI PRODUCTS, LLC
2701 S. Harbor Blvd.
Santa Ana, CA 92704
www.fmiproducts.com
1-866-328-4537

125784-01
Rev. C
01/12