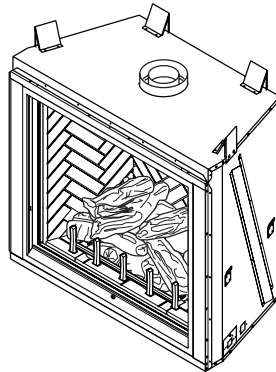




FMI PRODUCTS, LLC

**DIRECT-VENT FIREPLACE**

**OWNER'S OPERATION AND INSTALLATION MANUAL**



**NATIONAL FIREPLACE INSTITUTE**  
**NFI**  
**CERTIFIED**  
[www.nficertified.org](http://www.nficertified.org)

We recommend that our gas hearth products be installed and serviced by professionals who are certified in the U.S. by the National Fireplace Institute® (NFI) as NFI Gas Specialists.

**MODELS (V)DVF36NS, (V)DVF36PS, (V)DVF36NH, (V)DVF36PH, DVF36NS-HA, DVF36NH-HA, (V)DVF42NS, (V)DVF42PS, (V)DVF42NH, (V)DVF42PH, DVF42NS-HA, AND DVF42NH-HA**

**⚠ WARNING:** If the information in this manual is not followed exactly, a fire or explosion may result causing property damage, personal injury or loss of life.

- Do not store or use gasoline or other flammable vapors and liquids in the vicinity of this or any other appliance.
- **WHAT TO DO IF YOU SMELL GAS**
  - Do not try to light any appliance.
  - Do not touch any electrical switch; do not use any phone in your building.
  - Immediately call your gas supplier from a neighbor's phone. Follow the gas supplier's instructions.
  - If you cannot reach your gas supplier, call the fire department.
- Installation and service must be performed by a qualified installer, service agency or the gas supplier.

**INSTALLER:** Leave this manual with the appliance  
**CONSUMER:** Retain this manual for future reference.

## TABLE OF CONTENTS

Safety .....	2	Inspecting Burners.....	26
Local Codes.....	4	Cleaning and Maintenance.....	27
Product Identification.....	5	Troubleshooting.....	29
Product Features.....	5	Parts .....	32
Pre-installation.....	6	Specifications .....	38
Location of Termination Cap.....	8	Wiring Diagram.....	38
Requirements for the Commonwealth of Massachusetts.....	9	Replacement Parts.....	39
Venting Installation .....	10	Technical Service.....	39
Fireplace Installation.....	18	Service Hints .....	39
Operation.....	25	Accessories.....	39
		Warranty.....	Back Cover

## SAFETY

**⚠ WARNING:** Improper installation, adjustment, alteration, service or maintenance can cause injury or property damage. Refer to this manual for correct installation and operational procedures. For assistance or additional information consult a qualified installer, service agency or the gas supplier.

This appliance is only for use with the type of gas indicated on the rating plate. This appliance is not convertible for use with other gases, unless a certified kit is used.

**State of Massachusetts:** The installation must be made by a licensed plumber or gas fitter in the Commonwealth of Massachusetts.

**⚠ WARNING:** This product contains and/or generates chemicals known to the State of California to cause cancer or birth defects or other reproductive harm.

**IMPORTANT:** Read this owner's manual carefully and completely before trying to assemble, operate or service this fireplace. Improper use of this fireplace can cause serious injury or death from burns, fire, explosion, electrical shock and carbon monoxide poisoning.

**⚠ DANGER:** Carbon monoxide poisoning may lead to death!

This vented gas fireplace is a sealed combustion gas fireplace designed for residential applications. This fireplace must be installed with FMI PRODUCTS, LLC vent pipe components and terminations.

This fireplace complies with the *National Safety Standards* and is listed and tested by *PFS Corporation to ANSI Z21.50* standard as vented gas fireplace.

This fireplace must be installed by a qualified (certified or licensed) service person. It brings in fresh air for combustion through the outer pipe and combustion gases are exhausted through the inner pipe. If the glass door assembly and venting pipe are not properly sealed, connected and sealed, carbon monoxide leakage (spillage) can occur.

**Carbon Monoxide Poisoning:** Early signs of carbon monoxide poisoning resemble the flu, with headaches, dizziness or nausea. If you have these signs, the fireplace may not be working properly. **Get fresh air at once!** Have fireplace serviced. Some people are more affected by carbon monoxide than others. These include pregnant women, people with heart or lung disease or anemia, those under the influence of alcohol and those at high altitudes.

## SAFETY

### Continued

**Natural and Propane/LP Gas:** Natural and propane/LP gas are odorless. An odor-making agent is added to the gas. The odor helps you detect a gas leak. However, the odor added to the gas can fade. Gas may be present even though no odor exists.

Make certain you read and understand all warnings. Keep this manual for reference. It is your guide to safe and proper operation of this fireplace.

**⚠ WARNING:** Any change to this fireplace or its controls can be dangerous. Do not modify this fireplace under any circumstances. Any parts removed for servicing must be replaced prior to operating fireplace.

**⚠ WARNING:** Do not use a blower insert, heat exchanger insert or other accessory not approved for use with this fireplace.

**⚠ WARNING:** This appliance is only for use with the type of gas indicated on the rating plate. This appliance is not convertible for use with other gases unless a certified kit is used.

**⚠ WARNING:** Do not allow fans to blow directly into the fireplace. Avoid any drafts that alter burner flame patterns.

Due to high temperatures, the appliance should be located out of traffic and away from furniture and draperies.

Do not place clothing or other flammable material on or near the appliance. Never place any objects on the appliance.

Do not use this fireplace to cook food or burn paper or other flammable material.

This fireplace reaches high temperatures. Keep children and adults away from hot surface to avoid burns or clothing ignition. Fireplace will remain hot for a time after shutdown. Allow surface to cool before touching.

**⚠ WARNING**



**HOT GLASS WILL CAUSE BURNS.**  
**DO NOT TOUCH GLASS UNTIL COOLED.**  
**NEVER ALLOW CHILDREN TO TOUCH GLASS.**

# SAFETY

## Continued

**Carefully supervise young children when they are in the room with fireplace.**

**Keep the area around your fireplace clear of combustible materials, gasoline and other flammable vapor or liquids. Do not run fireplace where these are used or stored.**

1. For propane/LP fireplace, do not place propane/LP supply tank(s) inside any structure. Locate propane/LP supply tank(s) outdoors. To prevent performance problems, do not use propane/LP fuel tank of less than 100 lb. capacity.
2. If you smell gas
  - shut off gas supply
  - do not try to light any appliance
  - do not touch any electrical switch; do not use any phone in your building
  - immediately call your gas supplier from a neighbor's phone. Follow the gas supplier's instructions
  - if you cannot reach you gas supplier, call the fire department.
3. Never install the fireplace
  - in a recreational vehicle
  - in windy or drafty areas where curtains or other combustible (flammable) objects can make contact with the fireplace front
  - in high traffic areas
4. Turn fireplace off and let cool before servicing, installing or repairing. Only a qualified service person should install, service or repair this fireplace. Have fireplace inspected annually by a qualified service person.
5. You must keep control compartments, burners and circulating air passages clean. More frequent cleaning may be needed due to excessive lint and dust from carpeting, bedding material, etc. Turn off the gas valve and pilot light before cleaning fireplace.
6. Have venting system inspected annually by a qualified service person. If needed, have venting system cleaned or repaired.

See *Cleaning and Maintenance*, page 27.

7. Do not use any solid fuels (wood, coal, paper, cardboard, etc.) in this fireplace. Use only the gas type indicated on fireplace nameplate.
8. This appliance, when installed, must be electrically grounded in accordance with local codes or, in the absence of local codes, with the *National Electrical Code, ANSI/NFPA 70*.
9. Do not use fireplace if any part has been exposed to or under water. Immediately call a qualified service person to arrange for replacement of the unit.
10. Do not operate fireplace if any log is broken.
11. Do not operate fireplace with glass door removed, cracked or broken.
12. Provide adequate clearances around air openings.

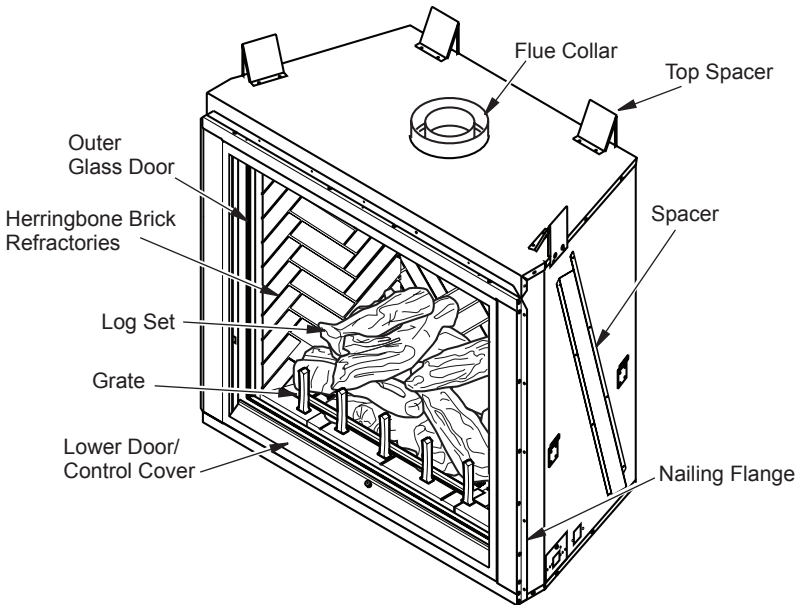
## LOCAL CODES

Install and use fireplace with care. Follow all local codes. In the absence to local codes, use the current *National Fuel Gas Code ANSI Z223.1/NFPA 54\**.

\*Available from:

American National Standards Institute, Inc.  
1430 Broadway  
New York, NY 10018  
National Fire Protection Association, Inc.  
Batterymarch Park  
Quincy, MA 02269

## PRODUCT IDENTIFICATION



*Figure 1 - Direct Vent Fireplace*

## PRODUCT FEATURES

These are a few facts that can help you understand and enjoy your direct vent fireplace:

- The venting system may be routed to the outside of your home in several ways. It may vent through the roof (vertical) or it may vent to an outside/exterior wall (horizontal). The vent pipe installation is very important to allow for proper operation. You must follow the venting instructions very carefully for either vertical or horizontal applications.
- This fireplace may be installed in any room of your house provided all local codes and these installation instructions are followed.
- Each time you turn on your fireplace, you may notice some amount of condensation on the inside of the fireplace glass. This is normal and will disappear after 10-20 minutes of operation.
- Your direct vent gas fireplace system (fireplace and venting) is a balanced and sealed gas operating unit. It requires approximately 10-20 minutes of operating time before the flame pattern stabilizes.

# PRE-INSTALLATION

## LOCATION AND SPACE REQUIREMENTS

Determine the safest and most efficient location for your direct vent fireplace. Make sure that rafters and wall studs are not in the way of the venting system. Choose a location where the heat output is not affected by drafts, air conditioning ducts, windows or doors. Figure 2 shows some common locations. Be aware of all restrictions and precautions before deciding the exact location for your fireplace and termination cap.

When deciding the location of your fireplace, follow these rules:

- Do not connect this fireplace venting to a chimney flue serving a separate solid-fuel burning fireplace or appliance.
- Due to high temperatures, do not locate this fireplace in high traffic areas, windy or drafty areas or near furniture or draperies.
- Proper clearances must be maintained.
- If your fireplace is to be installed directly on carpeting, vinyl tile or any combustible material other than wood, it must be installed on a metal or wood panel extending the full width and depth of the fireplace (see Figure 3).
- Your fireplace is designed to be used in zero clearance installations. Wall or framing material can be placed directly against any exterior surface on back, sides or top of your fireplace, except where standoff spacers are integrally attached. If standoff spacers are attached to your fireplace, these spacers can be placed directly against wall or framing material. See framing details, page 7.
- When locating termination cap, it is important to observe the minimum clearances shown in Figure 8, page 8.
- If recessing into a wall, you can avoid extra framing by positioning your fireplace against an already existing framing member.
- Do not recess termination cap into a wall or siding.
- You may paint the termination cap with 450° F (232° C) heat-resistant paint to coordinate with the exterior finish.
- There must not be any obstruction such as bushes, garden sheds, fences, decks or utility buildings within 24" from the front of the termination cap and the front of outside air vent.
- Do not locate termination cap and outside air vent where excessive snow or ice build up may occur. Be sure to clear vent termination area after snow falls to prevent

accidental blockage of venting system. When using snow blowers, do not direct snow towards vent termination area.

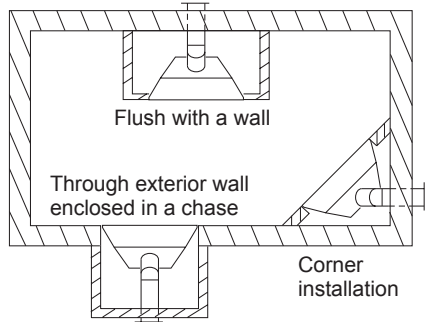


Figure 2 - Common Fireplace Locations

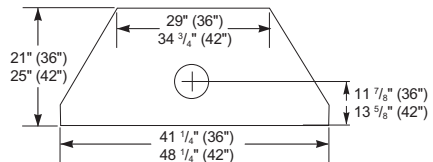


Figure 3 - Fireplace Top Dimensions

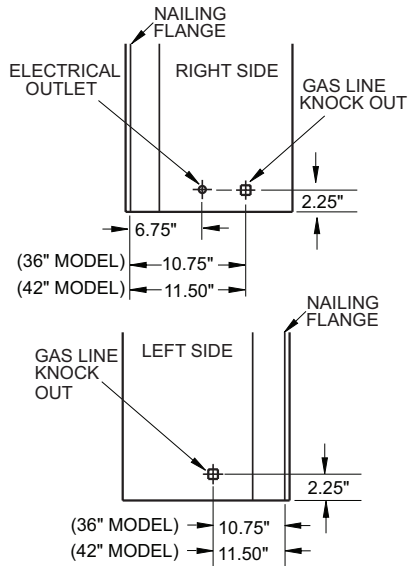


Figure 4 - Electrical Outlet and Gas Knockout Locations

# PRE-INSTALLATION

Continued

## CLEARANCES

Minimum clearances to combustibles for the fireplace are as follows:

*Back and sides	1"
Perpendicular walls	6"
Floor	0"
Ceiling to louver opening	42"
Front	36"
Top of Standoffs	0"
Vent	(See venting instructions for specific venting clearances.)

Combustible material with a maximum thickness of 5/8" may be flush with the top front of fireplace.

\* For back and sides of fireplace, do not pack with insulation or other materials. 1" clearance not required at nailing flanges.

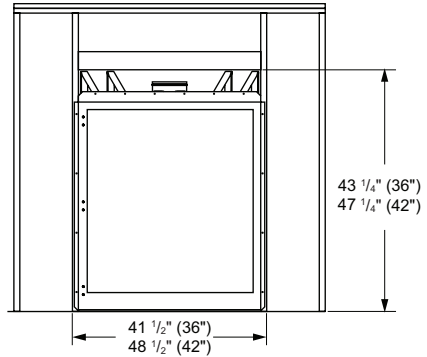
**NOTICE: This fireplace is intended for use as supplemental heat. Use this fireplace along with your primary heating system. Do not install this fireplace as your primary heat source. If you have a central heating system, you may run system's circulating blower while using fireplace. This will help circulate the heat throughout the house.**

## FRAMING AND FINISHING

Figure 5 shows typical framing of this fireplace. Figure 6 shows framing for corner installation. All minimum clearances must be met.

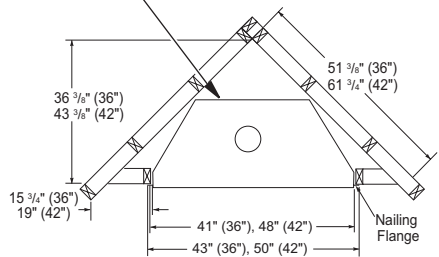
If you are using a separate combustible mantel piece, refer to Figure 7 for proper installation height. You can install noncombustible mantels at any height above the fireplace.

*Note: Noncombustible mantels may discolor!*

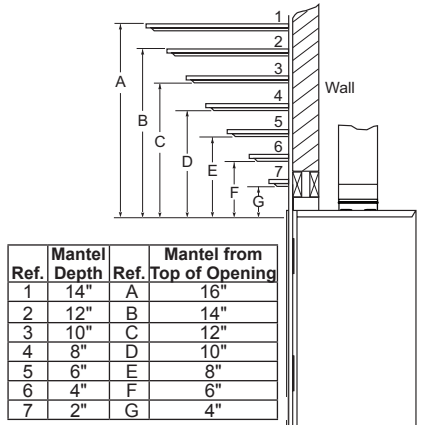


**Figure 5 - Framing Clearances with Outside Air Flex Duct**

Maintain 1" Clearance at Sides and Back of Fireplace

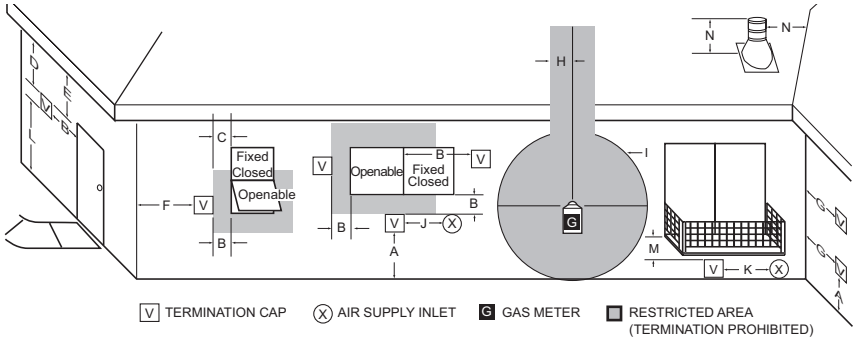


**Figure 6 - Framing Clearances for Corner Installation**



**Figure 7 - Clearances for Combustible Mantels**

# LOCATION OF TERMINATION CAP



V TERMINATION CAP   
 X AIR SUPPLY INLET   
 G GAS METER   
  RESTRICTED AREA (TERMINATION PROHIBITED)

- |  |  |
|--|--|
| <p>A = clearance above grade, veranda, porch, deck, or balcony [*12" (30.5 cm) minimum]</p> <p>B = clearance to window or door that may be opened [6" (15 cm) min. for 10,000 Btu or less; 9" (23 cm) in US if between 10,000 and 50,000, 12" (30 cm) in Canada if between 10,000 and 100,000; 12" (30 cm) in US if greater than 50,000, 36" (91 cm) in Canada if greater than 100,000]</p> <p>C = clearance to permanently closed window [minimum 12" (30.5 cm) recommended to prevent condensation on window]</p> <p>D = vertical clearance to ventilated soffit located above the terminal within a horizontal distance of 24" (61 cm) from the center-line of the terminal [18" (45.7 cm) minimum]</p> <p>E = clearance to unventilated soffit [12" (30.5 cm) minimum]</p> <p>F = clearance to outside corner (see below)</p> <p>G = clearance to inside corner (see below)</p> <p>H = *not to be installed above a meter/regulator assembly within 36" (91.4 cm) horizontally from the center line of the regulator</p> | <p>I = clearance to service regulator vent outlet [*72" (182.9 cm) minimum]</p> <p>J = clearance to non-mechanical air supply inlet to building or the combustion air inlet to any other fireplace [6" (15 cm) min. for 10,000 Btu or less; 9" (23 cm) in US if between 10,000 and 50,000, 12" (30 cm) in Canada if between 10,000 and 100,000; 12" (30 cm) in US if greater than 50,000, 36" (91 cm) in Canada if greater than 100,000]</p> <p>K = clearance to a mechanical air supply inlet [*In Canada, 6 ft. (1.83m) minimum; In US 3 ft. (91 cm) above if within 10 ft. (3 m) horizontally]</p> <p>L = † clearance above paved side-walk or a paved driveway located on public property [*84" (213.3 cm) minimum]</p> <p>M = clearance under veranda, porch, deck [*12" (30.5 cm) minimum ‡]</p> <p>N = clearance above a roof shall extend a minimum of 24" (61 cm) above the highest point when it passes through the roof surface and any other obstruction within a horizontal distance of 18" (45.7 cm)</p> |
|--|--|

† vent shall not terminate directly above a side-walk or paved driveway which is located between two

single family dwellings and serves both dwellings\*

‡ only permitted if veranda, porch, deck or balcony is fully open on a minimum of 2 sides beneath the floor\*

\* as specified in CAN/CSA B149 (.1 or .2) Installation Codes (1991) for Canada and U.S.A.

Note: Local codes or regulations may require different clearances

## Termination Clearances for Buildings with Combustible and Noncombustible Exteriors

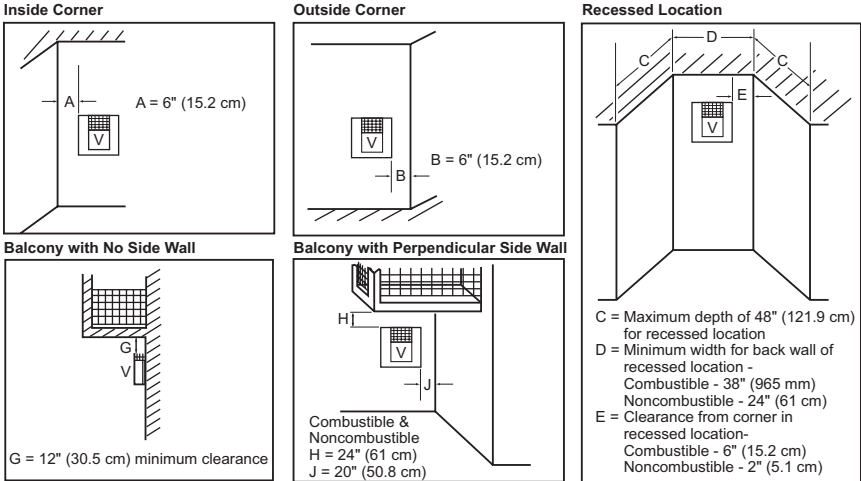


Figure 8 - Minimum Clearances for Termination Cap

# REQUIREMENTS FOR THE COMMONWEALTH OF MASSACHUSETTS

For all side wall horizontally vented gas fueled equipment installed in every dwelling, building or structure used in whole or in part for residential purposes, including those owned or operated by the Commonwealth and where the side wall exhaust vent termination is less than seven (7) feet above finished grade in the area of the venting, including but not limited to decks and porches, the following requirements shall be satisfied:

## INSTALLATION OF CARBON MONOXIDE DETECTORS

At the time of installation of the side wall horizontally vented gas fueled equipment, the installing plumber or gasfitter shall observe that a hard wired carbon monoxide detector with an alarm and battery backup is installed on the floor level where the gas equipment is to be installed. In addition, the installing plumber or gasfitter shall observe that a battery operated or hard wired carbon monoxide detector with an alarm is installed on each additional level of the dwelling, building or structure served by the side wall horizontal vented gas fueled equipment. It shall be the responsibility of the property owner to secure the services of qualified licensed professionals for the installation of hard wired carbon monoxide detectors.

In the event that the side wall horizontally vented gas fueled equipment is installed in a crawl space or an attic, the hard wired carbon monoxide detector with alarm and battery back-up may be installed on the next adjacent floor level.

In the event that the requirements of this subdivision can not be met at the time of completion of installation, the owner shall have a period of thirty (30) days to comply with the above requirements; provided, however, that during said thirty (30) day period, a battery operated carbon monoxide detector with an alarm shall be installed.

### Approved Carbon Monoxide Detectors

Each carbon monoxide detector as required in accordance with the above provisions shall comply with NFPA 720 and be ANSI/UL 2034 listed and IAS certified.

## SIGNAGE

A metal or plastic identification plate shall be permanently mounted to the exterior of the building at a minimum height of eight (8) feet above grade directly in line with the exhaust vent terminal for the horizontally vented gas fueled heating appliance or equipment. The sign shall read, in print size no less than 1/2" in size, "GAS VENT DIRECTLY BELOW. KEEP CLEAR OF ALL OBSTRUCTIONS".

## INSPECTION

The state or local gas inspector of the side wall horizontally vented gas fueled equipment shall not approve the installation unless, upon inspection, the inspector observes carbon monoxide detectors and signage installed in accordance with the provisions of 248 CMR 5.08(2)(a) 1 through 4.

EXEMPTIONS: The following equipment is exempt from 248 CMR 5.08(2)(a) 1 through 4:

- The equipment listed in Chapter 10 entitled "Equipment Not Required To Be Vented" in the most current edition of NFPA 54 as adopted by the Board; and
- Product Approved side wall horizontally vented gas fueled equipment installed in a room or structure separate from the dwelling, building or structure used in whole or in part for residential purposes.

## MANUFACTURER REQUIREMENTS

### Gas Equipment Venting System Provided

When the manufacturer of Product Approved side wall horizontally vented gas equipment provides a venting system design or venting system components with the equipment, the instructions provided by the manufacturer for installation of the equipment and the venting system shall include:

- Detailed instructions for the installation of the venting system design or the venting system components; and
- A complete parts list for the venting system design or venting system.

### Gas Equipment Venting System Not Provided

When the manufacturer of a Product Approved side wall horizontally vented gas fueled equipment does not provide the parts for venting the flue gases, but identifies "special venting systems", the following requirements shall be satisfied by the manufacturer:

- The referenced "special venting system" instructions shall be included with the appliance or equipment installation instructions; and
- The "special venting systems" shall be Product Approved by the Board, and the instructions for that system shall include a parts list and detailed installation instructions.

A copy of all installation instructions for all Product Approved side wall horizontally vented gas fueled equipment, all venting instructions, all parts lists for venting instructions, and/or all venting design instructions shall remain with the appliance or equipment at the completion of the installation.

## VENTING INSTALLATION

**NOTICE: Read these instructions completely before attempting installation.**

These models are tested and approved for use with FMI PRODUCTS, LLC (direct vent) pipe components and terminations.

The venting system must terminate on the outside of the structure and can not be attached to a chimney or flue system serving a separate solid fuel or gas burning appliance. A direct vent appliance must have its own venting system. DO NOT common vent this appliance.

These models are approved to be vented either horizontally through an outside wall or vertically through a roof or chase enclosure using the following guidelines:

- When venting system terminates horizontally on an outside wall, you may install a standoff if the termination cap is to be installed directly on a combustible finish such as vinyl, wood, stucco, etc.
- Never run the vent downward as this may cause excessive temperatures which could cause a fire.
- Vent pipe air space clearances to combustibles are 1" on all sides except on the horizontal sections, which requires 2" clearance from the top of the pipe. Where the termination cap penetrates a combustible wall, 1" air space clearance is required.
- Have fireplace and selected vent components on hand to help determine the exact measurements when elbowing or offsetting. Always use wall firestops when penetrating walls and firestops when penetrating ceilings or attic spaces.
- For installation of fireplace at elevations of 4000 feet or greater, pay special attention to venting requirement recommendations.

**⚠ WARNING: Read all instructions completely and thoroughly before attempting installation. Failure to do so could result in serious injury, property damage or loss of life.**

**NOTICE: Failure to follow these instructions will void the warranty.**

**NOTICE: Do not seal termination cap to vent pipe. Cap must be removable for vent inspection and maintenance.**

### INSTALLATION PRECAUTIONS

- Wear gloves and safety glasses for protection
- Use extreme caution when using ladders or when on roof tops
- Be aware of electrical wiring locations in walls and ceilings

The following actions will void the warranty on your venting system:

- Installation of any damaged venting component
- Unauthorized modification of the venting system (Do not cut or alter vent components)
- Installation of any component part not manufactured or approved by FMI PRODUCTS, LLC
- Installation other than as instructed by these instructions

**⚠ WARNING: This gas fireplace and vent assembly must be vented directly to the outside. The venting system must NEVER be attached to a chimney serving a separate solid fuel burning appliance. Each direct vent gas appliance must use a separate vent system. Do not use common vent systems.**

**⚠ WARNING: Vent pipe air space clearances to combustibles are 1" on all sides except on the horizontal sections, which require 2" clearances from the top of the pipe. Where the termination cap penetrates a combustible wall, 1" air space clearance is required.**

# VENTING INSTALLATION

Continued

## INSTALLATION PLANNING

There are two basic types of direct vent installation:

- Horizontal Termination
- Vertical Termination

### Horizontal Termination Installation

**IMPORTANT:** Horizontal square terminations require only inner portion of wall firestop. Horizontal installations using round termination require exterior portion of wall firestop.

1. Set fireplace in its desired location and determine the route your horizontal venting will take. Do not secure fireplace until all venting has been installed. Some installations require sliding fireplace in and out of position to make final venting connections. Figures 15 and 16 on pages 13 and 14, show different configurations for venting with horizontal termination that will help you decide which application best suits your installation. Check to see if wall studs or roof rafters are in the path of your desired venting route. If they are, you may want to adjust location of fireplace.

2. Direct vent pipe sections and components are designed with special twist-lock connections.

**Twist-Lock Procedure:** Female ends of pipes have locking lugs (indentations). These lugs will slide straight into matching slots on male ends of adjacent pipes. Push pipe sections together and twist one section clockwise approximately one-quarter turn until sections are fully locked (see Figure 9).

*Note: Horizontal runs of vent must be supported every three feet. Use wall straps for this purpose.*

3. Assemble desired combination of pipe and elbows to fireplace flue collar. If there are long portions of venting run, pre-assembled pipe sections may be installed as subassemblies for convenience.
4. Carefully determine location where vent pipe assembly will penetrate outside wall. Center of hole should line up with center line of horizontal vent pipe. Mark wall for an 11 1/2" x 11 1/2" square hole. Cut and frame square hole in exterior wall where vent will be terminated. If wall being pen-

etrated is constructed of noncombustible material, such as masonry block or concrete, a 8 1/2" hole with zero clearance is acceptable (see Figure 9).

**WARNING:** Do not recess vent termination into any wall. This will cause a fire hazard.

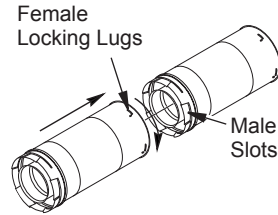


Figure 9 - Vent Pipe Connections

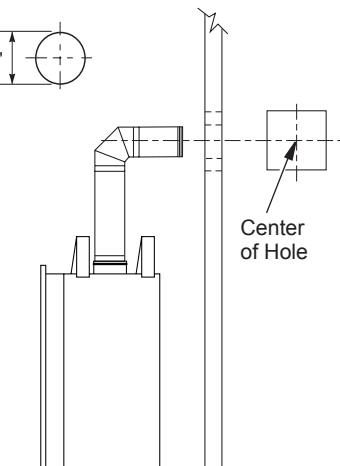
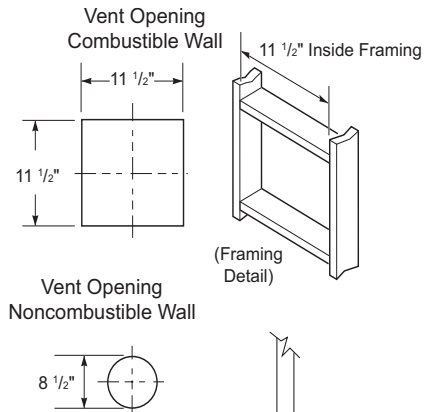


Figure 10 - Vent Opening Requirements

# VENTING INSTALLATION

*Continued*

5. **Noncombustible Exterior Wall:** Position horizontal vent cap in center of the 8 1/2" round hole and attach to exterior wall with four wood screws provided. Before attaching vent cap to exterior wall, run a bead of non-hardening mastic (pliable sealant) around outside edges of standoff to make a seal between it and outside wall.

*Note: Four wood screws provided should be replaced with appropriate fasteners for stucco, brick, concrete or other types of sidings (see Figure 11).*

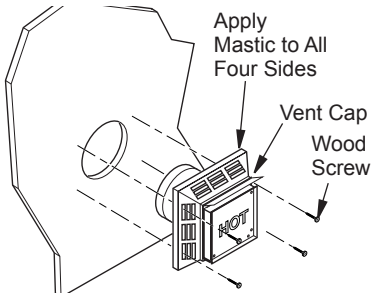
**Combustible Exterior Wall:** For vinyl siding, stucco or wood exteriors, a siding standoff may be installed between vent cap and exterior wall. Siding standoff prevents excessive heat from damaging siding materials. Siding material must be cut to accommodate standoff. Bolt vent cap to standoff. Apply non-hardening mastic around outside edge of standoff. Position standoff/cap assembly in the center of 11 1/2" square hole and attach to exterior wall with provided wood screws (see Figure 12). Siding standoff must sit flush against exterior fascia material.

6. **Connecting Vent Cap with Horizontal Vent Pipe:** Slide wall firestop over vent pipe before connecting horizontal run to vent cap (see Figure 13).

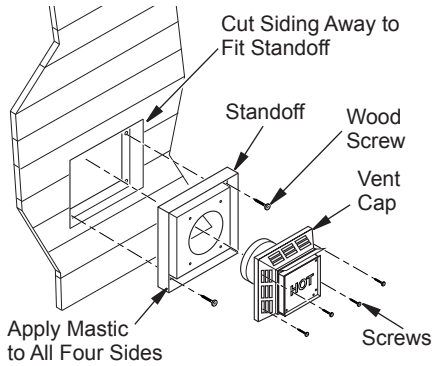
Carefully move fireplace, with vent assembly attached, toward wall and insert vent pipe into horizontal termination. Pipe overlap should be a minimum of 1 1/4" (see Figure 14).

Slide wall firestop against interior wall surface and attach with screws provided. See Figure 14, for horizontal termination details.

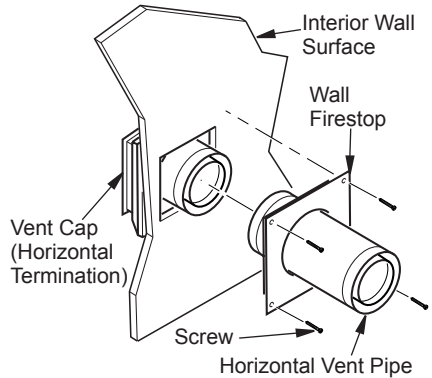
Place fireplace into position and shim with noncombustible material if needed. Nail or screw side flanges to framing to secure unit in place. **IMPORTANT:** Make sure fireplace is level before securing. If fireplace is not level it will not work properly.



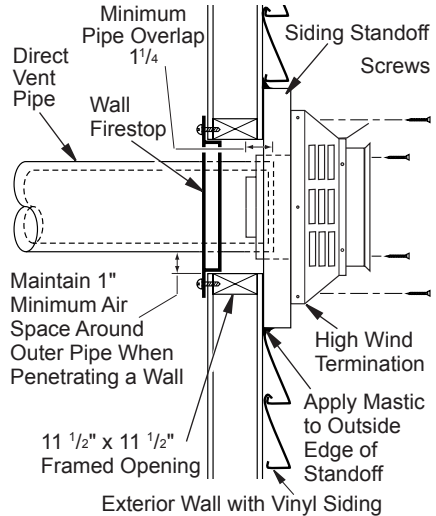
**Figure 11 - Installing Horizontal Vent Cap (Noncombustible Exterior)**



**Figure 12 - Installing Siding Standoff (Combustible Exterior Wall)**



**Figure 13 - Connecting Vent Cap with Horizontal Vent Pipe**



**Figure 14 - Typical Horizontal Termination Cap Mounting with Additional Siding Standoff Installed**

# VENTING INSTALLATION

*Continued*

## Horizontal Termination Configurations

Figure 15 shows a configuration for venting with horizontal termination with a chart of critical minimum and maximum dimensions which MUST be met.

Figure 16, page 14, shows a configuration for venting with horizontal termination using two 90° elbows with a chart of critical minimum and maximum dimensions which MUST be met.

If using a venting configuration of only horizontal venting with no vertical run, a ¼" rise for every 12" of run toward the termination is required.

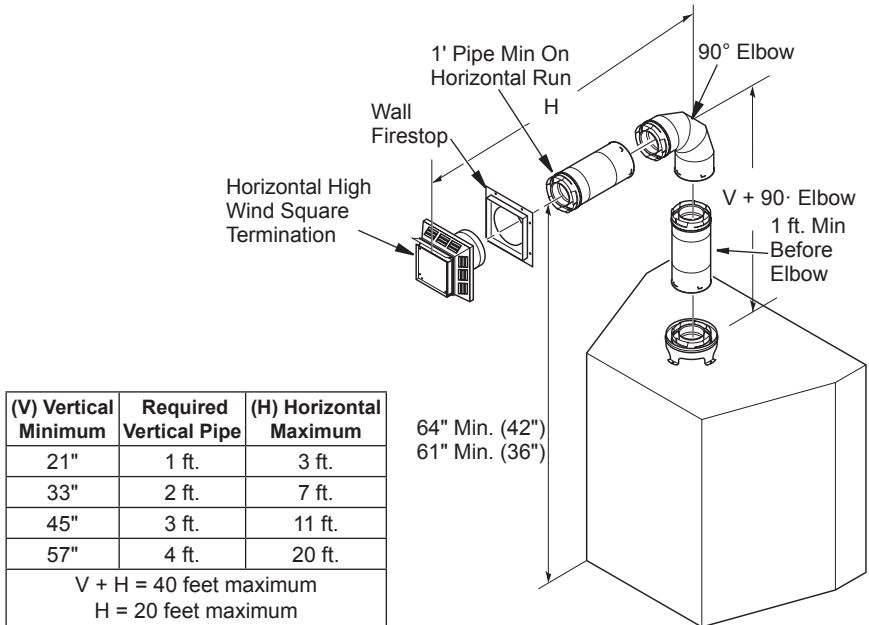
**NOTICE: Do not seal termination cap to vent pipe. Cap must be removable for vent inspection and maintenance.**

**⚠ WARNING: Never run vent downward as this may cause excessive temperatures which could cause a fire. Operation of improperly installed and maintained venting system could result in serious injury, property damage or loss of life.**

## GROUND FLOOR INSTALLATION

Recommended Applications:

- Through the wall using round or square termination
- NOT FOR CORNER INSTALLATION



**Figure 15 - Horizontal Termination Using One 90° Elbow**

# VENTING INSTALLATION

Continued

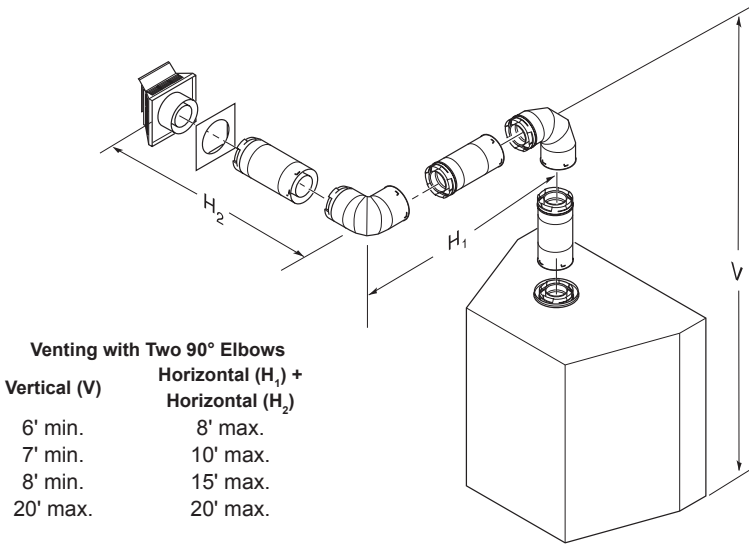


Figure 16 - Horizontal Termination Using Two 90° Elbows

## Vertical Termination Installation

**Note:** Vertical restrictor must be installed in all vertical installations.

1. Determine route your vertical venting will take. If ceiling joists, roof rafters or other framing will obstruct venting system, consider an offset (see Figure 17) to avoid cutting load bearing members. *Note: Pay special attention to these installation instructions for required clearances (air space) to combustibles when passing through ceilings, walls, roofs, enclosures, attic rafters, etc. Do not pack air spaces with insulation. Also note maximum vertical rise of venting system and any maximum horizontal offset limitations.*
2. Set fireplace in desired location. Drop a plumb line down from ceiling to position of fireplace exit flue. Mark center point where vent will penetrate ceiling. Drill a small locating hole at this point.
3. Drop a plumb line from inside of roof to locating hole in ceiling. Mark center point where vent will penetrate roof. Drill a small locating hole at this point.

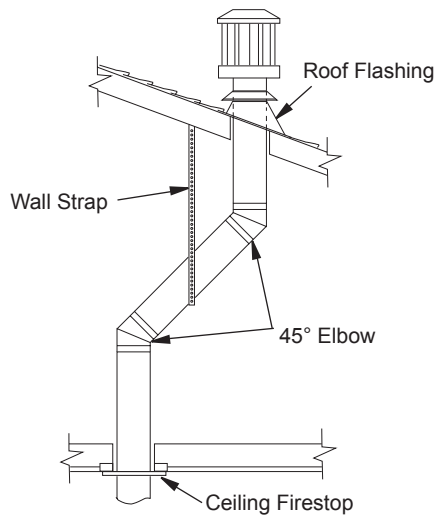


Figure 17 - Offset with Wall Strap and 45° Elbows

# VENTING INSTALLATION

Continued

## Flat Ceiling Installation

1. Cut a 11 1/2" square hole in ceiling using locating hole as a center point. Opening should be framed to 11 1/2" x 11 1/2" inside dimensions, as shown in Figure 10 on page 11 using framing lumber the same size as ceiling joists. If area above ceiling is an insulated ceiling or an attic, nail firestop from top side. This prevents loose insulation from falling into required clearance space. If area above ceiling is a living space, install firestop below framed hole. Firestop should be installed with no less than three nails per side (see Figure 15).
2. Assemble desired lengths of pipe and elbows necessary to reach from fireplace flue up through firestop. Be sure all pipe and elbow connections are fully twist-locked (see Figure 9, page 11).
3. Cut a hole in the roof using locating hole as a center point. (Cover any exposed open vent pipes before cutting hole in roof.) The 11 1/2" x 11 1/2" hole must be measured on the horizontal; actual length may be larger depending on pitch of roof. There must be a 1" clearance from vent pipe to combustible materials. Frame opening as shown in Figure 10, page 11.
4. Connect a section of pipe and extend up through hole.

*Note: If an offset is needed to avoid obstructions, you must support vent pipe every 3 feet. Use wall straps for this purpose (see Figure 17). Whenever possible, use 45° elbows instead of 90° elbows. The 45° elbow offers less restriction to the flow of flue gases.*

5. Place flashing over pipe section(s) extending through roof. Secure base of flashing to roof and framing with roofing nails. Be sure roofing material overlaps top edge of flashing as shown in Figure 17. There must be a 1" clearance from vent pipe to combustible materials.
6. Continue to add pipe sections until height of vent cap meets the minimum building code requirements described in Figure 8 on page 8.

*Note: You must increase vent height for steep roof pitches. Nearby trees, adjoining rooflines, steep pitched roofs and other similar factors may cause poor draft or*

*down-drafting in high winds. Increasing vent height may solve this problem.*

7. Twist-lock vent cap onto last section of vent pipe.

## Vent Termination Chart

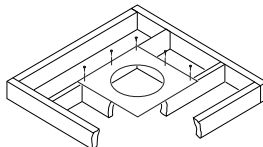
Roof Pitch	Minimum Height Feet Min.
Flat to 6/12	1
6/12 to 7/12	1.25
Over 7/12 to 8/12	1.5
Over 8/12 to 9/12	2
Over 9/12 to 10/12	2.5
Over 10/12 to 11/12	3.25
Over 11/12 to 12/12	4
Over 12/12 to 14/12	5
Over 14/12 to 16/12	6
Over 16/12 to 18/12	7
Over 18/12 to 20/12	7.5
Over 20/12 to 21/12	8.0

*Note: If vent pipe passes through any occupied areas above first floor, including storage spaces and closets, you must enclose pipe. You may frame and sheetrock enclosure with standard construction material. Make sure and meet the minimum allowable clearances to combustibles. Do not fill any required air spaces with insulation.*

## Vertical Termination Configurations

Figures 19 and 20, page 16, show the configurations for vertical termination.

If area above is an attic or insulated area, install firestop above framed hole.



If area above is a living space, install firestop below framed hole.

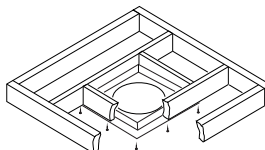


Figure 18 - Installing Firestop

# VENTING INSTALLATION

Continued

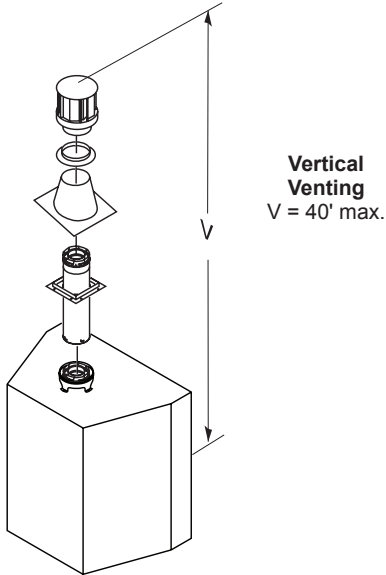


Figure 19 - Vertical Venting Configuration

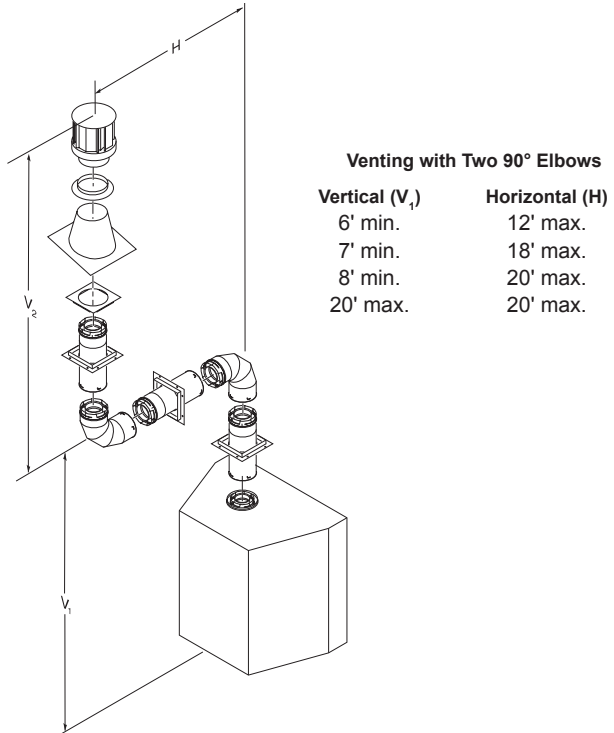


Figure 20 - Vertical Venting Configuration Using Two 90° Elbows

# VENTING INSTALLATION

*Continued*

## HIGH ALTITUDE INSTALLATION

Your FMI PRODUCTS, LLC direct vent fireplace has been tested and approved for elevations from 0-2000 feet.

Fireplaces for high altitude (-HA Models) are for installations above 4,000 feet only. These fireplaces are equipped with parts specific for higher altitudes.

When installing a non-high altitude fireplace at an elevation above 2000 feet, you may need to decrease the input rating by changing the existing burner orifice to a smaller size. Reduce input 4% for each 1000 feet above sea level. Check with your local gas company for proper orifice size identification.

When installing this fireplace at an elevation above 4500 feet, check with local authorities.

## PARTS LIST FOR VENTING KITS AND COMPONENTS

### FMI (5/8") Pipe & Vent Kits

<u>Number</u>	<u>Description</u>
P58-6	6" Section Double Wall Pipe, Galvanized
P58-12	12" Section Double Wall Pipe, Galvanized
P58-24	24" Section Double Wall Pipe, Galvanized
P58-36	36" Section Double Wall Pipe, Galvanized
P58-48	48" Section Double Wall Pipe, Galvanized
PA58-712	Adjustable 7"-12" Section Double Wall Pipe, Galvanized
E58-45	45° Elbow, Galvanized
E58-90	90° Elbow, Galvanized
HTS-58	Horizontal Square Termination, Galvanized
HHT-58	Horizontal High Wind Round Termination, Galvanized
VT-58	Vertical Round Termination, Galvanized
SC-58	Storm Collar, Galvanized
WF-58	Wall Firestop, Galvanized
RF-58-6	Roof Flashing - 0 to 6/12 Pitch, Galvanized
RF-58-12	Roof Flashing - 6/12 to 12/12 Pitch, Galvanized
VR-58	Vertical Restrictor, Galvanized
S-58	Vinyl Siding Standoff, Galvanized
WS-58	Wall Strap
CS-58	Cathedral Ceiling Support
FP-58	Firestop Plate
SF-58	Stucco Flashing - For use with HTS-58
RF-58	Flat Roof Flashing

# FIREPLACE INSTALLATION

## CHECK GAS TYPE

Use proper gas type for the fireplace unit you are installing. If you have conflicting gas types, do not install fireplace. See retailer where you purchased the fireplace for proper fireplace according to your gas type.

## INSTALLING GAS PIPING TO FIREPLACE LOCATION

**⚠ WARNING:** A qualified service person must connect fireplace to gas supply. Follow all local codes.

**⚠ CAUTION:** For propane/LP units, never connect fireplace directly to the propane/LP supply. This heater requires an external regulator (not supplied). Install the external regulator between the fireplace and propane/LP supply.

**⚠ WARNING:** For natural gas, never connect fireplace to private (non-utility) gas wells. This gas is commonly known as wellhead gas.

## Installation Items Needed

Before installing fireplace, make sure you have the items listed below.

- external regulator (supplied by installer)
- piping (check local codes)
- sealant (resistant to propane/LP gas)
- equipment shutoff valve \*
- test gauge connection \*
- sediment trap
- tee joint
- pipe wrench
- approved flexible gas line with gas connector (if allowed by local codes)

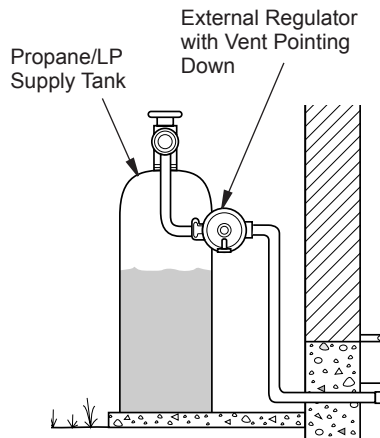
\* An equipment shutoff valve with 1/8" NPT tap is an acceptable alternative to test gauge connection. Purchase the equipment shutoff valve from your retailer.

For propane/LP connection only, the installer must supply an external regulator. The external regulator will reduce incoming gas pressure. You must reduce incoming gas pressure to between 11" and 14" of w.c. pressure. If you do not reduce incoming gas pressure, fireplace regulator damage could occur. Install external regulator with the vent pointing down as shown in Figure 21. Pointing the vent down protects it from freezing rain or sleet.

**⚠ CAUTION:** Use only new, black iron or steel pipe. Internally-tinned copper tubing may be used in certain areas. Check your local codes. Use pipe of 1/2" diameter or greater to allow proper gas volume to fireplace. If pipe is too small, undue loss of volume will occur.

Installation must include an equipment shutoff valve, union and plugged 1/8" NPT tap. Locate NPT tap within reach for test gauge hook up. NPT tap must be upstream from fireplace (see Figure 22, page 19).

**IMPORTANT:** Install main gas valve (equipment shutoff valve) in an accessible location. The main gas valve is for turning on or shutting off the gas to the appliance.



**Figure 21 - External Regulator with Vent Pointing Down (Propane/LP Only)**

# FIREPLACE INSTALLATION

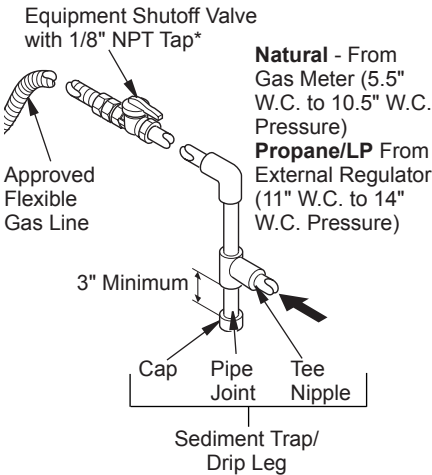
Continued

Check your building codes for any special requirements for locating equipment shutoff valve to fireplaces.

Apply pipe joint sealant lightly to male NPT threads. This will prevent excess sealant from going into pipe. Excess sealant in pipe could result in clogged fireplace valves.

**⚠ WARNING: Use pipe joint sealant that is resistant to liquid petroleum (LP) gas.**

We recommend that you install a sediment trap/drip leg in supply line as shown in Figure 22. Locate sediment trap/drip leg where it is within reach for cleaning. Install in piping system between fuel supply and fireplace. Locate sediment trap/drip leg where trapped matter is not likely to freeze. A sediment trap traps moisture and contaminants. This keeps them from going into fireplace gas controls. If sediment trap/drip leg is not installed or is installed wrong, fireplace may not run properly.



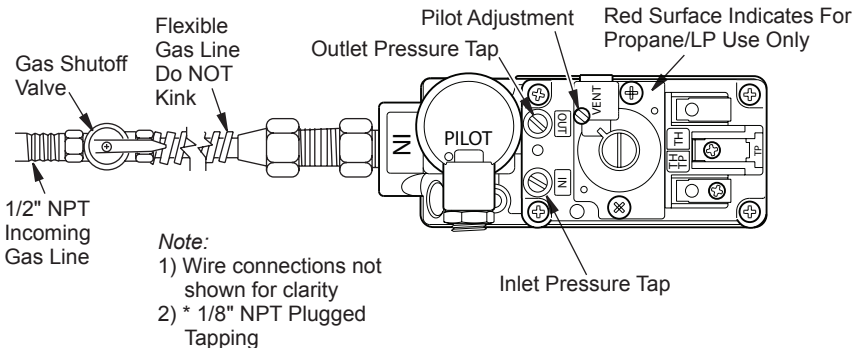
**Figure 22 - Gas Connection**

\* The equipment shutoff valve may be supplied with the appliance or you can purchase it from your retailer.

## CONNECTING FIREPLACE TO GAS SUPPLY

### Installation Items Needed

- 5/16" hex socket wrench or nut-driver
  - sealant (resistant to propane/LP gas, not provided)
1. Route flexible gas line (provided by installer) from equipment shutoff valve to fireplace. Route flexible gas supply line through one of the access holes on side of fireplace.
  2. Attach flexible gas line from gas supply to control valve (see Figure 23).
  3. Check all gas connections for leaks. See Checking Gas Connections, page 20.



**Figure 23 - Connecting Incoming Gas Line to Flex Gas Line**

# FIREPLACE INSTALLATION

Continued

## CHECKING GAS CONNECTIONS

**WARNING:** Test all gas piping and connections, internal and external to unit, for leaks after installing or servicing. Correct all leaks at once.

**WARNING:** Never use an open flame to check for a leak. Apply noncorrosive leak detection fluid to all joints. Bubbles forming show a leak. Correct all leaks at once.

## PRESSURE TESTING GAS SUPPLY PIPING SYSTEM

Test Pressures In Excess Of 1/2 PSIG (3.5 kPa)

1. Disconnect fireplace and its individual equipment shutoff valve from gas supply piping system. Pressures in excess of 1/2 psig (3.5 kPa) will damage fireplace gas regulator.
2. Cap off open end of gas pipe where equipment shutoff valve was connected.
3. Pressurize supply piping system by either opening propane/LP supply tank valve for propane/LP gas fireplace or opening main gas valve located on or near gas meter for natural gas fireplace or using compressed air.
4. Check all joints of gas supply piping system. Apply noncorrosive leak detection fluid to all joints. Bubbles forming show a leak. Correct all leaks at once.
5. Reconnect fireplace and equipment shutoff valve to gas supply. Check reconnected fittings for leaks.

Test Pressures Equal To or Less Than 1/2 PSIG (3.5 kPa)

1. Close equipment shutoff valve (see Figure 24).
2. Pressurize supply piping system by either opening propane/LP supply tank valve for propane/LP gas fireplace or opening main gas valve located on or near gas meter for natural gas fireplace or using compressed air.

3. Check all joints from propane/LP supply tank or gas meter to equipment shutoff valve (see Figure 25 or Figure 23). Apply noncorrosive leak detection fluid to all joints. Bubbles forming show a leak.
4. Correct all leaks at once.

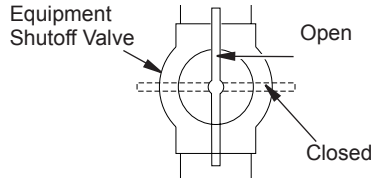


Figure 24 - Equipment Shutoff Valve

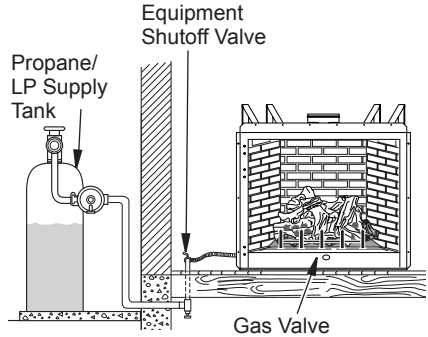


Figure 25 - Checking Gas Joints for Propane/LP Gas Fireplace

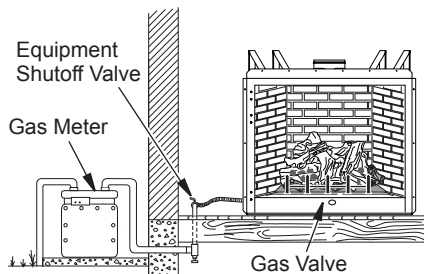


Figure 26 - Checking Gas Joints for Natural Gas Fireplace

## PRESSURE TESTING FIREPLACE GAS CONNECTIONS

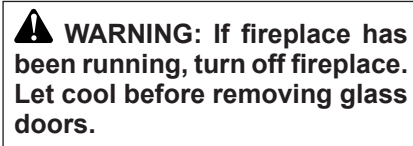
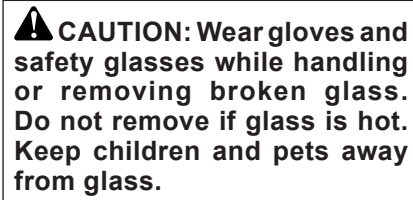
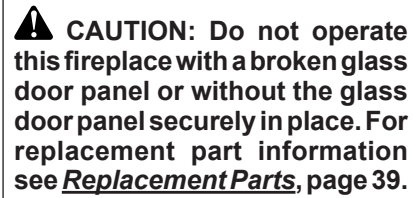
1. Open equipment shutoff valve (see Figure 24).
2. Open propane/LP supply tank valve for propane/LP fireplace or main gas valve located on or near gas meter for natural gas fireplace.

# FIREPLACE INSTALLATION

## Continued

3. Make sure control knob of fireplace is in the OFF position.
4. Check all joints from equipment shutoff valve to gas valve (see Figure 25 or Figure 26, page 20). Apply noncorrosive leak detection fluid to all joints. Bubbles forming show a leak. Correct all leaks at once.
5. Light fireplace (see *Operation*, page 25). Check all other internal joints for leaks.
6. Turn off fireplace (see *To Turn Off Gas to Appliance*, page 25).

## REMOVING/REPLACING GLASS DOOR



## Removing Glass Door

If replacement of glass is necessary, the entire frame assembly must be replaced. Gloves must be worn when removing/replacing glass door. If glass is broken tape remaining glass onto frame before removing.

1. Remove screens if installed.
2. Open bottom access panel.
3. Unlock 2 door latches on bottom of firebox.
4. Tilt open glass door 45° from the bottom of firebox and lift up to release door from firebox top retainer (see Figure 27).

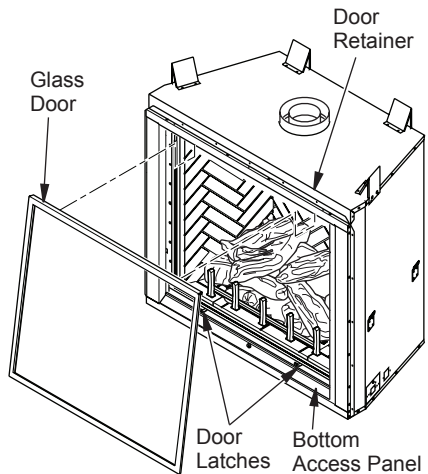


Figure 27 - Removing/Replacing Door

## Replacing Glass Door

1. Position door frame in front of firebox opening with bottom of door tilted away from firebox (see Figure 27).
2. Hook top flange of door frame over top of firebox frame.
3. Secure 2 bottom door latches.

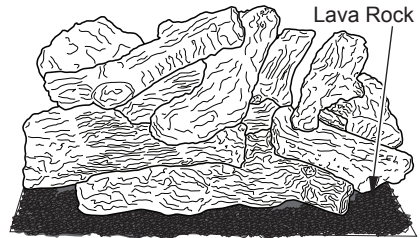
# FIREPLACE INSTALLATION

*Continued*

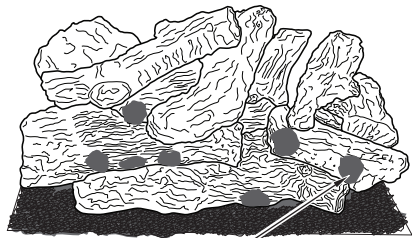
## LAVA ROCK, DECORATIVE GRATE, EMBER FLAKES AND SCRAP LOG INSTALLATION

Lava rock, ember flakes and scrap log pieces are included with your fireplace. Install these items while glass doors are open and/or removed.

1. Follow instructions from *Removing/Replacing Glass Door*, page 21, to move glass out of the way of this installation.
2. For 36" models only, install 3 loose logs by placing log #1, log #2 and log #3 onto one piece log as shown in Figure 28.
3. Place lava rock around base of burner. Make sure burner ports are not covered (see Figure 29).
4. Place ember flakes around front and sides of burner and on burner ports (see Figure 30). This will create the glowing ember appearance as the flame touches the ember flakes. Do not block burner ports or pilot ports by overlapping ember flakes in one area. It is not necessary to use all ember material provided.
5. Place scrap log pieces randomly behind grate as shown in Figure 31 on lava rock and around (but not on) burner ports.
6. Place grate in front of logs as shown in Figure 31. Be sure grate is balanced so it does not fall or lean onto logs. Grate does not attach to hearth assembly.



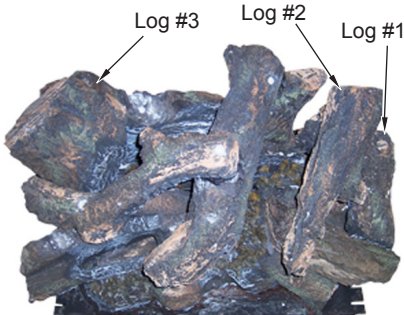
**Figure 29 - Installing Lava Rock**



**Figure 30 - Installing Ember Flakes**



**Figure 31 - Installing Scrap Log Pieces**



**Figure 28 - Installing Loose Logs**

## REMOVING LOG SET/BURNER MODULE

### Connecting and Disconnecting Gas Line

**⚠ WARNING: A qualified service person must connect and disconnect fireplace with gas supply. Follow all local codes.**

1. Using a 5/16" hex socket wrench or nut-driver, connect or disconnect flexible gas line and control valve (see Figure 32, page 23).
2. After connecting gas line to control valve, always test for leaks.

# FIREPLACE INSTALLATION

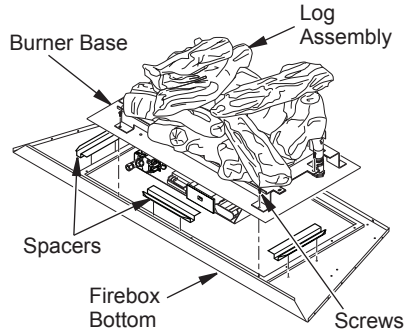
*Continued*

**⚠ WARNING:** Never use an open flame to check for a leak. Apply noncorrosive leak detection fluid to joints. Bubbles forming show a leak. Correct leaks at once.

**⚠ CAUTION:** The gas supply shall be shut off prior to disconnecting the electrical power, if any, before proceeding with this installation.

**⚠ CAUTION:** Use gloves when removing the log set/burner module from your firebox. Some metal edges may be sharp. Use caution with log sets as logs are fragile.

1. Remove glass door (see page 21).
2. Remove grate and all floor media (see page 22).
3. Carefully lift and remove 3 hearth refractories from fireplace.
4. Remove 3 spacers from firebox bottom (see Figure 33).
5. For 36" models only, remove 3 loose logs from log set (see Figure 28 page 22).
6. Remove 9 screws from front and sides of firebox burner base. Lift entire base from unit by pulling forward to disengage from rear flange and then lifting up (see Figure 33).
7. If needed, replace burner gasket before reinstalling log set/burner module (see replacement parts list on page 39.)

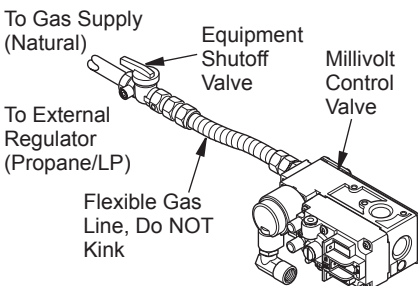


**Figure 33 - Removing/Installing Burner Base**

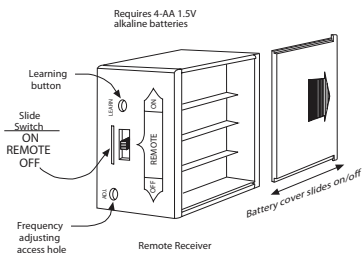
## INSTALLING BATTERIES IN WIRELESS HAND-HELD REMOTE CONTROL AND RECEIVER

### Installing Batteries in Remote Receiver

1. Open bottom access door.
2. Remove switch plate from receiver.
3. Gently pull receiver from mounting bracket. The receiver is still connected to the valve.
4. Remove battery housing cover on remote receiver to expose battery housing (see Figure 34).
5. Install 4 AA batteries into housing following positive and negative directions on battery housing cover removed in step 3 (see Figure 34).
6. Replace battery housing cover, place back into mounting bracket and cover with switch plate.
7. Install 2 D batteries into AC backup battery pack.
8. Close bottom access door.



**Figure 32 - Connecting/Disconnecting Gas Line to Millivolt Valve**



**Figure 34 - Installing Receiver Batteries (Included)**

# FIREPLACE INSTALLATION

*Continued*

## MATCHING SECURITY CODES

Each remote control can use one of 65,536 unique security codes. It may be necessary to program the remote receiver to "LEARN" the security code of the remote control upon initial use, if batteries are replaced or if a replacement remote control is purchased from your dealer. When matching security codes, be sure the slide button on the receiver is in the REMOTE position; the code will not "LEARN". If the slide switch is in the ON or OFF position. Program the remote receiver to "LEARN" a new security code by pushing the LEARN button on the top of the remote receiver and then pressing the MODE button on the remote control. A change in the beeping pattern, at the receiver, indicates the remote control's code has been programed into the receiver. When an existing receiver is matched to a new remote control, the new security code will override the old one.

The microprocessor that controls the security code matching procedure is controlled by a timing function. If you are unsuccessful in matching the security code on the first attempt, wait 1-2 minutes before trying again. This delay allows the microprocessor to reset its timer circuitry and try up to two or three more times.

## BATTERY LIFE

Life expectancy of the alkaline batteries in the remote control should be at least 12 months. Check and replace all batteries annually. When the remote control no longer operates the remote receiver from a distance it did previously or the remote receiver does not function at all, the batteries should be checked. It is important that the remote receiver batteries are fully charged and provide continuous output voltage of at least 5.3 Volts. The length of the wire, the more battery power is required to deliver signals between the remote receiver and the gas valve. Recommended length is no longer than 20 feet. The remote control should operate with as little as 9.0 Volts battery power.

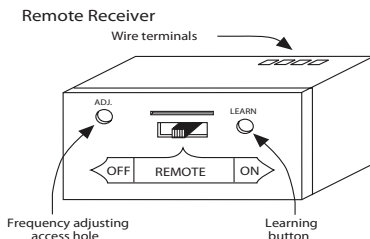
## TROUBLESHOOTING

If you encounter problems with your fireplace system, the problem may be with the fireplace itself or it could be with the remote control. Review the fireplace manufacturer's operation manual to make sure all connections are properly made. Then check the operation of the remote in the following manner:

- Make sure the batteries are correctly installed in the receiver. One reversed battery will keep the receiver from operating properly.
- Check batter in remote control to make sure contacts are touching (+) and (-) ends of battery. Bend metal contacts in for tighter fit.
- Be sure receiver and remote control are within 20 to 25 feet operating range.
- Keep receiver from temperatures exceeding 130°F. Battery life is shortened about this level.
- If receiver is installed in tightly enclosed metal surround, the operating distance will shorten.

## ADJUSTMENTS

- To adjust at the receiver, use a small slotted screwdriver. Turn the adjustment screw counter-clockwise about 5 degrees or a maximum of 1/8 turn. This should correct the distance problem.
- If the problem is not corrected, return adjustment screw to original position and then turn adjustment screw clockwise.
- This adjustment is like turning your radio dial. If you keep turning the adjustment screw, in either direction, you will go past the proper setting (tuning).



**Figure 35 - Adjusting the Receiver**

## OPERATION

### FOR YOUR SAFETY READ BEFORE LIGHTING

**⚠ WARNING:** If you do not follow these instructions exactly, a fire or explosion may result causing property damage, personal injury or loss of life.


- A. This appliance is equipped with an ignition device which automatically lights the pilot. Do not light pilot by hand.
- B. **BEFORE LIGHTING** smell all around the appliance area for gas. Be sure to smell next to the floor because some gas is heavier than air and will settle on the floor.


#### WHAT TO DO IF YOU SMELL GAS

- Do not try to light any appliance.
  - Do not touch any electric switch; do not use any phone in your building.
  - Immediately call your gas supplier from a neighbor's phone. Follow the gas supplier's instructions.
- C. Do not use this appliance if any part has been under water. Immediately call a qualified service technician to inspect the appliance and to replace any part of the control system and any gas control which has been under water.


### LIGHTING INSTRUCTIONS

**NOTICE:** During initial operation of new fireplace, burning logs will give off a paper-burning smell. Orange flame will also be present. Open damper or window to vent smell. This will only last a few hours.

1. STOP! Read the safety information in column 1.
2. Turn off all electric power to fireplace.
3. Turn safety shutoff switch to the OFF position.
4. Remove center brick/control cover.
5. Turn equipment shutoff valve clockwise  to the OFF position (see Figure 36). Do not force.

6. Wait five (5) minutes to clear out any gas. Then smell for gas, including near the floor. If you smell gas, STOP! Follow "B" in the safety information page 22. If you don't smell gas, go to the next step.
7. Turn equipment shutoff valve counter-clockwise  to the ON position. Do not force.
8. Replace center brick/control cover.
9. Turn on all electric power to appliance.
10. Turn safety shutoff switch to the ON position.
11. Visually locate pilot. Ignitor should begin to spark and main burner should ignite once flame appears at pilot.
  - If lighting appliance for the first time each season, it may take several attempts before supply gas can reach pilot and main burners.
  - If appliance will not stay lit after several attempts, follow instructions under To Turn Off Gas To Appliance and call your service technician or gas supplier.

### TO TURN OFF GAS TO APPLIANCE

1. Turn off safety shutoff switch.
2. Turn off all electric power to appliance if service is to be performed.
3. Remove center brick/control cover.
4. Turn equipment shutoff valve clockwise  to OFF. Do not force.
5. Replace center brick/control cover.

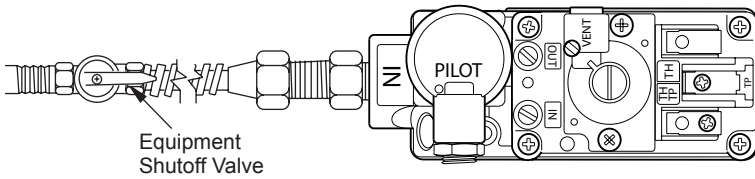
### REMOTE OPERATION

1. Turn equipment shutoff valve to ON position. You can now turn the burner on and off with hand-held remote control unit.

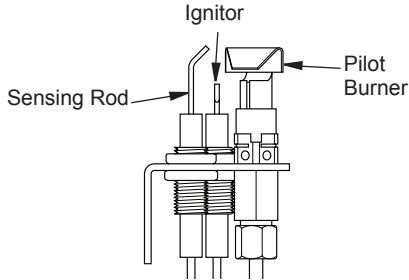
**IMPORTANT:** Be sure to press ON/OFF buttons on hand-held remote control unit for up to 3 seconds to assure proper operation.
2. Press ON/OFF button to turn burner on and off.

## OPERATION

*Continued*



**Figure 36 - Turning Equipment Shutoff Valve to the OFF Position**



**Figure 37 - Pilot**

## INSPECTING BURNERS

Check pilot flame pattern and burner flame patterns often.

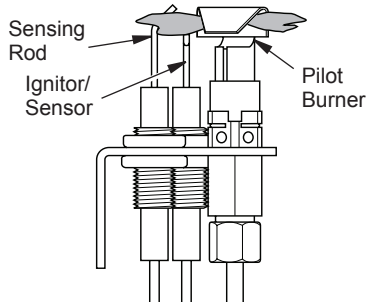
### PILOT ASSEMBLY

The pilot assembly is factory preset for the proper flame. Alterations may have occurred during shipping and handling. The pilot is located on right hand side of burner.

The flame must envelope 1/4" of top of the ignitor/sensor and grounding stem.

If your pilot assembly does not meet these requirements:

- Turn the adjustment screw marked PILOT clockwise to decrease or counterclockwise to increase the flame to proper size (see Figure 36). Do not remove the adjustment screw.
- see [Troubleshooting](#), page 29



**Figure 38 - Correct Pilot Flame Pattern**

# INSPECTING BURNERS

*Continued*

## BURNER FLAME PATTERN

Burner flames will be steady, not lifting or floating. Flame patterns will be different from unit to unit and will vary depending on installation type and weather conditions.

If the vent configuration is installed incorrectly, flames will lift or "ghost". This can be dangerous. Inspect flames after installation to ensure proper installation and performance.

Figure 39 shows a typical flame pattern.

If burner flame pattern differs from that described:

- turn fireplace off (see *To Turn Off Gas to Appliance*, page 25)
- see *Troubleshooting*, page 29



**Figure 39 - Typical Flame Pattern**

## CLEANING AND MAINTENANCE

**⚠ WARNING:** Turn off fireplace and let cool before cleaning.

**⚠ CAUTION:** You must keep control areas, burners and circulating air passageways of fireplace clean. Inspect these areas of fireplace before each use. Have fireplace inspected yearly by a qualified service person. Fireplace may need more frequent cleaning due to excessive lint from carpeting, bedding material, pet hair, etc.

**⚠ WARNING:** Do not use abrasive cleaners as this may damage glass. Use a nonabrasive household glass cleaner to clean glass. Do not clean glass when hot.

Glass must be cleaned periodically. During start-up it is normal for condensation to form on the inside of the glass causing lint, dust and other airborne particles to cling to the glass surface. During initial start-up a slight film may form on the glass due to paint curing. The glass should be cleaned several times with a non-ammonia, nonabrasive household cleaner and warm water after the first two weeks of operation. Thereafter, clean the glass two or three times during each heating season, depending on the usage and circumstances present. Refer to *Removing/Replacing Glass Door*, page 21 of this manual when removing glass door for cleaning.

## GLASS DOORS

**⚠ WARNING:** Handle glass door panels with care. Do not strike, slam or otherwise abuse glass. Do not operate fireplace with the glass door unlatched, removed, cracked or broken.

## CLEANING AND MAINTENANCE

*Continued*

**⚠ WARNING:** Only parts supplied by the manufacturer should be used when replacing broken or damaged glass door panels (see [Replacement Parts](#), page 39). Glass door panel are complete units. No substitute materials may be used.

**⚠ CAUTION:** Wear gloves and safety glasses while handling or removing broken glass. Do not remove if glass is hot. Keep children and pets away from glass.

If glass has been broken, carefully remove glass door (see [Removing/Replacing Glass Door](#), page 21). Vacuum all glass pieces with a shop vac.

**⚠ CAUTION:** Do not vacuum if pieces are hot.

Use only glass door replacement intended for this fireplace (see [Replacement Parts](#), page 39 for detail on ordering). No substitutions may be made. See [Removing/Replacing Glass Door](#), page 21 for instructions for replacing glass doors.

**⚠ WARNING:** Do not operate fireplace with glass door unlatched, removed, cracked or broken.

### PILOT AND BURNERS

- Remove material before cleaning burners and replace when cleaning is complete.
- Burner and controls should be cleaned with compressed air to remove dust, dirt or lint.
- Use a vacuum cleaner or small, soft bristled brush to remove excess dust, dirt or lint.

### LOGS

- Use a vacuum cleaner to remove any carbon buildup on logs.
- Replace material periodically as needed. See [Replacement Parts](#), page 39.


### VENTING SYSTEM

Conduct annual inspection of the venting system following these guidelines:

1. Check areas of venting system that are exposed to the weather for corrosion (rust spots or streaks and, in extreme cases, holes). Have these items replaced immediately by a qualified service person.
2. Remove the vent cap and shine a flashlight into the vent. Remove any foreign material.
3. Check for evidence of excessive condensation. Continuous condensation can cause corrosion of caps, pipes and fittings and can be caused by having excessive lateral runs, too many elbows or exterior portions of the system being exposed to cold weather.
4. Inspect joints to verify that no pipe section or fitting has been disturbed and loosened. Check mechanical supports such as wall straps for rigidity.

## TROUBLESHOOTING

 **WARNING:** Turn off fireplace and let cool before servicing. Only a qualified service person should service and repair fireplace.

 **CAUTION:** Never use a wire, needle or similar object to clean pilot. This can damage pilot unit.

*Note: All troubleshooting items are listed in order of operation.*

OBSERVED PROBLEM	POSSIBLE CAUSE	REMEDY
Ignitor will not spark or pilot will not light	1. No gas supply or shutoff valve is OFF	1. Check to see if you have gas supply and that equipment shutoff valve is opened
	2. Air in gas line	2. Repeat lighting procedure several times to purge all air out of lines. If after repeated attempts appliance does not light, call for qualified service and repair
	3. Construction debris clogging pilot orifice	3. Remove debris and dirt, inspect and clean any other possible obstructions
	4. Low gas pressure	4. Contact your gas supplier to check pressure
	5. Kinked pilot line	5. Have a qualified technician replace pilot line
	6. Control valve is not opening	6. Replace control valve (Refer to <u>Replacement Parts</u> , page 39)
	7. No power to unit or ignition module or power transformer is bad	7. Check that main power is on and that all wire connections are made correctly to ignition model (see <u>Wiring Diagram</u> , page 38). Check for 24 VAC at the secondary side of transformer. If 24 VAC is present and module does not operate, have module replaced. Otherwise have transformer replaced

## TROUBLESHOOTING

*Continued*

OBSERVED PROBLEM	POSSIBLE CAUSE	REMEDY
Pilot will not stay lit	<ol style="list-style-type: none"><li>1. Loose wiring on ignitor wire to ignition module and/or poor ground to ignition module</li><li>2. Pilot flame too low to sense</li></ol>	<ol style="list-style-type: none"><li>1. Check wiring connection. Refer to wiring diagram (see <i>Wiring Diagram</i>, page 38) and/or check ground wire to ignition module</li><li>2. Clean and adjust pilot burner and check gas supply and inlet pressure to unit <i>Note: Have a qualified technician replace pilot assembly if broken or corroded</i></li></ol>
No gas to burner, although safety shutoff switch and valve are set to the ON position	<ol style="list-style-type: none"><li>1. Safety shutoff switch wires defective or too long</li></ol>	<ol style="list-style-type: none"><li>1. Check electrical connections</li></ol>
Frequent pilot outage	<ol style="list-style-type: none"><li>1. Pilot flame may be too low, causing safety pilot to “drop out”</li><li>2. Improper venting or excessive blockage</li></ol>	<ol style="list-style-type: none"><li>1. Clean and adjust pilot flame for maximum flame impingement on thermopile</li><li>2. Have vent system inspected, including termination cap. Remove any restriction or obstruction</li></ol>
Fireplace produces a clicking/ticking noise just after burner is lit or shut off	<ol style="list-style-type: none"><li>1. Metal expanding while heating or contracting while cooling</li></ol>	<ol style="list-style-type: none"><li>1. This is normal with most fireplaces. If noise is excessive, contact qualified service person</li></ol>
Slight smoke or odor during initial operation	<ol style="list-style-type: none"><li>1. Residues from manufacturing processes and logs curing</li></ol>	<ol style="list-style-type: none"><li>1. Problem will stop after a few hours of operation</li></ol>

# TROUBLESHOOTING

*Continued*



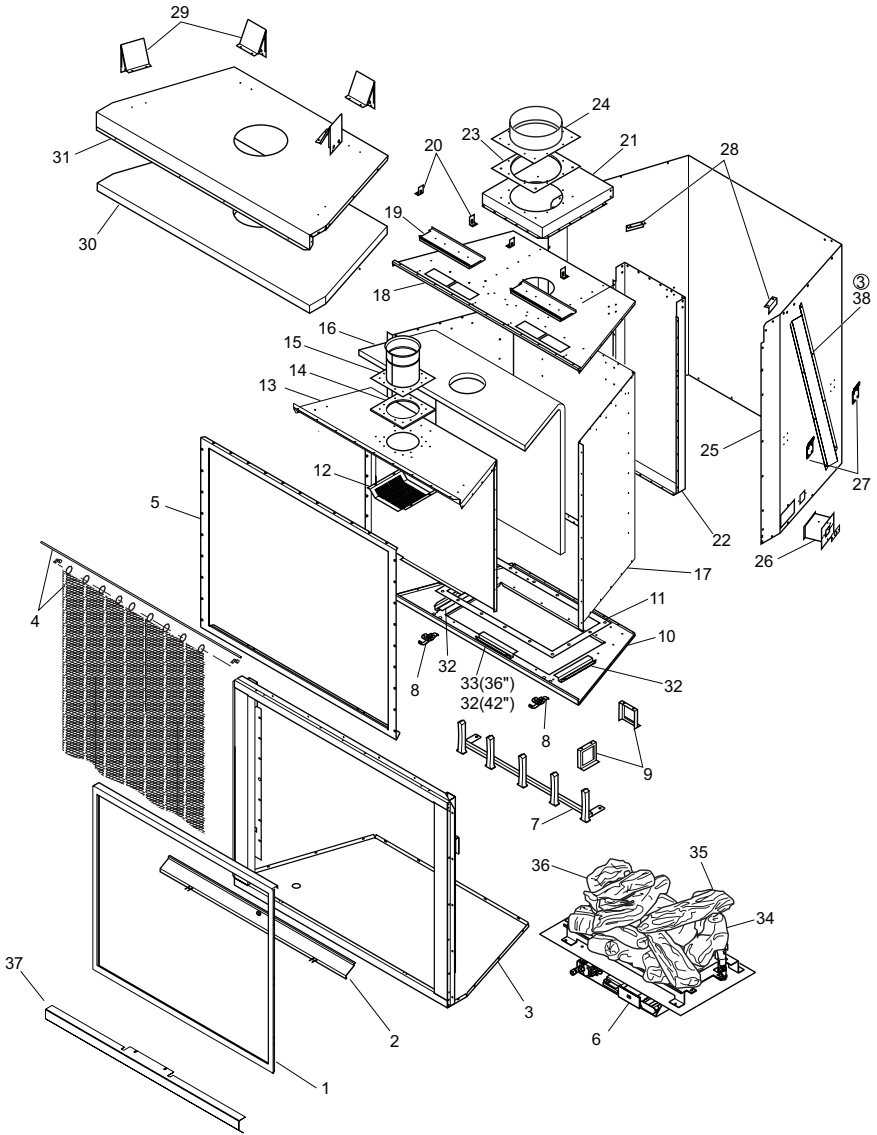
**WARNING: If you smell gas**

- Shut off gas supply.
- Do not try to light any appliance.
- Do not touch any electrical switch; do not use any phone in your building.
- Immediately call your gas supplier from a neighbor's phone. Follow the gas supplier's instructions.
- If you cannot reach your gas supplier, call the fire department.

OBSERVED PROBLEM	POSSIBLE CAUSE	REMEDY
Gas odor even when gas control valve is off	<ol style="list-style-type: none"> <li>1. Gas leak. <b>See Warning statement at top of page</b></li> <li>2. Control valve defective</li> </ol>	<ol style="list-style-type: none"> <li>1. Locate and correct all leaks (see <u>Checking Gas Connections</u>, page 20)</li> <li>2. Replace control valve</li> </ol>
Gas odor during combustion	<ol style="list-style-type: none"> <li>1. Foreign matter between control valve and burner</li> <li>2. Gas leak. <b>See Warning statement at top of page</b></li> </ol>	<ol style="list-style-type: none"> <li>1. Take apart gas tubing and remove foreign matter</li> <li>2. Locate and correct all leaks (see <u>Checking Gas Connections</u>, page 20)</li> </ol>
Glass soots	<ol style="list-style-type: none"> <li>1. Debris around burner air mixer</li> <li>2. Improper vent configuration</li> </ol>	<ol style="list-style-type: none"> <li>1. Inspect opening at base of burner to see that it is NOT packed with any type of material</li> <li>2. Check vent configuration specification (see <u>Venting Installation</u>, page 10)</li> </ol>
Dark residue on logs or inside of fireplace	<ol style="list-style-type: none"> <li>1. Air holes at burner inlet blocked</li> <li>2. Burner flame holes blocked</li> <li>3. Improper venting or excessive blockage</li> <li>4. Excessive amounts of embers and pan material</li> </ol>	<ol style="list-style-type: none"> <li>1. Clean out air holes at burner inlets. Periodically repeat as needed</li> <li>2. Remove blockage</li> <li>3. Have vent system inspected, including termination cap. Remove any restrictions or obstruction</li> <li>4. Clear excess embers until a minimum gap of 1/2" remains under grate</li> </ol>

# PARTS

MODELS (V)DVF36NS, (V)DVF36PS, (V)DVF36NH, (V)DVF36PH, DVF-36NS-HA, DVF36NH-HA, (V)DVF42NS, (V)DVF42PS, (V)DVF42NH, (V)DVF42PH, DVF-42NS-HA, AND DVF42NH-HA



## PARTS

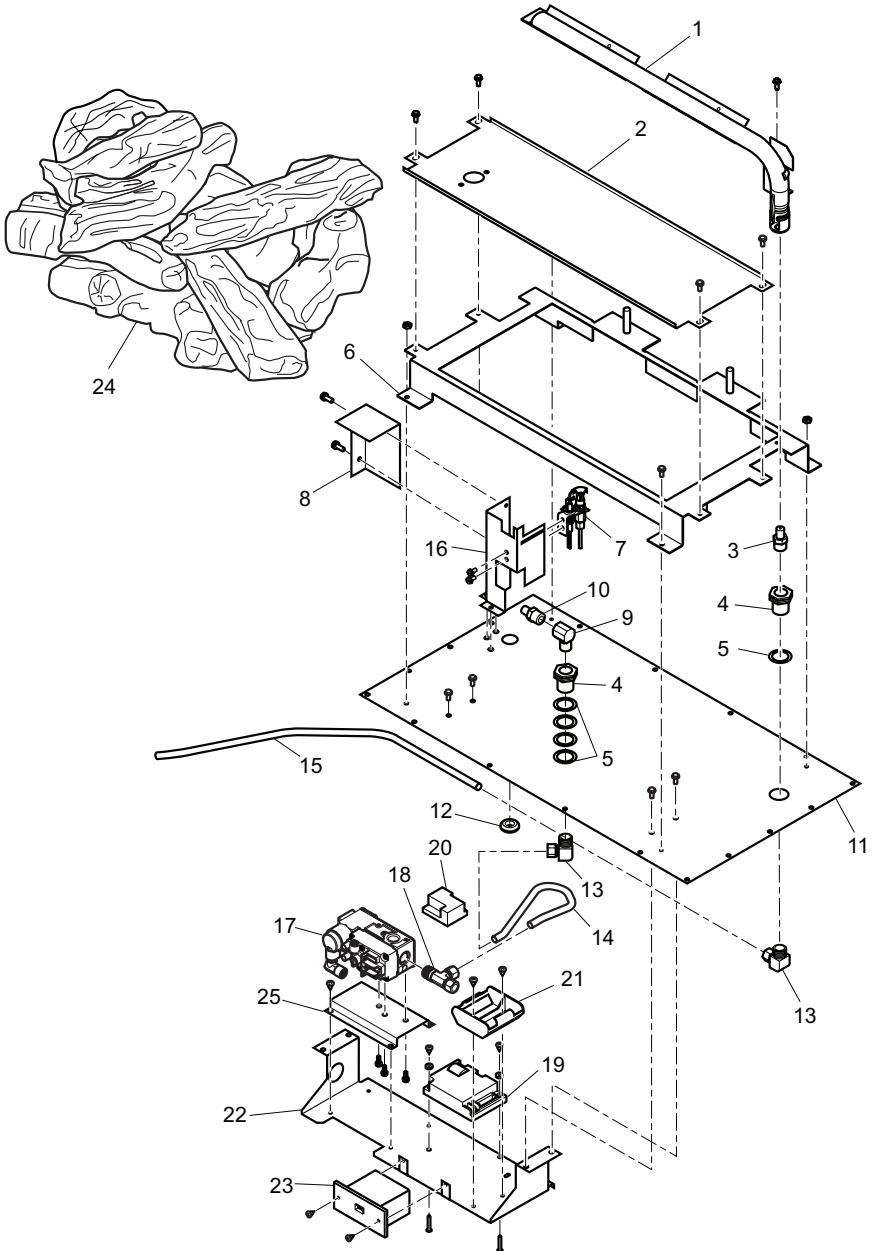
This list contains replaceable parts used in your fireplace. When ordering parts, follow the instructions listed under Replacement Parts on page 39 of this manual.

KEY NO.	PART NO.	DESCRIPTION							QTY.
			(V)DVF36N(H,S)	(V)DVF36P(H,S)	(V)DVF42N(H,S)	(V)DVF42P(H,S)	DVF36N(H,S)-HA	DVF42N(H,S)-HA	
1	122653-01	Door Assembly, 36"	•	•					1
	122653-02	Door Assembly, 42"			•	•	•	•	1
2	122950-02	Bottom Door Assembly, 36"	•	•			•	•	1
	122950-01	Bottom Door Assembly, 42"			•	•	•	•	1
3	121301-01	Face Assembly, 36"	•	•			•	•	1
	121301-02	Face Assembly, 42"			•	•	•	•	1
4	122952-02	Screen Door Kit, 36"	•	•			•	•	1
	122952-01	Screen Door Kit, 42"			•	•	•	•	1
5	**	Firebox Face	•	•	•	•	•	•	1
6	122842-03	Hearth Assembly, 36" NG	•						1
	122842-04	Hearth Assembly, 36" Propane/LP		•					1
	122842-01	Hearth Assembly, 42" NG			•				1
	122842-02	Hearth Assembly, 42" Propane/LP				•			1
	123781-01	Hearth Assembly, 36" NG, High Altitude					•		1
	123781-02	Hearth Assembly, 42" NG, High Altitude						•	1
7	123210-01	Grate, 36"	•	•			•	•	1
	123210-02	Grate, 42"			•	•	•	•	1
8	122652-01	Door Latch	•	•	•	•	•	•	2
9	**	Firebox Leg	•	•	•	•	•	•	4
10	**	Firebox Bottom	•	•	•	•	•	•	1
11	121431-01	Gasket, 36"	•	•			•	•	1
	111913-02	Gasket, 42"			•	•	•	•	1
12	122919-01	Draft Diverter	•	•	•	•	•	•	1
13	**	Air Exchange	•	•	•	•	•	•	1
14	**	5" Gasket	•	•	•	•	•	•	1
15	**	5" Inner Connector	•	•	•	•	•	•	1
16	**	A/E Insulation	•	•	•	•	•	•	1
17	**	Firebox Surround	•	•	•	•	•	•	1
18	**	Firebox Top	•	•	•	•	•	•	1
19	**	Relief Assembly	•	•	•	•	•	•	2
20	**	Relief Bracket	•	•	•	•	•	•	4
21	**	Top Plenum			•	•	•	•	1
22	**	Rear Plenum			•	•	•	•	1
23	**	5" Gasket	•	•	•	•	•	•	1
24	**	Connector, 8" x 3.25"	•	•	•	•	•	•	1
25	121295-01	36" Fireplace Surround	•	•			•	•	1
	121302-01	42" Fireplace Surround			•	•	•	•	1
26	110037-01	Electrical Duct Assembly	•	•	•	•	•	•	1
27	117891-01	Fireplace Handle	•	•	•	•	•	•	4
28	120520-01	Refractory Retainer	•	•	•	•	•	•	3
29	20280	Top Spacer	•	•	•	•	•	•	4
30	**	Top Insulation	•	•	•	•	•	•	1
31	**	Fireplace Top	•	•	•	•	•	•	1
32	**	Hearth Side Spacer	•	•	•	•	•	•	2,3
33	**	Hearth Front Spacer	•	•			•	•	1
34	123182-01	Log #1	•	•	•	•	•	•	1
35	123181-01	Log #2			•	•	•	•	1
36	123211-01	Log #3			•	•	•	•	1
37	125104-01	Draft Shield 36"	•	•			•	•	1
	125104-02	Draft Shield 42"			•	•	•	•	1
38	109720-03	Spacer Clearance	•	•	•	•	•	•	3

\*\*Not a field replaceable part.

## PARTS

BURNER ASSEMBLY MODELS (V)DVF36NS, (V)DVF36PS, (V)DVF36NH, (V)DVF36PH, DVF-36NS-HA, DVF36NH-HA, (V)DVF42NS, (V)DVF42PS, (V)DVF42NH, (V)DVF42PH, DVF-42NS-HA, AND DVF42NH-HA



## PARTS

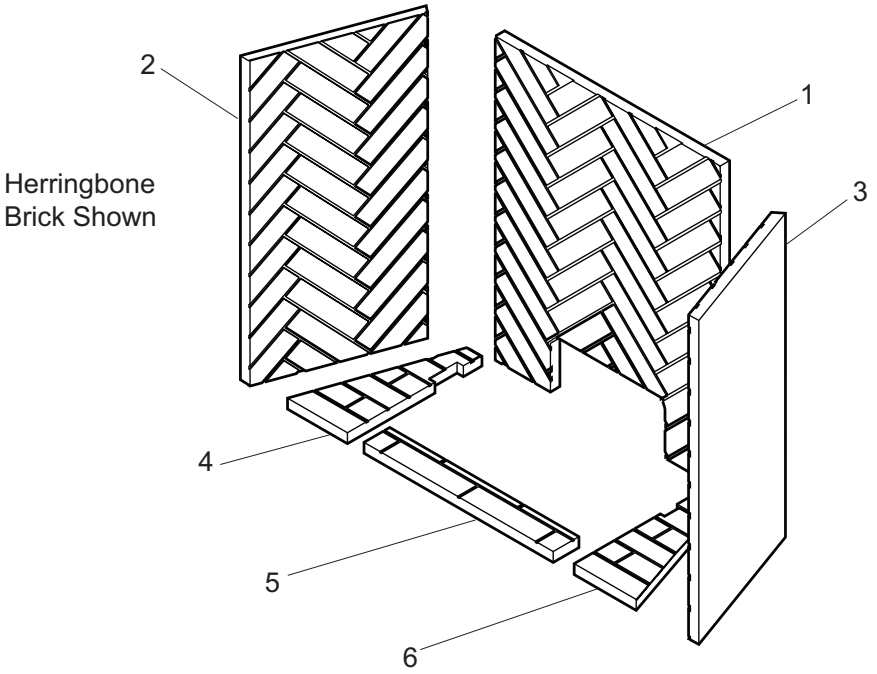
### BURNER ASSEMBLY

This list contains replaceable parts used in your fireplace. When ordering parts, follow the instructions listed under Replacement Parts on page 39 of this manual.

KEY NO.	PART NO.	DESCRIPTION	(V)DV F36N(H,S)	(V) DV F36P(H,S)	(V)DV F42N(H,S)	(V)DV F42P(H,S)	DV F36N(H,S)-HA	DV F42N(H,S)-HA	QTY.
1	122839-02	Burner Tube, 36"	•	•					1
	122839-01	Burner Tube, 42"			•	•			1
2	**	Front Burner Assembly	•	•	•	•	•	•	1
3	112371-15	Rear Orifice, #47 NG	•				•		1
	23100	Rear Orifice, #56 Propane/LP		•					1
	23101	Rear Orifice, #44 NG			•		•		1
	23567	Rear Orifice, #55 Propane/LP				•			1
4	11214	Bulkhead Fitting	•	•	•	•	•	•	2
5	116573-01	Washer, Flt 7/8"x1 1/4" OD	•	•	•	•	•	•	5
6	**	Log/Burner Base	•	•	•	•	•	•	1
7	122122-01	Pilot, NG	•	•					1
	122122-02	Pilot, Propane/LP		•	•				1
	123783-01	Pilot, NG High Altitude					•	•	1
8	**	Pilot Shield	•	•	•	•	•	•	1
9	14296	Elbow, Street 3/8"	•	•	•	•	•	•	1
10	112371-15	Front Orifice, #47 NG	•				•		1
	23100	Front Orifice, #56 Propane/LP		•					1
	24771	Front Orifice, #42 NG			•		•		1
	23100	Front Orifice, #56 Propane/LP				•			1
11	**	Base	•	•	•	•	•	•	1
12	114027-01	Grommet SC 1/2" ID 1 1/16" OD	•	•	•	•	•	•	1
13	14399	90° Elbow, Brass 3/8" Tube x 3/8" NPT	•	•	•	•	•	•	2
14	111817-06	Flextube Dormont, 3/8" Dia. x 11"	•	•	•	•	•	•	1
15	111817-09	Flextube Dormont, 3/8" Dia. x 24"	•	•	•	•	•	•	1
16	**	Pilot Bracket	•	•	•	•	•	•	1
17	122116-01	Dexen Valve, NG	•	•					1
	122117-01	Dexen Valve, LP		•	•				1
	123782-01	Dexen Valve, NG High Altitude 3.8"					•	•	1
18	112823-01	Brass T-Fitting 3/8"	•	•	•	•	•	•	1
19	122118-01	Control Module	•	•	•	•	•	•	1
20	122119-01	Battery Relay	•	•	•	•	•	•	1
21	122121-01	Battery Pack	•	•	•	•	•	•	1
22	122860-01	Valve Bracket	•	•	•	•	•	•	1
23	125243-01	Remote Control Kit	•	•	•	•	•	•	1
24	**	Log Assembly, 36"	•	•			•		1
	**	Log Assembly, 42"			•	•	•	•	1
25	123560-01	Base Valve	•	•	•	•	•	•	1
<b>PARTS AVAILABLE NOT SHOWN</b>									
	122120-01	Wire Harness Relay	•	•	•	•	•	•	1
	122123-01	AC Adapter 3V	•	•	•	•	•	•	1
	112799-01	Ember Flakes Kit	•	•	•	•	•	•	1
	26839	Rockwool	•	•	•	•	•	•	1
	GA6060	Lave Rock Kit	•	•	•	•	•	•	1
	VTA-LS5-2	Log Scrap Kit	•	•	•	•	•	•	1
	14253	30" Flex Line	•	•	•	•	•	•	1

# PARTS

## REFRACTORY PARTS



# PARTS

## REFRACTORY PARTS

KEY NO.	PART NO.	DESCRIPTION	DVF42(N,PI/H(-HA)	DVF36(N,PI/H(-HA)	DVF42(N,PI/S(-HA)	DVF36(N,PI/S(-HA)	VDVF42(N,PI/H	VDVF36(N,PI/H	VDVF42(N,PI/S	VDVF36(N,PI/S	QTY.
1	125124-01	Rear Refractory, Herringbone 42" White					•				1
	125124-02	Rear Refractory, Herringbone 42" Red	•								1
	125088-01	Rear Refractory, Herringbone 36" White						•			1
	125088-02	Rear Refractory, Herringbone 36" Red	•								1
	125123-01	Rear Refractory, Stacked 42" White							•		1
	125123-02	Rear Refractory, Stacked 42" Red			•						1
	125087-01	Rear Refractory, Stacked 36" White								•	1
	125087-02	Rear Refractory, Stacked 36" Red				•					1
2	125126-01	Left Refractory, Herringbone 42" White							•		1
	125126-02	Left Refractory, Herringbone 42" Red	•								1
	125090-01	Left Refractory, Herringbone 36" White						•			1
	125090-02	Left Refractory, Herringbone 36" Red		•							1
	125123-01	Left Refractory, Stacked 42" White							•		1
	125123-02	Left Refractory, Stacked 42" Red			•						1
	125089-01	Left Refractory, Stacked 36" White								•	1
	125089-02	Left Refractory, Stacked 36" Red				•					1
3	125128-01	Right Refractory, Herringbone 42" White							•		1
	125128-02	Right Refractory, Herringbone 42" Red	•								1
	125092-01	Right Refractory, Herringbone 36" White						•			1
	125092-02	Right Refractory, Herringbone 36" Red		•							1
	125127-01	Right Refractory, Stacked 42" White							•		1
	125127-02	Right Refractory, Stacked 42" Red			•						1
	125091-01	Right Refractory, Stacked 36" White								•	1
	125091-02	Right Refractory, Stacked 36" Red				•					1
4	125129-01	Left Front Refractory 42" White						•		•	1
	125129-02	Left Front Refractory 42" Red	•		•						1
	125093-01	Left Front Refractory 36" White						•		•	1
	125093-02	Left Front Refractory 36" Red		•		•					1
5	125131-01	Center Front Refractory 42" White						•		•	1
	125131-02	Center Front Refractory 42" Red	•		•						1
	125095-01	Center Front Refractory 36" White						•		•	1
	125095-02	Center Front Refractory 36" Red		•		•					1
6	125130-01	Right Front Refractory 42" White						•		•	1
	125130-02	Right Front Refractory 42" Red	•		•						1
	125094-01	Right Front Refractory 36" White						•		•	1
	125094-02	Right Front Refractory 36" Red		•		•					1

## SPECIFICATIONS

### (V)DVF36NS, (V)DVF36NH

- Rating: 33,500 Btu/hr
- Gas Type: Natural Gas Only
- Ignition: Electronic
- Manifold Pressure: 3.5" w.c.
- Minimum Inlet Supply Pressure: 5" w.c.
- Maximum Inlet Supply Pressure: 10.5" w.c.
- Front Orifice: #47
- Rear Orifice: #47

### (V)DVF42NS, (V)DVF42NH

- Rating: 41,000 Btu/hr
- Gas Type: Natural Gas Only
- Ignition: Electronic
- Manifold Pressure: 3.5" w.c.
- Minimum Inlet Supply Pressure: 5" w.c.
- Maximum Inlet Supply Pressure: 10.5" w.c.
- Front Orifice: #42
- Rear Orifice: #44

### (V)DVF36PS, (V)DVF36PH

- Rating: 31,000 Btu/hr
- Gas Type: Propane/LP Gas Only
- Ignition: Electronic
- Manifold Pressure: 10" w.c.
- Minimum Inlet Supply Pressure: 11" w.c.
- Maximum Inlet Supply Pressure: 13" w.c.
- Front Orifice: #56
- Rear Orifice: #56

### (V)DVF42PS, (V)DVF42PH

- Rating: 37,000 Btu/hr
- Gas Type: Propane/LP Gas Only
- Ignition: Electronic
- Manifold Pressure: 10.0" w.c.
- Minimum Inlet Supply Pressure: 11" w.c.
- Maximum Inlet Supply Pressure: 13" w.c.
- Front Orifice: #56
- Rear Orifice: #55

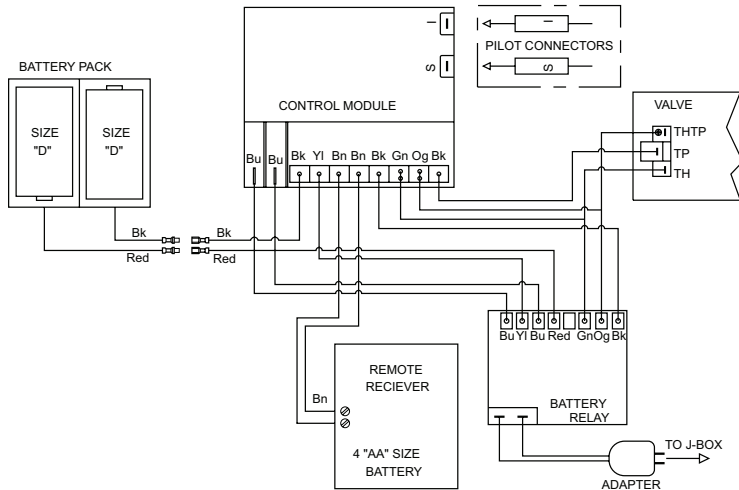
### DVF36NS-HA, DVF36NH-HA

- Rating: 33,500 Btu/hr
- Gas Type: Natural Gas Only
- Ignition: Electronic
- Manifold Pressure: 3.8" w.c.
- Minimum Inlet Supply Pressure: 5" w.c.
- Maximum Inlet Supply Pressure: 10.5" w.c.
- Front Orifice: #47
- Rear Orifice: #47

### DVF42NS-HA, DVF42NH-HA

- Rating: 41,000 Btu/hr
- Gas Type: Natural Gas Only
- Ignition: Electronic
- Manifold Pressure: 3.8" w.c.
- Minimum Inlet Supply Pressure: 5" w.c.
- Maximum Inlet Supply Pressure: 10.5" w.c.
- Front Orifice: #42
- Rear Orifice: #44

## WIRING DIAGRAM



## REPLACEMENT PARTS

*Note: Use only original replacement parts. This will protect your warranty coverage for parts replaced under warranty.*

Contact authorized dealers of this product. If they can't supply original replacement part(s), call FMI PRODUCTS, LLC at 1-866-328-4537.

When calling, have ready:

- your name
- your address
- model and serial numbers of your heater
- how heater was malfunctioning
- purchase date

Usually, we will ask you to return the part to the factory.

## TECHNICAL SERVICE

You may have further questions about installation, operation, or troubleshooting. If so, contact FMI PRODUCTS, LLC at 1-866-328-4537. When calling please have your model and serial numbers of your heater ready.

You can also visit our web site at [www.fmiproducts.com](http://www.fmiproducts.com).

## SERVICE HINTS

### When Gas Pressure Is Too Low

- pilot will not stay lit
- burners will have delayed ignition
- fireplace will not produce specified heat
- propane/LP gas supply might be low (propane/LP units only)

You may feel your gas pressure is too low. If so, contact your local gas supplier.

## ACCESSORIES

Purchase these accessories from your local dealer. If they can not supply these accessories call FMI PRODUCTS, LLC at 1-866-328-4537 for information. You can also write to the address listed on the back page of this manual.

### Brick Perimeter Trim Kit

PBS36 - Red

VPBS36 - Ivory

PBS42 - Red

VPBS42 - Ivory

Magnetic attachment, Matching refractory brick facing surround kit.

### Propane/Natural Gas Conversion Kit

IMPORTANT: NOT to be used for High Altitude (-HA) Models

PCD-36S - Propane/LP Gas Conversion Kit

NCD-36S - Natural Gas Conversion Kit

PCD-42S - Propane/LP Gas Conversion Kit

NCD-42S - Natural Gas Conversion Kit

# WARRANTY

## KEEP THIS WARRANTY

Model (located on product or identification tag) \_\_\_\_\_

Serial No. (located on product or identification tag) \_\_\_\_\_

Date Purchased \_\_\_\_\_

Keep receipt for warranty verification.

## FMI PRODUCTS, LLC LIMITED WARRANTIES

### New Products

**Standard Warranty:** FMI PRODUCTS, LLC warrants this new product and any parts thereof to be free from defects in material and workmanship for a period of four (4) years from the date of first purchase from an authorized dealer provided the product has been installed, maintained and operated in accordance with FMI PRODUCTS, LLC's warnings and instructions.

For products purchased for commercial, industrial or rental usage, this warranty is limited to 90 days from the date of first purchase.

### Factory Reconditioned Products

**Limited Warranty:** FMI PRODUCTS, LLC warrants factory reconditioned products and any parts thereof to be free from defects in material and workmanship for 30 days from the date of first purchase from an authorized dealer provided the product has been installed, maintained and operated in accordance with FMI PRODUCTS, LLC's warnings and instructions.

### Terms Common to All Warranties

The following terms apply to all of the above warranties:

Always specify model number and serial number when contacting the manufacturer. To make a claim under this warranty the bill of sale or other proof of purchase must be presented.

This warranty is extended only to the original retail purchaser when purchased from an authorized dealer, and only when installed by a qualified installer in accordance with all local codes and instructions furnished with this product.

This warranty covers the cost of part(s) required to restore this product to proper operating condition and an allowance for labor when provided by a FMI PRODUCTS, LLC Authorized Service Center or a provider approved by FMI PRODUCTS, LLC. Warranty parts must be obtained through authorized dealers of this product and/or FMI PRODUCTS, LLC who will provide original factory replacement parts. Failure to use original factory replacement parts voids this warranty.

Travel, handling, transportation, diagnostic, material, labor and incidental costs associated with warranty repairs, unless expressly covered by this warranty, are not reimbursable under this warranty and are the responsibility of the owner.

Excluded from this warranty are products or parts that fail or become damaged due to misuse, accidents, improper installation, lack of proper maintenance, tampering, or alteration(s).

This is FMI PRODUCTS, LLC's exclusive warranty, and to the full extent allowed by law; this express warranty excludes any and all other warranties, express or implied, written or verbal and limits the duration of any and all implied warranties, including warranties of merchantability and fitness for a particular purpose to four (4) years on new products and 30 days on factory reconditioned products from the date of first purchase. FMI PRODUCTS, LLC makes no other warranties regarding this product.

FMI PRODUCTS, LLC's liability is limited to the purchase price of the product, and FMI PRODUCTS, LLC shall not be liable for any other damages whatsoever under any circumstances including indirect, incidental, or consequential damages.

Some states do not allow limitations on how long an implied warranty lasts or the exclusion or limitation of incidental or consequential damages, so the above limitation or exclusion may not apply to you.

This warranty gives you specific legal rights, and you may also have other rights which vary from state to state.

For information about this warranty contact:

  
**FMI PRODUCTS, LLC**  
2701 S. Harbor Blvd.  
Santa Ana, CA 92704  
1-866-328-4537  
[www.fmiproducts.com](http://www.fmiproducts.com)

125078-01  
Rev. C  
02/12