



FMI PRODUCTS, LLC

INSTALLATION INSTRUCTIONS FOR NCDM-42VC CONVERSION KIT

**For Use When Converting Model (V)VC42P Series,
(V)VCC42P Series And CGCDV42PR Series
from Propane/LP Gas to Natural Gas**

This conversion kit must be installed by a qualified service agency.

Read these instructions completely before installing this conversion kit.

Before proceeding, make sure gas control valve is in the OFF position, all electrical power to the appliance is OFF, and fireplace is cool to the touch.

⚠ CAUTION: The gas supply shall be shut off prior to disconnecting the electrical power before proceeding with the conversion.

Parts included with this kit:

Part No.	Description	Qty.
116491-01	Instruction Sheet	1
108085-01	Pilot Orifice NG (51)	1
24874	Burner Orifice NG (32)	1
14593	Gas Valve Regulator NG	1
116477-11	Conversion Label, English	1
116478-11	Conversion Label, French	1
106080-01	Conversion Information Label	1
106739-01	Registration, Gas Conversion	1

Tools Required

- 7/8" Open End Wrench or Adjustable Wrench
- 3/4" Open End Wrench or Adjustable Wrench
- Torx T20 or Slotted Screwdriver
- 5/32" Allen Wrench
- #2 Short Phillips Screwdriver
- Thread Sealant (Resistant to Propane/LP)

ACCESSING FIREPLACE

The gas control valve and main burner orifice are located under the firebox floor of appliance and are accessed by removing the lower louver panel. The pilot orifice is located in the pilot burner and is accessed by opening the glass door and removing the logs.

Removing Louver Panels

Remove the top and bottom louver panels by simultaneously pulling both top end spring latches towards center of appliance until they are disengaged from locating holes (see Figure 1). Repeat for bottom spring latches and pull louvers outward. To install or replace items removed, simply reverse procedures above.

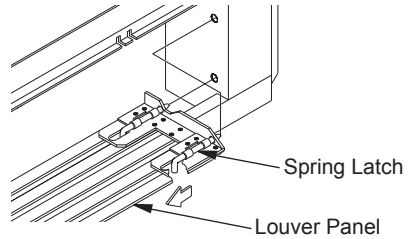

Figure 1 - Removing Louver Panel

Opening Glass Door

1. Remove screen assembly by pushing the rod either left or right and then down and forward. Set assembly aside.
2. Lift up on latches of door to unlock. There are two on top of firebox and two below firebox that hold glass door in place (see Figure 2).

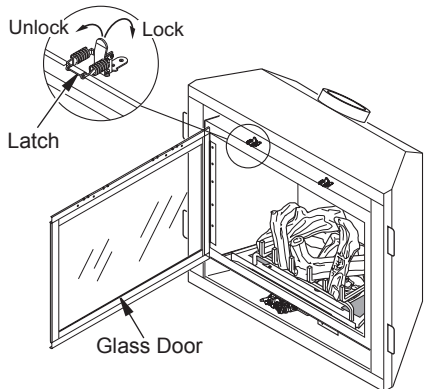

Figure 2 - Opening Glass Door

BURNER ORIFICE CONVERSION

1. Carefully remove logs/grate assembly by unscrewing grate from plenum (see Figure 3). The two logs under the grate are attached to the burner. **DO NOT** remove these logs.
2. Remove screws that attach the plenum to the burner to remove burner.
3. Remove main burner from grate base by removing four screws (see Figure 3).
4. Remove the LP orifice from elbow fitting. Apply a light amount of propane/LP resistant sealant to threaded end of NG orifice (#32) supplied with kit. Thread NG orifice into elbow and tighten.
5. Reinstall main burner to grate base with four screws removed in step 3.
6. Adjust air shutter to 3/16" open position.

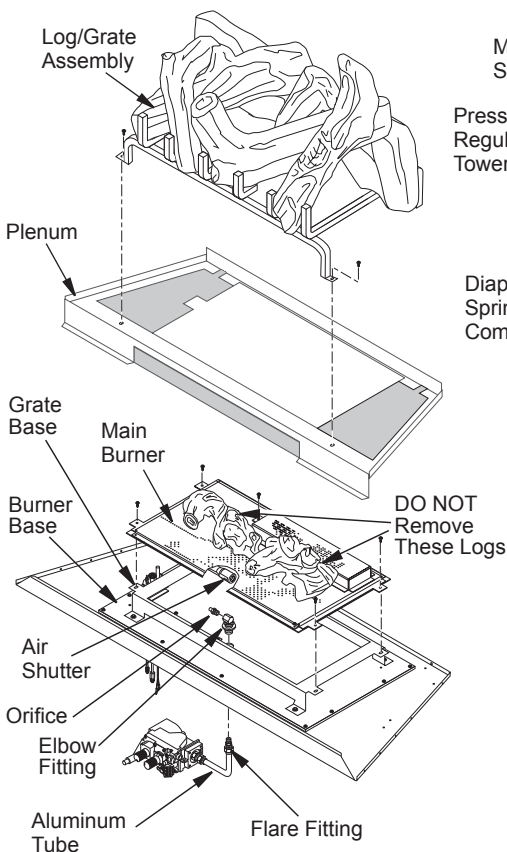

Figure 3 - Removing Orifice for Conversion (Valve Shown Removed from Base for Clarity)

GAS CONTROL VALVE CONVERSION

Convert the gas control valve by swapping out the valve regulator portion of the gas valve.

1. Using a Torx T20 or slotted screwdriver, remove and discard the three mounting screws, pressure regulator tower and diaphragm/spring components (see Figure 4).
2. Insure that the rubber gasket is properly positioned on the new pressure regulator assembly. Install the NG pressure regulator assembly to the valve using the new mounting screws supplied with the kit. Tighten screws securely (approximately 25 in-lbs.) (see Figure 5, page 3).
3. Install the identification label enclosed with the gas valve regulator to the valve body where it can easily be seen (see Figure 5, page 3).

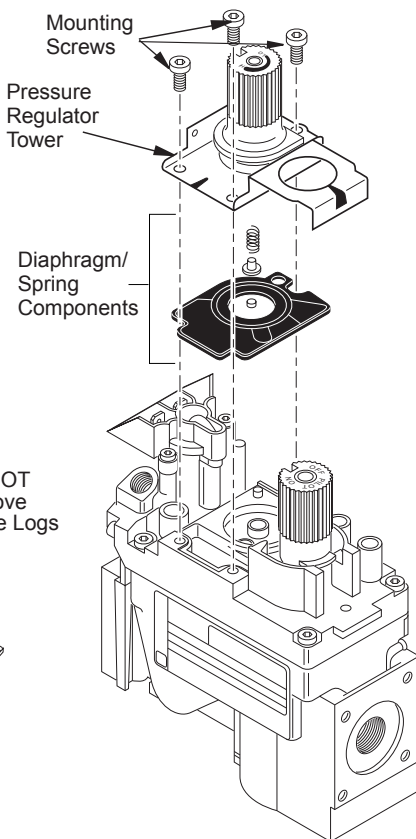

Figure 4 - Removing Mounting Screws, Pressure Regulator Tower and Diaphragm/Spring Components

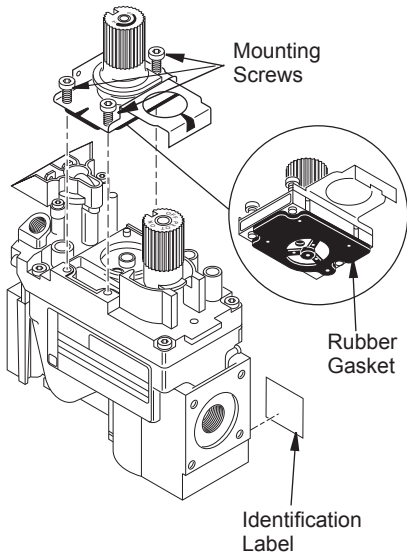

Figure 5 - Installing Pressure Regulator Assembly

CONVERSION LABELING AND PLACEMENT

1. Apply the English and French conversion labels over the top of existing certification labels (see Figure 6). Existing certification labels are located on the lighting instruction plate inside the gas valve compartment area. With permanent ink, print the previous model number on the label in the space provided (see Figure 7).
2. After filling in the data required on the conversion information label (see Figure 8), affix it to the floor of the appliance where it is easily seen when the lower door is removed.

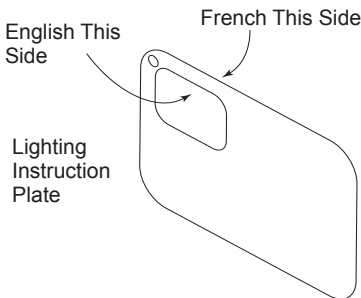

Figure 6 - Applying English and French Conversion Labels Over Existing Certification Labels on Lighting Instruction Plate

VENTED GAS FIREPLACE

Conversion Kit Model _____
 Type of Gas _____

PFS®

Previous Model # _____

Figure 7 - Print Previous Model Number on Conversion Labels

CONVERSION INFORMATION LABEL

This appliance was converted on _____
 _____ to _____ gas
 Day - Month - Year
 with Kit No. _____
 by _____

 (name and address of organization making this conversion), which accepts the responsibility that this conversion has been properly made.

56060 106080-01

Figure 8 - Conversion Information Label

PILOT ORIFICE CONVERSION

1. Remove the pilot hood by pulling up until it disengages from the barrel. Do not remove the retainer clip (see Figure 9, page 4).
2. Remove the pilot orifice from inside the barrel using a 5/32" allen wrench to unscrew the orifice.
3. Replace pilot orifice with NG orifice supplied with this kit. The number 51 is stamped on the sleeve for identification. Insert the small end of the new pilot orifice into the barrel and thread until tight with the allen wrench.
4. Line up the notch on pilot hood to the positioning tab on the barrel receiver and snap back into position.

IMPORTANT: Be careful not to bend or kink the aluminum tubing during conversion. Make sure the pilot hood and orifice are properly mated and aligned after finishing this conversion.

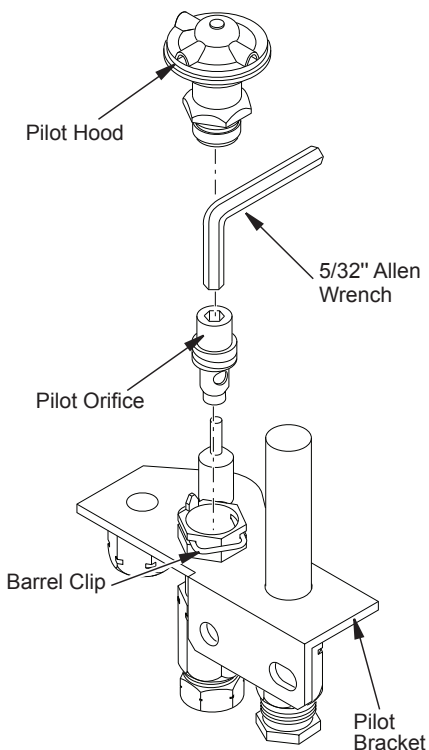

Figure 9 - Converting Pilot Orifice

FINAL PREPARATION

1. Reinstall the plenum to the burner and the log/grate assembly to the plenum with screws removed during *Burner Orifice Conversion* on page 2.
 2. Leak check the gas control and any connections you've made before operating the appliance. Refer to *Checking Gas Connections* in owner's manual.
 3. Close and latch door.
 4. Replace screen and reinstall louver panels.
- The conversion is now complete.

To operate your fireplace, refer to *Operating Fireplace* in your appliance owner's manual.

⚠ WARNING: Test all gas piping and connections, internal and external to unit, for leaks after installing or servicing. Correct all leaks at once.

⚠ WARNING: Never use an open flame to check for a leak. Apply noncorrosive leak detection fluid to all joints. Bubbles forming show a leak. Correct all leaks at once.

⚠ WARNING: This conversion kit shall be installed by a qualified service agency in accordance with the manufacturer's instructions and all applicable codes and requirements of the authority having jurisdiction. If the information in these instructions is not followed exactly, a fire, explosion or production of carbon monoxide may result causing property damage, personal injury or loss of life. The qualified service agency is responsible for the proper installation of this kit. The installation is not proper and complete until the operation of the converted appliance is checked as specified in the manufacturer's instructions supplied with this kit.