

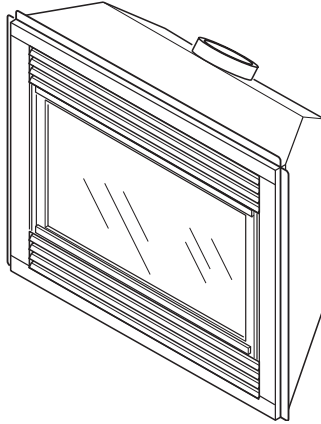

**DIRECT-VENT FIREPLACE
OWNER'S OPERATION AND INSTALLATION MANUAL**



**NATURAL GAS
CTDV36NR-A**

WARNING: If the information in this manual is not followed exactly, a fire or explosion may result causing property damage, personal injury or loss of life.

- Do not store or use gasoline or other flammable vapors and liquids in the vicinity of this or any other appliance.
- **WHAT TO DO IF YOU SMELL GAS**
 - Do not try to light any appliance.
 - Do not touch any electrical switch; do not use any phone in your building.
 - Immediately call your gas supplier from a neighbor's phone. Follow the gas supplier's instructions.
 - If you cannot reach your gas supplier, call the fire department.
- Installation and service must be performed by a qualified installer, service agency or the gas supplier.

INSTALLER: Leave this manual with the appliance
CONSUMER: Retain this manual for future reference.

TABLE OF CONTENTS

Safety Information	2	Cleaning and Maintenance.....	29
Local Codes.....	4	Troubleshooting	31
Product Identification.....	4	Replacement Parts.....	35
Product Features.....	4	Service Hints	35
Pre-Installation Preparation.....	5	Technical Service.....	35
Location of Termination Cap.....	7	Specifications	35
Venting Installation Instructions.....	8	Accessories	36
Fireplace Installation.....	18	Illustrated Parts Breakdown and Parts List.....	38
Operating Fireplace.....	26	Warranty Information	Back Cover
Inspecting Burners.....	29		

SAFETY INFORMATION

WARNING: Improper installation, adjustment, alteration, service or maintenance can cause injury or property damage. Refer to this manual for correct installation and operational procedures. For assistance or additional information consult a qualified installer, service agency or the gas supplier.

This appliance may be installed in an aftermarket,* permanently located, manufactured (mobile) home, where not prohibited by local codes.

This appliance is only for use with the type of gas indicated on the rating plate. This appliance is not convertible for use with other gases, unless a certified kit is used.

* Aftermarket: Completion of sale, not for purpose of resale, from the manufacturer

State of Massachusetts: The installation must be made by a licensed plumber or gas fitter in the Commonwealth of Massachusetts.

Installation and service must be performed by a qualified installer, service agency or the gas supplier.

 **WARNING:** This product contains and/or generates chemicals known to the State of California to cause cancer or birth defects, or other reproductive harm.

IMPORTANT: Read this owner's manual carefully and completely before trying to assemble, operate or service this fireplace. Improper use of this fireplace can cause serious injury or death from burns, fire, explosion, electrical shock and carbon monoxide poisoning.

 **DANGER:** Carbon Monoxide poisoning may lead to death.

SAFETY INFORMATION

Continued

This fireplace must be installed by a qualified (certified or licensed) service person. It has a sealed gas combustion chamber that uses a coaxial pipe (pipe within a pipe and having the same center) venting system. It brings in fresh air for combustion through the outer pipe and combustion gases are exhausted through the inner pipe. If the glass door assembly and venting pipe are not properly seated, connected, and sealed, carbon monoxide leakage (spillage) can occur.

Carbon Monoxide Poisoning: Early signs of carbon monoxide poisoning resemble the flu, with headaches, dizziness, or nausea. If you have these signs, the fireplace may not have been installed properly. **Get fresh air at once!** Have fireplace inspected and serviced by a qualified service person. Some people are more affected by carbon monoxide than others. These include pregnant women, people with heart or lung disease or anemia, those under the influence of alcohol, and those at high altitudes.

Propane/LP and Natural Gas: Propane/LP and natural gases are odorless. An odor-making agent is added to the gas. The odor helps you detect a gas leak. However, the odor added to the gas can fade. Gas may be present even though no odor exists.

Make certain you read and understand all warnings. Keep this manual for reference. It is your guide to safe and proper operation of this fireplace.

⚠ WARNING: Any change to this fireplace or its controls can be dangerous. Do not modify this fireplace under any circumstances. Any parts removed for servicing must be replaced prior to operating fireplace.

⚠ WARNING: This appliance is only for use with the type of gas indicated on the rating plate. This appliance is not convertible for use with other gases unless a certified kit is used.

⚠ WARNING: Do not use a blower insert, heat exchanger insert or other accessory not approved for use with this fireplace.

⚠ WARNING: Do not allow fans to blow directly into the fireplace. Avoid any drafts that alter burner flame patterns.

Due to high temperatures, the appliance should be located out of traffic and away from furniture and draperies.

Do not place clothing or other flammable material on or near the appliance. Never place any objects on the appliance.

Do not use this fireplace to cook food or burn paper or other flammable material.

This fireplace reaches high temperatures. Keep children and adults away from hot surface to avoid burns or clothing ignition. Fireplace will remain hot for a time after shutdown. Allow surface to cool before touching.

Carefully supervise young children when they are in the room with fireplace.

Keep the area around your fireplace clear of combustible materials, gasoline and other flammable vapor or liquids. Do not run fireplace where these are used or stored.

1. For propane/LP fireplace, do not place propane/LP supply tank(s) inside any structure. Locate propane/LP supply tank(s) outdoors. To prevent performance problems, do not use propane/LP fuel tank of less than 100 lbs. capacity.

SAFETY INFORMATION

Continued

- If you smell gas
 - shut off gas supply
 - do not try to light any appliance
 - do not touch any electrical switch; do not use any phone in your building
 - immediately call your gas supplier from a neighbor's phone. Follow the gas supplier's instructions
 - if you cannot reach your gas supplier, call the fire department.
- Never install the fireplace
 - in a recreational vehicle
 - in windy or drafty areas where curtains or other combustible (flammable) objects can make contact with the fireplace front
 - in high traffic areas
- Turn appliance off and let cool before servicing, installing or repairing. Only a qualified service person should install, service or repair this fireplace. Have fireplace inspected annually by a qualified service person.
- You must keep control compartments, burners and circulating air passages clean. More frequent cleaning may be needed due to excessive lint and dust from carpeting, bedding material, etc. Turn off the gas valve and pilot light before cleaning fireplace.
- Have venting system inspected annually by a qualified service person. If needed, have venting system cleaned or repaired.
- Do not use any solid fuels (wood, coal, paper, cardboard, etc.) in this fireplace.
- This appliance, when installed, must be electrically grounded in accordance with local codes or, in the absence of local codes, with the *National Electrical Code, ANSI/NFPA 70*.
- Do not use fireplace if any part has been exposed to or under water. Immediately call a qualified service person to arrange for replacement of the unit.
- Do not operate fireplace if any log is broken.
- Do not operate fireplace with glass door removed, cracked or broken.
- Provide adequate clearances around air openings.

LOCAL CODES

Install and use fireplace with care. Follow all local codes. In the absence of local codes, use the current *National Fuel Gas Code ANSI Z223.1/NFPA 54**.

*Available from:

American National Standards Institute, Inc.
1430 Broadway
New York, NY 10018

National Fire Protection Association, Inc.
Batterymarch Park
Quincy, MA 02269

PRODUCT IDENTIFICATION

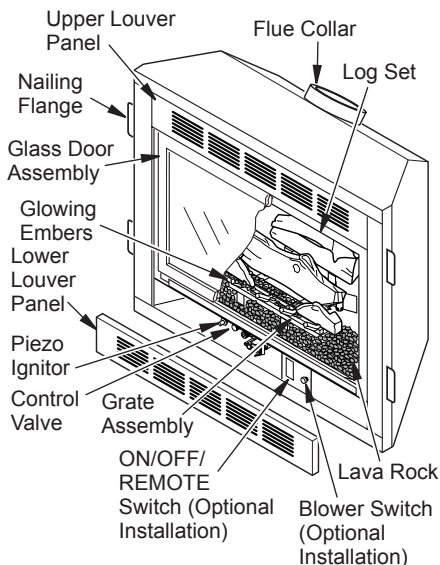

Figure 1 - Tudor Direct-Vent Fireplace with Millivolt Ignition

PRODUCT FEATURES

These are a few facts that can help you understand and enjoy your direct-vent fireplace:

- The venting system may be routed to the outside of your home in several ways. It may vent through the roof (vertical) or it may vent to an outside/exterior wall (horizontal). The vent pipe installation is very important to allow for proper operation. You must follow the venting instructions very carefully for either vertical or horizontal applications.
- This fireplace may be installed in any room of your house provided all local codes and these installation instructions are followed.

PRODUCT FEATURES

Continued

- This fireplace requires a wall switch, hand-held remote or wall thermostat (millivolt) for operation (see Accessories, page 36).
- This fireplace does not require electricity to operate.
- Only the blower requires electricity if installed and if you plan to install the blower at a later date, do not forget to wire the outlet at the bottom of the fireplace when framing.
- A piezo ignitor and ceramic electrode create spark to ignite the pilot light. It does not require any matches, batteries or any other sources of ignition to light the pilot.
- Each time you turn on your fireplace, you may notice some amount of condensation on the inside of the fireplace glass. This is normal and will disappear after 10-20 minutes of operation.
- Your direct-vent gas fireplace system (fireplace and venting) is a balanced and sealed gas operating unit. It requires approximately 10-20 minutes of operating time before the flame pattern stabilizes.

PRE-INSTALLATION PREPARATION

LOCATION AND SPACE REQUIREMENTS

Determine the safest and most efficient location for your FMI PRODUCTS, LLC direct-vent fireplace. Make sure that rafters and wall studs are not in the way of the venting system. Choose a location where the heat output is not affected by drafts, air conditioning ducts, windows or doors. Figure 2 shows some common locations. Be aware of all restrictions and precautions before deciding the exact location for your fireplace and termination cap.

When deciding the location of your fireplace, follow these rules:

- Do not connect this fireplace venting to a chimney flue serving a separate solid-fuel burning fireplace or appliance.
 - Due to high temperatures, do not locate this fireplace in high traffic areas, windy or drafty areas or near furniture or draperies.
 - Proper clearances must be maintained.
 - If your fireplace is to be installed directly on carpeting, vinyl tile or any combustible material other than wood, it must be installed on a metal or wood panel extending the full width and depth of the fireplace. See Figure 3.
- Your fireplace is designed to be used in zero clearance installations. Wall or framing material can be placed directly against any exterior surface on the back, sides or top of your fireplace, except where standoff spacers are integrally attached. If standoff spacers are attached to your fireplace, these spacers can be placed directly against wall or framing material. See framing details on page 6.
 - If you plan on installing a television or entertainment center recessed above your fireplace, it is recommended that you maintain a minimum 18" above top of louver opening.
 - When locating termination cap, it is important to observe the minimum clearances shown in Figure 7, page 7.
 - If recessing into a wall, you can avoid extra framing by positioning your fireplace against an already existing framing member.
 - Do not recess termination cap into a wall or siding.
 - You may paint the termination cap with 450° F (232° C) heat-resistant paint to coordinate with the exterior finish.
 - There must not be any obstruction such as bushes, garden sheds, fences, decks or utility buildings within 24" from the front of the termination cap.
 - Do not locate termination cap where excessive snow or ice build up may occur. Be sure to clear vent termination area after snow falls to prevent accidental blockage of venting system. When using snow blowers, do not direct snow towards vent termination area.

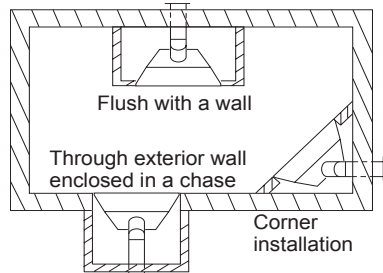

Figure 2 - Common Fireplace Locations

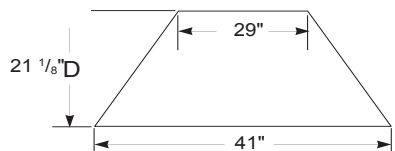

Figure 3 - Fireplace Bottom Dimensions

PRE-INSTALLATION PREPARATION

Continued

CLEARANCES

Minimum clearances to combustibles for the fireplace are as follows:

Back and sides	0"
Perpendicular walls	6"
Floor	0"
Ceiling to louver opening	42"
Front	36"
Top of Standoffs	0"

Vent (See venting instructions for specific venting clearances.)

Combustible material with a maximum thickness of 5/8" may be flush with the top front of fireplace.

NOTICE: This fireplace is intended for use as supplemental heat. Use this fireplace along with your primary heating system. Do not install this fireplace as your primary heat source. If you have a central heating system, you may run system's circulating blower while using fireplace. This will help circulate the heat throughout the house. In the event of a power outage, you can use this fireplace as a heat source.

FRAMING AND FINISHING

Figure 4 shows typical framing of this fireplace. Figure 5 shows framing for corner installation. All minimum clearances must be met.

For available accessories for this fireplace, see *Accessories* on page 36. If you are using a separate combustible mantel piece, refer to Figure 6 for proper installation height. You can install noncombustible mantels at any height above the fireplace.

Note: Noncombustible mantels may discolor!

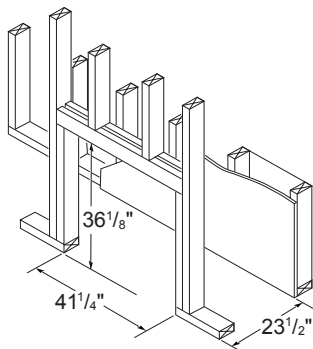

Figure 4 - Framing Clearances for Installation Against an Exterior Wall

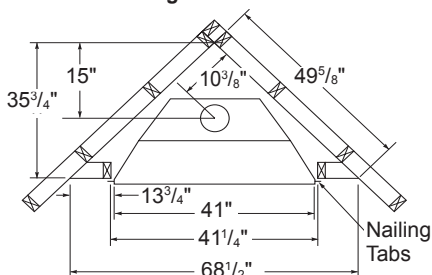
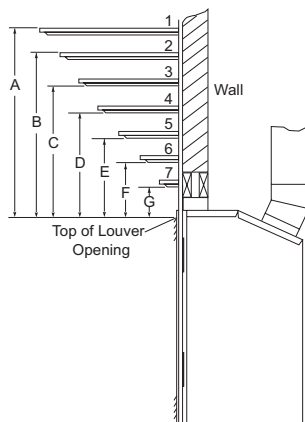

Figure 5 - Framing Clearances for Corner Installation



Ref.	Mantel Depth	Ref.	Mantel from Top of Louver Opening
1	14"	A	16"
2	12"	B	14"
3	10"	C	12"
4	8"	D	10"
5	6"	E	8"
6	4"	F	6"
7	2"	G	4"

Figure 6 - Clearances for Combustible Mantels

LOCATION OF TERMINATION CAP

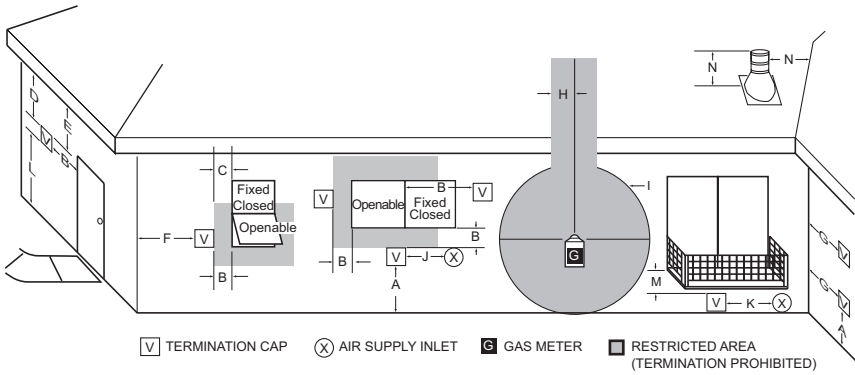

- A = clearance above grade, veranda, porch, deck, or balcony [*12" (30.5 cm) minimum]
- B = clearance to window or door that may be opened [12" (30.5 cm) minimum]
- C = clearance to permanently closed window [minimum 12" (30.5 cm) recommended to prevent condensation on window]
- D = vertical clearance to ventilated soffit located above the terminal within a horizontal distance of 24" (61 cm) from the center-line of the terminal [18" (45.7 cm) minimum]
- E = clearance to unventilated soffit [12" (30.5 cm) minimum]
- F = clearance to outside corner (see below)
- G = clearance to inside corner (see below)
- H = *not to be installed above a meter/regulator assembly within 36" (91.4 cm) horizontally from the center line of the regulator
- I = clearance to service regulator vent outlet [*72" (182.9 cm) minimum]
- J = clearance to non-mechanical air supply inlet to building or the combustion air inlet to any other fireplace [*12" (30.5 cm) minimum]
- K = clearance to a mechanical air supply inlet [*72" (182.9 cm) minimum]
- L = † clearance above paved side-walk or a paved driveway located on public property [*84" (213.3 cm) minimum]
- M = clearance under veranda, porch, deck [12" (30.5 cm) minimum ‡]
- N = clearance above a roof shall extend a minimum of 24" (61 cm) above the highest point when it passes through the roof surface and any other obstruction within a horizontal distance of 18" (45.7 cm)

† vent shall not terminate directly above a side-walk or paved driveway which is located between two single family dwellings and serves both dwellings*

‡ only permitted if veranda, porch, deck or balcony is fully open on a minimum of 2 sides beneath the floor*

* as specified in CAN/CSA B149 (.1 or .2) Installation Codes (1991) for Canada and U.S.A.

Note: Local codes or regulations may require different clearances

Termination Clearances for Buildings with Combustible and Noncombustible Exteriors

Inside Corner

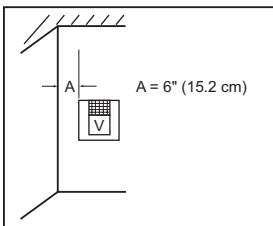

Outside Corner

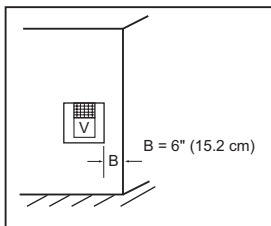

Recessed Location

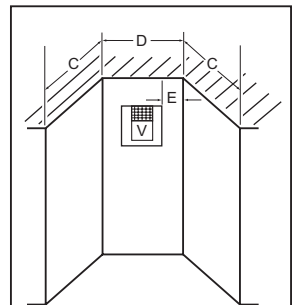

Balcony with No Side Wall

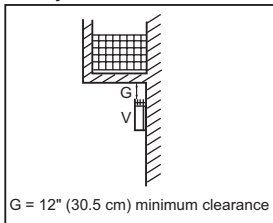

Balcony with Perpendicular Side Wall

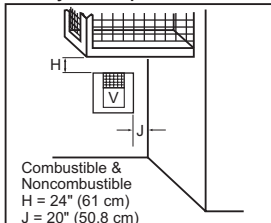

- C = Maximum depth of 48" (121.9 cm) for recessed location
- D = Minimum width for back wall of recessed location -
Combustible - 38" (965 mm)
Noncombustible - 24" (61 cm)
- E = Clearance from corner in recessed location-
Combustible - 6" (15.2 cm)
Noncombustible - 2" (5.1 cm)

Figure 7 - Minimum Clearances for Termination Cap

VENTING INSTALLATION INSTRUCTIONS

NOTICE: Read these instructions completely before attempting installation.

These models are tested and approved for use with FMI PRODUCTS, LLC (direct-vent) pipe components and terminations as well as Simpson-Duravent direct-vent pipe components and terminations.

The venting system must terminate on the outside of the structure and can not be attached to a chimney or flue system serving a separate solid fuel or gas burning appliance. A direct-vent appliance must have its own venting system. DO NOT common vent this appliance.

These models are approved to be vented either horizontally through an outside wall or vertically through a roof or chase enclosure using the following guidelines:

- When venting system terminates horizontally on an outside wall, you may install a standoff if the termination cap is to be installed directly on a combustible finish such as vinyl, wood, stucco, etc.
- Never run the vent downward as this may cause excessive temperatures which could cause a fire.
- Vent pipe air space clearances to combustibles are 1" on all sides except on the horizontal sections, which requires 2" clearance from the top of the pipe. Where the termination cap penetrates a combustible wall, 1" air space clearance is required.
- Snorkel terminations are required when minimum clearance to grade cannot be met (see Figure 16 on page 12).
- Have fireplace and selected vent components on hand to help determine the exact measurements when elbowing or offsetting. Always use wall firestops when penetrating walls and firestops when penetrating ceilings or attic spaces.
- If using a venting configuration of only horizontal venting with no vertical run, a 1/4" rise for every 12" of run toward the termination is required.

⚠ WARNING: Read all instructions completely and thoroughly before attempting installation. Failure to do so could result in serious injury, property damage or loss of life.

NOTICE: Failure to follow these instructions will void the warranty.

NOTICE: Do not seal termination cap to vent pipe. Cap must be removable for vent inspection and maintenance.

INSTALLATION PRECAUTIONS

- Wear gloves and safety glasses for protection
- Use extreme caution when using ladders or when on roof tops
- Be aware of electrical wiring locations in walls and ceilings

The following actions will void the warranty on your venting system:

- Installation of any damaged venting component
- Unauthorized modification of the venting system (Do not cut or alter vent components)
- Installation of any component part not manufactured or approved by FMI PRODUCTS, LLC
- Installation other than as instructed by these instructions

⚠ WARNING: This gas fireplace and vent assembly must be vented directly to the outside. The venting system must NEVER be attached to a chimney serving a separate solid fuel burning appliance. Each direct-vent gas appliance must use a separate vent system. Do not use common vent systems.

⚠ WARNING: Vent pipe air space clearances to combustibles are 1" on all sides except on the horizontal sections, which require 2" clearances from the top of the pipe. Where the termination cap penetrates a combustible wall, 1" air space clearance is required.

VENTING INSTALLATION INSTRUCTIONS

Continued

INSTALLATION PLANNING

There are two basic types of direct-vent installation:

- Horizontal Termination
- Vertical Termination

Horizontal Termination Installation

IMPORTANT: Horizontal square terminations require only inner portion of wall firestop. Horizontal installations using round termination require exterior portion of wall firestop available only in vent kit HTK (see Figure 14, page 11).

1. Set the fireplace in its desired location and determine the route your horizontal venting will take. Do not secure the fireplace until all venting has been installed. Some installations require sliding the fireplace in and out of position to make final venting connections. Figures 14 through 18 on pages 11 through 13 show different configurations for venting with horizontal termination that will help you decide which application best suits your installation. Check to see if wall studs or roof rafters are in the path of your desired venting route. If they are, you may want to adjust the location of the fireplace.
2. Direct vent pipe sections and components are designed with special twist-lock connections.

Twist-Lock Procedure: The female ends of the pipes have locking lugs (indentations). These lugs will slide straight into matching slots on the male ends of adjacent pipes. Push pipe sections together and twist one section clockwise approximately one-quarter turn until the sections are fully locked (see Figure 8). *Note:* Horizontal runs of vent must be supported every three feet. Use wall straps for this purpose.

3. Use a 45° elbow to connect venting system to fireplace flue collar. The elbow is designed to be twist-locked onto the flue collar as described in step 2. **IMPORTANT:** Do not attempt to alter the configuration of the elbow by cutting, twisting, bending, etc.
4. Assemble the desired combination of pipe and elbows to the fireplace flue collar. If there are long portions of venting run, pre-assembled pipe sections may be installed

as subassemblies for convenience.

5. Carefully determine the location where the vent pipe assembly will penetrate the outside wall. The center of the hole should line up with the center-line of the horizontal vent pipe. Mark the wall for a 10" x 10" square hole. Cut and frame the square hole in the exterior wall where the vent will be terminated. If the wall being penetrated is constructed of noncombustible material, such as masonry block or concrete, a 7 3/4" hole with zero clearance is acceptable (see Figure 9).

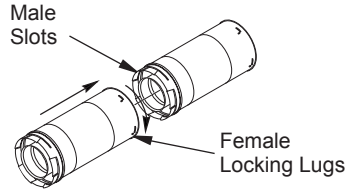

Figure 8 - Vent Pipe Connections

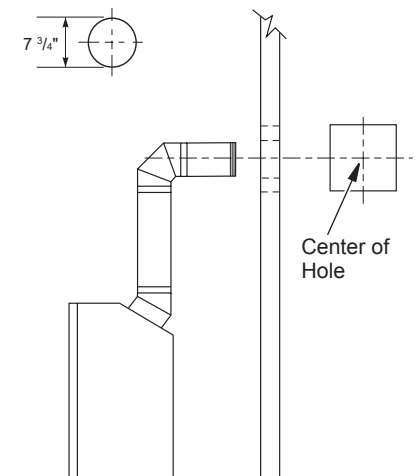
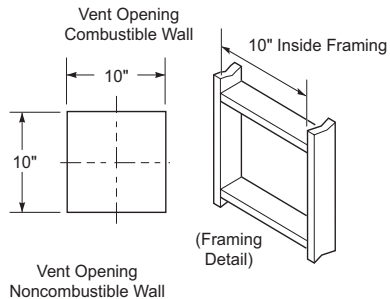

Figure 9 - Vent Opening Requirements

VENTING INSTALLATION INSTRUCTIONS

Continued

⚠ WARNING: Do not recess vent termination into any wall. This will cause a fire hazard.

6. **Noncombustible Exterior Wall:** Position the horizontal vent cap in the center of the 7 3/4" round hole and attach to the exterior wall with four wood screws provided. Before attaching the vent cap to exterior wall, run a bead of non-hardening mastic (pliable sealant) around the outside edges to make a seal between it and the outside wall. *Note:* The four wood screws provided should be replaced with appropriate fasteners for stucco, brick, concrete or other types of sidings.

Combustible Exterior Wall: For vinyl siding, stucco or wood exteriors, a siding standoff may be installed between the vent cap and exterior wall. The siding standoff prevents excessive heat from damaging the siding materials. Siding material must be cut to accommodate standoff. Bolt the vent cap to the standoff. Apply non-hardening mastic around outside edge of standoff. Position the standoff/cap assembly in the center of the 10" square hole and attach to exterior wall with wood screws provided (see Figure 11). The siding standoff must sit flush against the exterior fascia material.

7. **Combustible Exterior Wall Only:** Slide the wall firestop over the vent pipe before connecting horizontal run to vent cap (see Figure 12).
8. Carefully move fireplace, with vent assembly attached, toward wall and insert vent pipe into horizontal termination. The pipe overlap should be a minimum of 1 1/4" (see Figure 13, page 11).
9. **Combustible Exterior Wall Only:** Slide wall firestop against interior wall surface and attach with screws provided. See Figure 13, page 11, for horizontal termination details.
10. Place fireplace into position and shim with noncombustible material if needed. Nail or screw side flanges to framing to secure unit in place. **IMPORTANT:** Make sure fireplace is level before securing. If fireplace is not level it will not work properly.

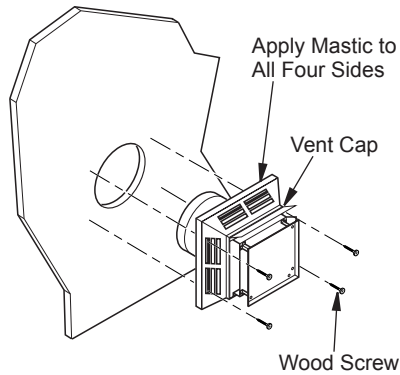

Figure 10 - Installing Horizontal Vent Cap (Noncombustible Exterior)

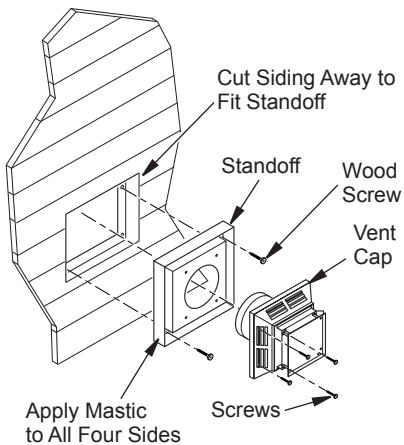

Figure 11 - Installing Siding Standoff (Combustible Exterior Wall)

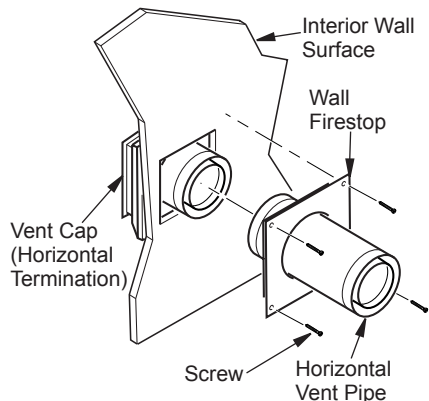

Figure 12 - Connecting Vent Cap with Horizontal Vent Pipe

VENTING INSTALLATION INSTRUCTIONS

Continued

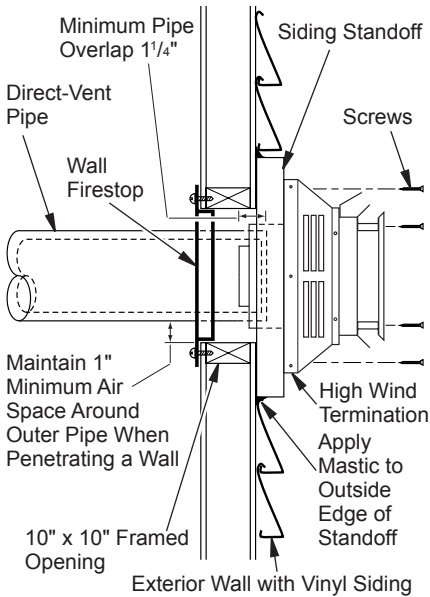

Figure 13 - Typical Horizontal Termination Cap Mounting with Additional Siding Standoff Installed

Horizontal Termination Configurations

Figures 14 through 18 show different configurations and alternatives for venting with horizontal termination. Each figure includes a chart with critical minimum and maximum dimensions which **MUST** be met. **IMPORTANT:** If using a venting configuration of only horizontal venting with no vertical run, a 1/4" rise for every 12" of run toward the termination is required.

NOTICE: Do not seal termination cap to vent pipe. Cap must be removable for vent inspection and maintenance.

WARNING: Never run vent downward as this may cause excessive temperatures which could cause a fire. Operation of improperly installed and maintained venting system could result in serious injury, property damage or loss of life.

GROUND FLOOR INSTALLATION

Recommended Applications:

- Installation using cabinet surrounds
- Through the wall using round or square termination (up to 12" horizontal pipe)
- **NOT FOR CORNER INSTALLATION**

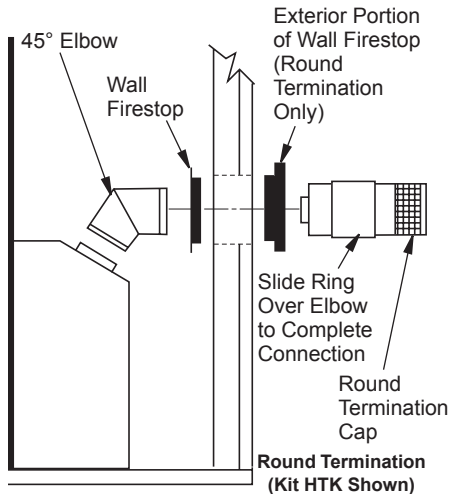
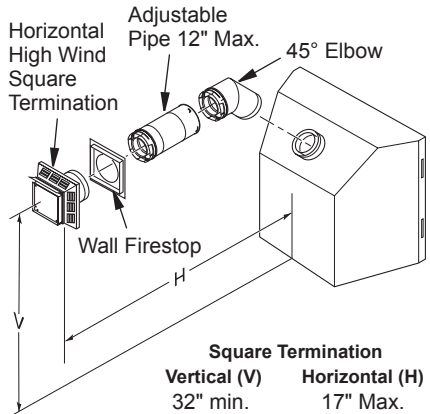

* If installing this fireplace at altitudes of 4000 feet and above, it is recommended that an additional vertical height of 6" be added to the vent system.

Figure 14 - Horizontal Termination Configuration for Square and Round Terminations

VENTING INSTALLATION INSTRUCTIONS

Continued

CORNER AND ALTERNATE INSTALLATION

Recommended Applications:

- Corner ground floor installation
- Ground floor installation where pipe vents horizontally through wall (over 12" horizontal pipe)
- Basement installation where one foot clearance from ground to termination is possible

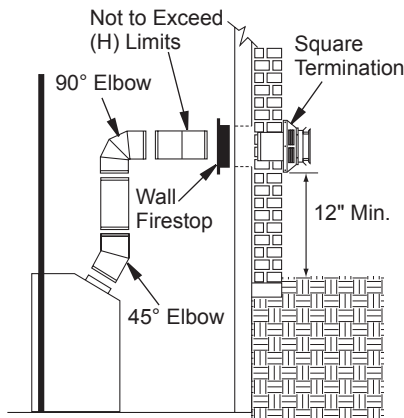
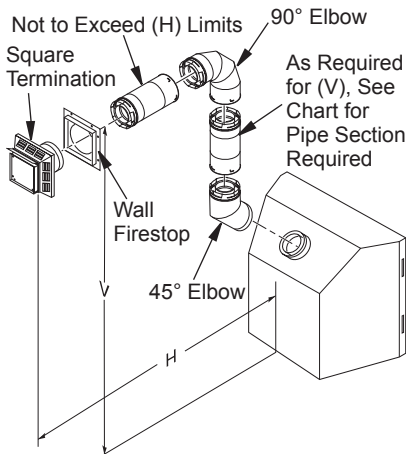

	Required	
Vertical (V)	Vertical Pipe	Horizontal (H)
*43 1/4" min.	None	30" max.
54 1/4" min.	1 ft.	48" max.
66 1/4" min.	2 ft.	60" max.
78 1/4" min.	3 ft.	84" max.
90 1/4" min.	4 ft.	20' max.

* Ground Floor Corner Venting

Figure 15 - Horizontal Termination Configuration for Corner Installation Using One 90° Elbow

SNORKEL TERMINATION INSTALLATION

Recommended Applications:

- Installations requiring a vertical rise on building exterior
- Any installation using snorkel termination to achieve one foot above ground

Snorkel terminations are available for installations requiring a vertical rise on the exterior of the building. If installing snorkel termination below grade, you must provide proper drainage to prevent water from entering snorkel termination (see Figure 16). Do not back fill around snorkel termination.

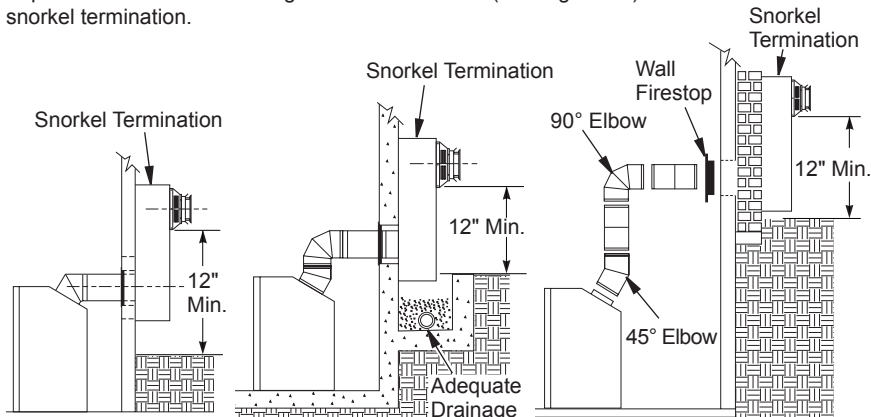

Figure 16 - Snorkel Termination Configurations for Below Ground Installation

VENTING INSTALLATION INSTRUCTIONS

Continued

HORIZONTAL SYSTEM INSTALLATION USING TWO 90° ELBOWS

The following configurations show the minimum vertical rise requirements for a horizontal system using two 90° elbows.

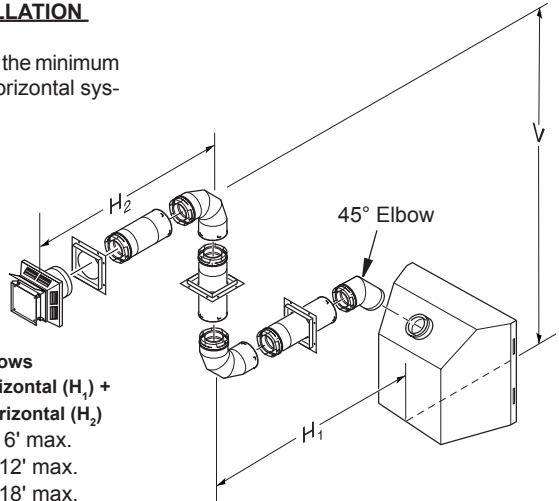

Venting with Two 90° Elbows

Vertical (V)	Horizontal (H ₁)	Horizontal (H ₁) + Horizontal (H ₂)
5' min.	2' max.	6' max.
6' min.	4' max.	12' max.
7' min.	6' max.	18' max.
8' min.	8' max.	20' max.
20' max.	8' max.	20' max.

Figure 17 - Horizontal Termination Configuration for Venting Using Two 90° Elbows

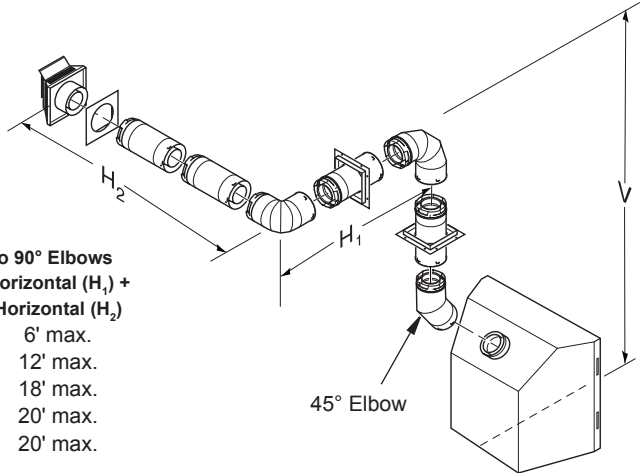

Vertical (V)	Horizontal (H ₁) + Horizontal (H ₂)
5' min.	6' max.
6' min.	12' max.
7' min.	18' max.
8' min.	20' max.
20' max.	20' max.

Figure 18 - Horizontal Termination Configuration for Venting Using Two 90° Elbows with Termination at 90° with Fireplace

VENTING INSTALLATION INSTRUCTIONS

Continued

INSTALLATION FOR VERTICAL TERMINATION

Note: Vertical restrictor must be installed in all vertical installations.

1. Determine the route your vertical venting will take. If ceiling joists, roof rafters or other framing will obstruct the venting system, consider an offset (see Figure 19) to avoid cutting load bearing members. *Note:* Pay special attention to these installation instructions for required clearances (air space) to combustibles when passing through ceilings, walls, roofs, enclosures, attic rafters, etc. Do not pack air spaces with insulation. Also note maximum vertical rise of the venting system and any maximum horizontal offset limitations.
2. Set the fireplace in desired location. Drop a plumb line down from the ceiling to the position of the fireplace exit flue. Mark the center point where the vent will penetrate the ceiling. Drill a small locating hole at this point.

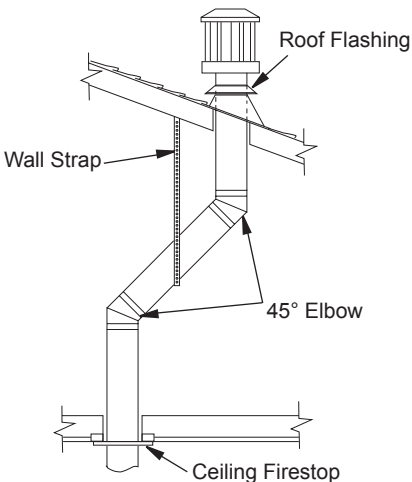

Figure 19 - Offset with Wall Strap and 45° Elbows

Drop a plumb line from the inside of the roof to the locating hole in the ceiling. Mark the center point where the vent will penetrate the roof. Drill a small locating hole at this point.

Flat Ceiling Installation

1. Cut a 10" square hole in the ceiling using the locating hole as a center point. The opening should be framed to 10" x 10" inside dimensions, as shown in Figure 9 on page 9 using framing lumber the same size as the ceiling joists. If the area above the ceiling is an insulated ceiling or attic space, nail firestop from the top side. This prevents loose insulation from falling into the required clearance space. If the area above the ceiling is a living space, install firestop below the framed hole. The firestop should be installed with no less than three nails per side (see Figure 20).
2. Assemble the desired lengths of pipe and elbows necessary to reach from the fireplace flue up through the firestop. Be sure all pipe and elbow connections are fully twist-locked (see Figure 8, page 9).
3. Cut a hole in the roof using the locating hole as a center point. (Cover any exposed open vent pipes before cutting hole in roof.) The 10" x 10" hole must be measured on the horizontal; actual length may be larger depending on the pitch of the roof. There must be a 1" clearance from the vent pipe to combustible materials. Frame the opening as shown in Figure 9, page 9.

If area above is an attic or insulated area, install firestop above framed hole.

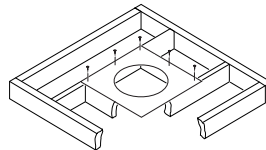

If area above is a living space, install firestop below framed hole.

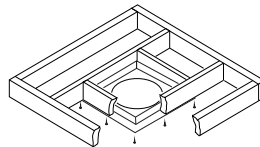

Figure 20 - Installing Firestop

VENTING INSTALLATION INSTRUCTIONS

Continued

4. Connect a section of pipe and extend up through the hole.

Note: If an offset is needed to avoid obstructions, you must support the vent pipe every 3 feet. Use wall straps for this purpose (see Figure 19, page 14). Whenever possible, use 45° elbows instead of 90° elbows. The 45° elbow offers less restriction to the flow of the flue gases and intake air.

5. Place the flashing over the pipe section(s) extending through the roof. Secure the base of the flashing to the roof and framing with roofing nails. Be sure roofing material overlaps the top edge of the flashing as shown in Figure 19, page 14. There must be a 1" clearance from the vent pipe to combustible materials.

6. Continue to add pipe sections until the height of the vent cap meets the minimum building code requirements described in Figure 7 on page 7. *Note:* You must increase vent height for steep roof pitches. Nearby trees, adjoining rooflines, steep pitched roofs and other similar factors may cause poor draft or down-drafting in high winds. Increasing the vent height may solve this problem.

7. Twist-lock the vent cap onto the last section of vent pipe.

Note: If the vent pipe passes through any occupied areas above the first floor, including storage spaces and closets, you must enclose pipe. You may frame and sheetrock the enclosure with standard construction material. Make sure and meet the minimum allowable clearances to combustibles. Do not fill any of the required air spaces with insulation.

Vertical Termination Configurations

Figures 21 through 24 show four different configurations for vertical termination.

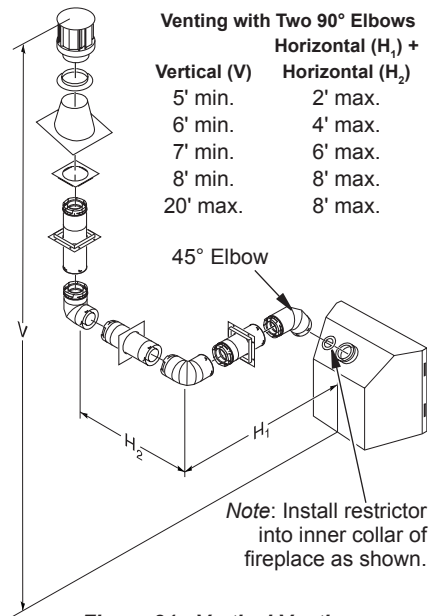

Figure 21 - Vertical Venting Configuration Using Two 90° Elbows with Two Horizontal Runs (Vertical Round High Wind Termination Shown)

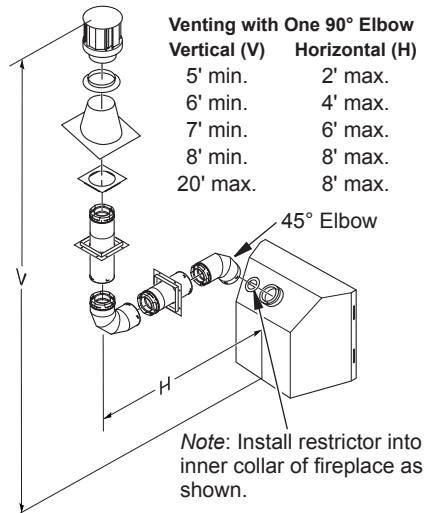
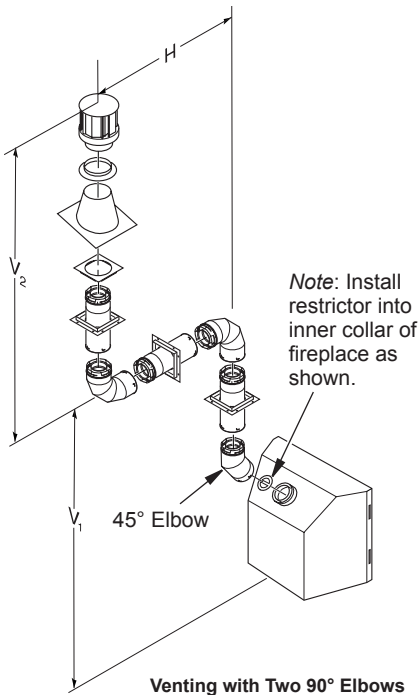

Figure 22 - Vertical Venting Configuration Using One 90° Elbow (Vertical Round High Wind Termination Shown)

VENTING INSTALLATION INSTRUCTIONS

Continued



Venting with Two 90° Elbows

Vertical (V_1)	Horizontal (H)
5' min.	6' max.
6' min.	12' max.
7' min.	18' max.
8' min.	20' max.

Note: Vertical (V_1) + Vertical (V_2) = 40' max.

Figure 23 - Vertical Venting Configuration Using Two 90° Elbows (Vertical Round High Wind Termination Shown)

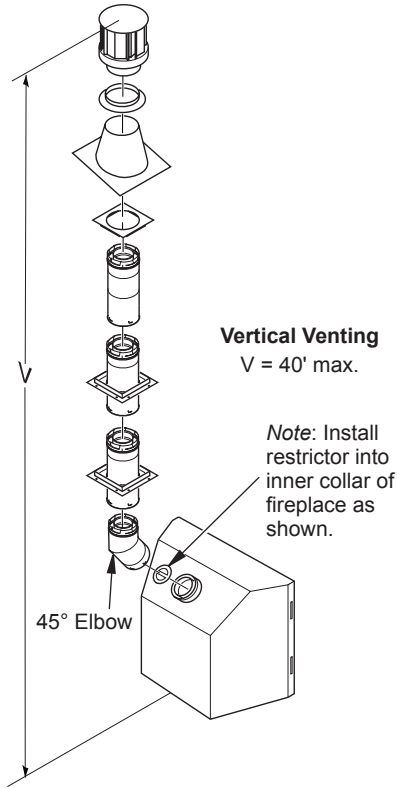

Figure 24 - Vertical Venting Configuration With No Horizontal Run (Vertical Round High Wind Termination Shown)

HIGH ALTITUDE INSTALLATION

Your FMI PRODUCTS, LLC direct-vent fireplace has been tested and approved for elevations from 0-2,000 feet.

When installing this fireplace at an elevation above 2,000 feet, you may need to decrease the input rating by changing the existing burner orifice to a smaller size. Reduce input 4% for each 1,000 feet above sea level. Check with your local gas company for proper orifice size identification.

Consult your local gas company to help determine the proper orifice for your location.

For assistance with any high altitude installation, contact FMI PRODUCTS, LLC's Customer Service Department at 1-866-328-4537.

VENTING INSTALLATION INSTRUCTIONS

Continued

PARTS LIST FOR VENTING KITS AND COMPONENTS

FMI PRODUCTS, LLC Pipe & Vent Kits

<u>Number</u>	<u>Description</u>
P47-6	6" Section Coaxial Pipe, Galvanized
P47-12	12" Section Coaxial Pipe, Galvanized
P47-24	24" Section Coaxial Pipe, Galvanized
P47-36	36" Section Coaxial Pipe, Galvanized
P47-48	48" Section Coaxial Pipe, Galvanized
PA47-712	Adjustable 7"-12" Section Coaxial Pipe, Galvanized
VKG-47	Ground Floor Vent Kit, Galvanized (Includes: 45° Elbow, 7"-12" Adjustable Pipe, Wall Firestop, Horizontal Square Termination, 16 Screws)
VKB-47	Basement Vent Kit, Galvanized (Includes: 45° Elbow, 7"-12" Adjustable Pipe, Wall Firestop, Horizontal Square Termination, 4' Pipe, 90° Elbow, 20 Screws)
VKS-47	Snorkel Vent Kit, Galvanized (Includes: 45° Elbow, 7"-12" Adjustable Pipe, Wall Firestop, 36" Snorkel Termination, 4' Pipe, 1' Pipe, 90° Elbow, 26 Screws)
VKR-47	Roof Vent Kit, Galvanized (Includes: 45° Elbow, 7"-12" Adjustable Pipe, Flue Restrictor, Vertical High Wind Termination, 2' Pipe, 4' Pipe, Wall Firestop, Storm Collar, Roof Flashing [0/12 - 6/12], 26 Screws)
VKC-47	Corner Vent Kit, Galvanized (Includes 45° Elbow, 7"-12" Adjustable Pipe, Wall Firestop, Horizontal Termination, 6" Pipe, 90° Elbow, 18 Screws)

<u>Number</u>	<u>Description</u>
HTK	Horizontal Round Termination Kit (Includes: Round Termination, Wall Firestop and 45° Elbow)
HTKS-47	Horizontal Square Termination Kit (Includes: Square Termination, Wall Firestop, 45° Elbow)

FMI PRODUCTS, LLC Elbows

<u>Number</u>	<u>Description</u>
E47-45	45° Elbow, Galvanized
E47-90	90° Elbow, Galvanized

FMI PRODUCTS, LLC Terminations

<u>Number</u>	<u>Description</u>
HT-47	Horizontal Round Termination, Galvanized
HTS-47	Horizontal Square Termination, Galvanized
VT-47	Vertical Round Termination, Galvanized
ST-47-14	14" Snorkel Termination, Galvanized
ST-47-36	36" Snorkel Termination, Galvanized

FMI PRODUCTS, LLC Venting Accessories

<u>Number</u>	<u>Description</u>
SC-47	Storm Collar, Galvanized
WF-47	Wall Firestop, Galvanized
RF-47-6	Roof Flashing - 0 to 6/12 Pitch, Galvanized
RF-47-12	Roof Flashing - 6/12 to 12/12 Pitch, Galvanized
VR-47	Vertical Restrictor, Galvanized
S-47	Combustible Siding Standoff, Galvanized
WS-47	Wall Strap
FP-47	Firestop Plate

FIREPLACE INSTALLATION

CHECK GAS TYPE

Use proper gas type for fireplace unit you are installing. If your gas supply is not correct, do not install fireplace. See retailer where you purchased the fireplace for proper fireplace according to your gas type or to purchase gas conversion kit (see *Accessories*, page 36). A conversion kit is supplied with the CTDV36NR-A.

INSTALLING OPTIONAL BLOWER ACCESSORIES

NOTICE: If installing blower in an existing fireplace with gas connections, shut off gas supply and disconnect heater from gas supply. Contact a qualified service person to do this.

WARNING: If there is a duplex electrical outlet installed in the right side of the bottom of the fireplace base area, be sure that the electrical power to the outlet is turned off before proceeding with blower installation. Failure to do this may result in serious injury.

Model BK Installation

Follow all instructions provided in blower accessory kit.

1. Attach the power cord to blower motor by firmly pushing two female terminals at end of power cord onto two spade terminals on blower motor (see Figure 25).
2. Attach green ground wire from power cord to blower housing using screw provided (see Figure 25). Tighten screws securely.
3. Place blower against lower rear wall of firebox outer wrapper with exhaust port directed upward. The blower will fit inside back opening and be held in position against back wall by magnets (see Figure 25).
4. Be certain that all wire terminals are securely attached to terminals on blower motor and screw retaining green ground wire is tight.
5. Mount speed control box to switch bracket by placing plastic control shaft forward through opening in switch bracket (see Figure 26).

6. While supporting speed control, secure control shaft with lock nut by pushing and turning lock nut with pliers clockwise until it is tight against front panel. Place control knob provided on shaft.
7. Turn on power to duplex outlet if previously turned off per the warning above.
8. Plug in blower power cord.
 - a. If your firebox is installed as a free-standing unit with an accessory mantel, determine whether power cord will exit left side or right side of firebox. Route power cord through exit hole and plug power cord into a wall receptacle near firebox.
 - b. If your firebox installation is recessed and/or pre-wired, plug power cord into duplex outlet provided. Refer to your firebox owner's manual for instructions on wiring duplex outlet.

CAUTION: Never touch the blower wheel while in operation.

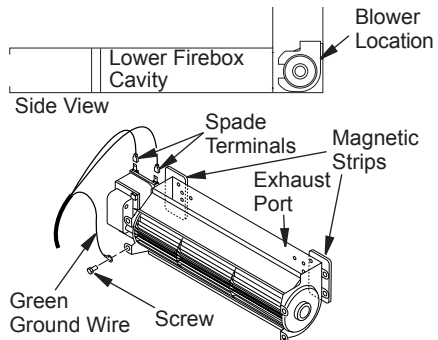

Figure 25 - Blower Model BK

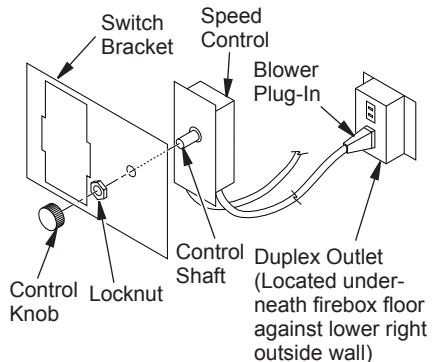

Figure 26 - Attaching Speed Control to Firebox

FIREPLACE INSTALLATION

Continued

9. Check to make sure power cord is completely clear of blower wheel and there are no other foreign objects in blower wheel. Turn blower on and check for operation. Turn blower off by turning knob fully counterclockwise before continuing.
10. Peel off backing paper and stick supplied wiring diagram decal on firebox bottom approximately 12" in front of blower (see Figure 27).

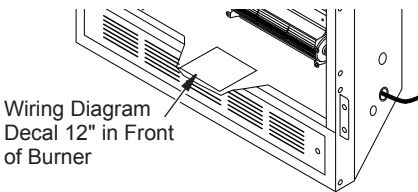

Figure 27 - Location of Wiring Diagram Decal (Model May Vary from Illustration)

Model BKT Installation

Note: When installing BKT thermostatically-controlled blower, you must first secure thermal switch bracket to blower if it has not already been factory installed.

1. Place green ground wire with ring terminal between bottom hole on thermal switch bracket and top ear hole on blower assembly. Insert phillips screw into all three pieces and tighten securely (see Figure 28).
2. Connect wire harness and power cord terminals. Connect blue jumper wire to blower motor terminal and right side terminal of thermal switch. Connect black wire to left side of thermal switch and white wire to other remaining blower motor terminal.

Note: Power cord outer insulation sleeve may have to be stripped slightly to allow enough wire length to reach and make all connections. DO NOT trim excessive length away. Just enable enough to make all connections securely.

3. Place blower against lower rear wall of firebox outer wrapper with exhaust port directed upward and thermodisc positioned up near fireplace bottom. Thermodisc must be oriented near fireplace bottom as shown in Figure 28 in order to sense temperature and properly operate. Blower will be held in position against back wall by magnets incorporated onto blower housing (see Figure 28).
4. Be certain that all wire terminals are securely

attached to terminals on blower motor and thermal switch, and that screw for thermodisc bracket and green ground wire is tight.

5. Mount speed control box against mounting plate provided in lower fireplace cavity by placing plastic control shaft forward through round hole (see Figure 26, page 18).
6. While supporting speed control, secure control shaft with lock nut by pushing and turning lock nut with pliers clockwise until it is tight against mounting plate. Place control knob provided on shaft (see Figure 26, page 18).
7. Check to make sure power cord is completely clear of blower wheel and that no other foreign objects are in blower wheel. Also double check all wire leads and make sure wire routing is not pinched or in a precarious position. Correct accordingly.
8. Turn on power to duplex outlet if previously turned off per warning in column 1, page 18.
9. Plug in blower power cord to duplex outlet.
10. Blower will only run when speed control knob is in ON position and thermal switch senses temperature after fireplace begins to heat up. Blower speed can be adjusted by rotating control knob. To turn off, turn knob fully counterclockwise until it clicks off. If blower is ON and has been running with fireplace operating, blower will continue to run for a short time after fireplace has been turned off. As thermal switch cools down, blower shuts down automatically.

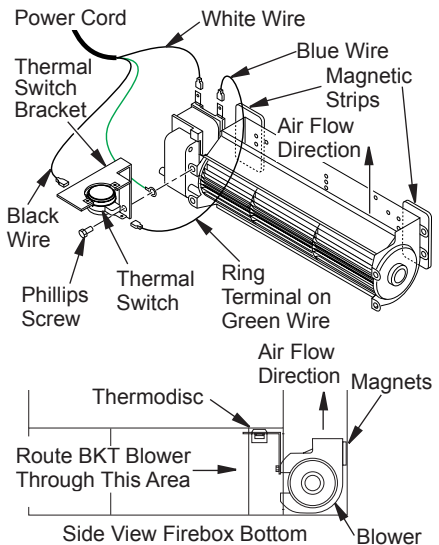

Figure 28 - Blower Model BKT

FIREPLACE INSTALLATION

Continued

- Peel off backing paper and stick supplied wiring diagram decal on firebox bottom approximately 12" in front of blower (see Figure 27, page 19).

Blower Wiring Diagram

CAUTION: Label all wires prior to disconnection when servicing controls. Wiring errors can cause improper and dangerous operation. Verify proper operation after servicing.

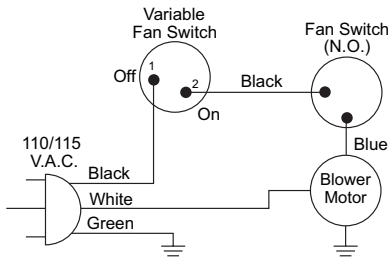

Figure 29 - Blower Wiring Diagram for Thermostat-Controlled Models

INSTALLING GAS PIPING TO FIREPLACE LOCATION

WARNING: A qualified service person must connect fireplace to gas supply. Follow all local codes.

CAUTION: For propane/LP units, never connect fireplace directly to the propane/LP supply. This heater requires an external regulator (not supplied). Install the external regulator between the fireplace and propane/LP supply.

WARNING: For natural gas, never connect heater to private (non-utility) gas wells. This gas is commonly known as wellhead gas.

Installation Items Needed

Before installing fireplace, make sure you have the items listed below.

- external regulator (supplied by installer)
- piping (check local codes)
- sealant (resistant to propane/LP gas)
- equipment shutoff valve *
- test gauge connection *
- sediment trap
- tee joint
- pipe wrench
- approved flexible gas line with gas connector (if allowed by local codes)

* A equipment shutoff valve with 1/8" NPT tap is an acceptable alternative to test gauge connection. Purchase the equipment shutoff valve from your retailer.

For propane/LP connection only, the installer must supply an external regulator. The external regulator will reduce incoming gas pressure. You must reduce incoming gas pressure to between 11" and 14" of water. If you do not reduce incoming gas pressure, fireplace regulator damage could occur. Install external regulator with the vent pointing down as shown in Figure 30. Pointing the vent down protects it from freezing rain or sleet.

CAUTION: Use only new, black iron or steel pipe. Internally-tinned copper tubing may be used in certain areas. Check your local codes. Use pipe of 1/2" inside diameter or greater to allow proper gas volume to fireplace. If pipe is too small, undue loss of volume will occur.

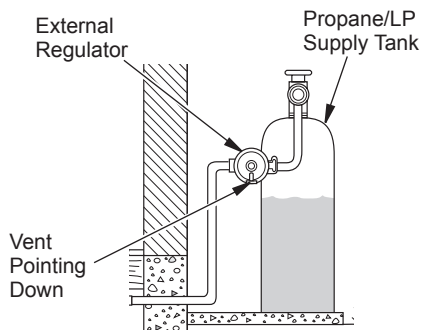

Figure 30 - External Regulator with Vent Pointing Down (Propane/LP Only)

FIREPLACE INSTALLATION

Continued

Installation must include an equipment shutoff valve, union, and plugged 1/8" NPT tap. Locate NPT tap within reach for test gauge hook up. NPT tap must be upstream from fireplace (see Figure 31).

IMPORTANT: Install main gas valve (equipment shutoff valve) in an accessible location. The main gas valve is for turning on or shutting off the gas to the appliance.

Check your building codes for any special requirements for locating equipment shutoff valve to fireplaces.

Apply pipe joint sealant lightly to male NPT threads. This will prevent excess sealant from going into pipe. Excess sealant in pipe could result in clogged fireplace valves.

⚠ WARNING: Use pipe joint sealant that is resistant to liquid petroleum (LP) gas.

We recommend that you install a sediment trap/drip leg in supply line as shown in Figure 31. Locate sediment trap/drip leg where it is within reach for cleaning. Install in piping system between fuel supply and fireplace. Locate sediment trap/drip leg where trapped matter is not likely to freeze. A sediment trap traps moisture and contaminants. This keeps them from going into fireplace gas controls. If sediment trap/drip leg is not installed or is installed wrong, fireplace may not run properly.

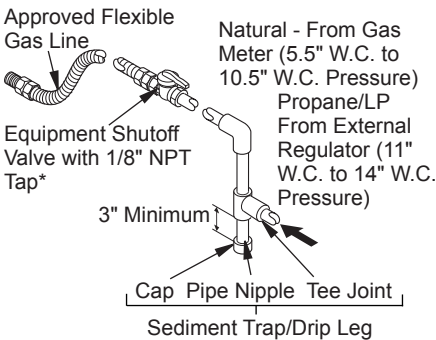

Figure 31 - Gas Connection

* The shutoff valve may be supplied with the appliance or you can purchase it from your retailer.

CONNECTING FIREPLACE TO GAS SUPPLY

Installation Items Needed

- 5/16" hex socket wrench or nut-driver
- sealant (resistant to propane/LP gas, not provided)

1. Open lower louver door panel by gently pulling forward.
2. Route flexible gas line (provided by installer) from equipment shutoff valve to fireplace. Route flexible gas supply line through one of the access holes on side of fireplace.
3. Attach flexible gas line from gas supply to control valve (see Figure 32).
4. Check all gas connections for leaks. See *Checking Gas Connections*.

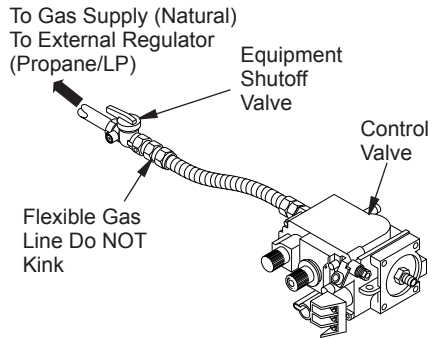

Figure 32 - Connecting Flexible Gas Line to Control Valve

CHECKING GAS CONNECTIONS

⚠ WARNING: Test all gas piping and connections, internal and external to unit, for leaks after installing or servicing. Correct all leaks at once.

⚠ WARNING: Never use an open flame to check for a leak. Apply a noncorrosive leak detection fluid to all joints. Bubbles forming show a leak. Correct all leaks at once.

FIREPLACE INSTALLATION

Continued

PRESSURE TESTING GAS SUPPLY PIPING SYSTEM

Test Pressures In Excess Of 1/2 PSIG (3.5 kPa)

1. Disconnect fireplace and its individual equipment shutoff valve from gas supply piping system. Pressures in excess of 1/2 psig (3.5 kPa) will damage fireplace gas regulator.
2. Cap off open end of gas pipe where equipment shutoff valve was connected.
3. Pressurize supply piping system by either opening propane/LP supply tank valve for propane/LP gas fireplace or opening main gas valve located on or near gas meter for natural gas fireplace, or using compressed air.
4. Check all joints of gas supply piping system. Apply noncorrosive leak detection fluid to all joints. Bubbles forming show a leak. Correct all leaks at once.
5. Reconnect fireplace and equipment shutoff valve to gas supply. Check reconnected fittings for leaks.

Test Pressures Equal To or Less Than 1/2 PSIG (3.5 kPa)

1. Close equipment shutoff valve (see Figure 33).
2. Pressurize supply piping system by either opening propane/LP supply tank valve for propane/LP gas fireplace or opening main gas valve located on or near gas meter for natural gas fireplace, or using compressed air.
3. Check all joints from propane/LP supply

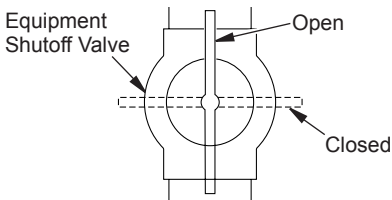
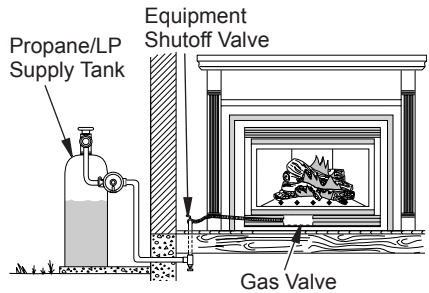
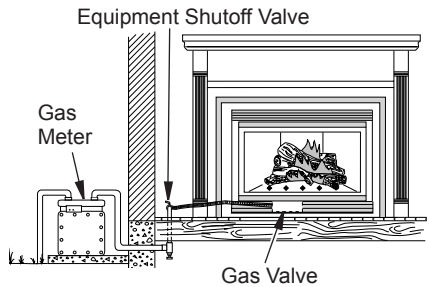

Figure 33 - Equipment Shutoff Valve



**Figure 34 - Checking Gas Joints for
Propane/LP Gas Fireplace**



**Figure 35 - Checking Gas Joints for
Natural Gas Fireplace**

tank or gas meter to equipment shutoff valve (see Figure 34 or 35). Apply noncorrosive leak detection fluid to all joints. Bubbles forming show a leak. Correct all leaks at once.

PRESSURE TESTING FIREPLACE GAS CONNECTIONS

1. Open equipment shutoff valve (see Figure 33).
2. Open main gas valve located on or near gas meter for natural gas or open supply tank valve for propane/LP gas.
3. Make sure control knob of fireplace is in the OFF position.
4. Check all joints from equipment shutoff valve to thermostat gas valve (see Figure 34 or 35). Apply noncorrosive leak detection fluid to all joints. Bubbles forming show a leak. Correct all leaks at once.
5. Light fireplace (see *Operating Fireplace*, page 27). Check all other internal joints for leaks.
6. Turn off fireplace (see *To Turn Off Gas to Appliance*, page 27).

FIREPLACE INSTALLATION

Continued

INSTALLING OPTIONAL WALL MOUNT SWITCH - GWMS2

1. Connect one terminal of 25 ft. wire for wall switch to TPTH terminal on the valve. Connect remaining wire terminal to the TH terminal on the valve. Make sure wire terminals are in positions on unit as pictured in Figure 36. If wires are not connected as shown, switch will not work.
2. Route 25 ft. wire through openings provided on sides of burner system to a convenient location to mount your switch.
3. Connect one bare wire end to each terminal of GWMS wall switch.
4. Install wall switch and cover in the wall.

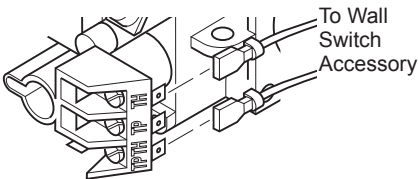

Figure 36 - Connecting Wall Switch to Control Valve

REMOVING/REPLACING GLASS DOOR

CAUTION: Do not operate this fireplace with a broken glass door panel or without the glass door panel securely in place. For replacement part information see *Replacement Parts*, page 35.

CAUTION: Wear gloves and safety glasses while handling or removing broken glass. Do not remove if glass is hot. Keep children and pets away from glass.

WARNING: If fireplace has been running, turn off and unplug fireplace. Let cool before removing glass door or louvers.

Removing Louver Panels

Remove the top and bottom louver panels by simultaneously pulling both top end spring latches towards the center of the appliance until they are disengaged from the locating holes (see Figure 37). Repeat for bottom spring latches and pull the louvers outward. To install or replace items removed, simply reverse the procedures above.

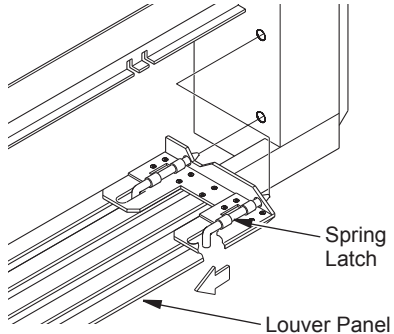

Figure 37 - Removing Louver Panel

Removing Glass Door

If replacement of glass is necessary, the entire assembly, glass and frame, must be replaced. If glass is broken, wear gloves and tape the remaining fragments onto the frame.

1. Remove screen assembly by pushing the rod either left or right and then down and forward to remove screen/rod assembly from the firebox. Set assembly aside.
2. Lift up on latches to unlock. There are two on top of firebox and two below firebox that hold glass door in place (see Figure 38, page 24).
3. While holding glass door to prevent it from falling and causing injury, remove the five screws from the hinge located on the left side of door frame assembly (see Figure 38, page 24).
4. Remount the new frame at the hinge with five new screws before closing door. This will ensure seating of the gasket.
5. Close glass door frame. Lock latches by placing the bar under the tab on door and pushing down and back on latch (see Figure 38, page 24).
6. Replace screen/rod assembly by reversing step 1.
7. Replace louvers by reversing procedure under *Removing Louver Panels*.

FIREPLACE INSTALLATION

Continued

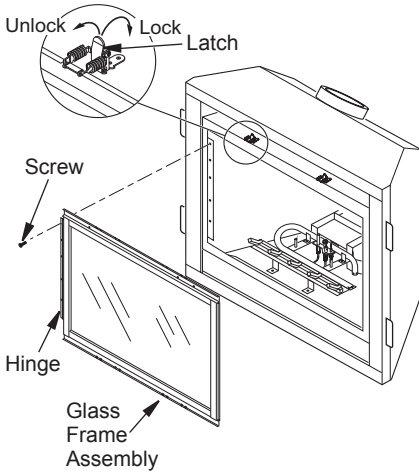

Figure 38 - Removing/Replacing Glass Door

Cleaning Glass Door

See *Cleaning and Maintenance* on page 29.

INSTALLING OPTIONAL BRICK LINER MODELS BL36D-A(S-A) AND BL36DHA(S-A)

WARNING: If fireplace has been running, turn off and unplug fireplace. Let cool before installing brick liner.

This brick liner kit is optional. You may purchase brick liner from your local retailer or see *Accessories*, page 36.

CAUTION: Always handle brick panels with two hands. Do not force brick panels into place. Excessive force will break brick panels.

1. Remove top and bottom louvers to allow access to door latches.
2. Remove screen, unlock door latches and open glass door. See *Removing/Replacing Glass Door*, steps 1 and 2, page 23.
3. If installing brick liner in new fireplace, go to step 4. If installing brick liner in an existing fireplace, carefully remove logs, lava rock, and ember material.

4. Remove three screws from deflector shield on inside top of firebox. Set shield and screws aside.
5. Install rear brick panel first. Rest bottom edge of panel on back edge of grate (see Figure 39).

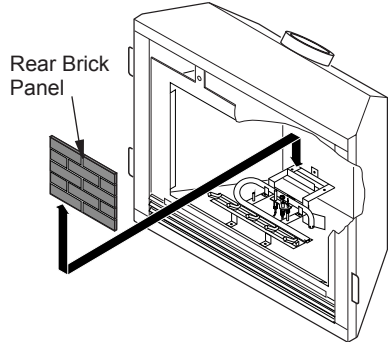

Figure 39 - Installing Rear Brick Panel

6. Install left side brick panel by sliding it between grate and side of firebox (see Figure 40).
7. Install the right brick panel using the same method described
8. Replace deflector shield using screws removed in step 4.
9. Install logs, lava rock, and ember material see *Installing Logs, Lava Rock and Glowing Embers*.
10. Close glass door, lock latches on top and bottom of door and replace screen (see *Removing/Replacing Glass Door*, steps 5 and 6, page 23).

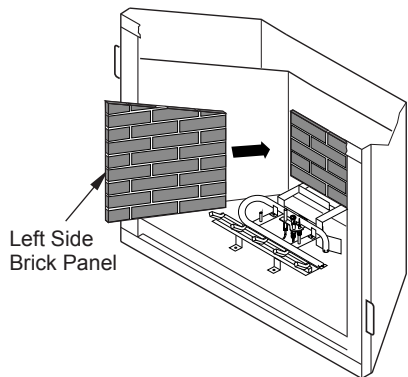

Figure 40 - Installing Side Brick Panels

11. Close top and bottom louvers.

FIREPLACE INSTALLATION

Continued

INSTALLING LOGS, LAVA ROCK AND GLOWING EMBERS

It is very important to install these logs exactly as instructed. Do not modify logs. Only use logs supplied with fireplace.

Open louvers, remove screen, unlock door latches, and open glass door. See *Removing/Replacing Glass Door*, steps 1 and 2, page 23. Install logs according to instructions for fireplace model numbers.

1. Find and place log #1 (rear log) on top of grate. Make sure notches in bottom of log fit over grate (see Figure 41).

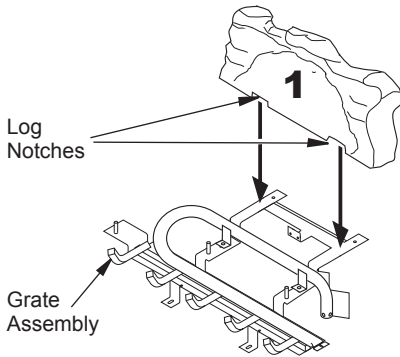

Figure 41 - Installing Log No. 1

2. Rest log #2 (front log) on pins on front part of grate (see Figure 42).

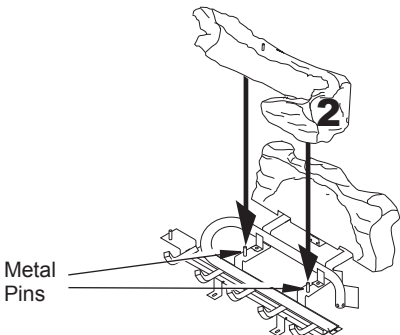

Figure 42 - Installing Log No. 2

3. Place log #3 (crossover log) onto rear and front logs. Make sure it is seated properly on surface of rear log and pin on front log as shown in Figure 43.

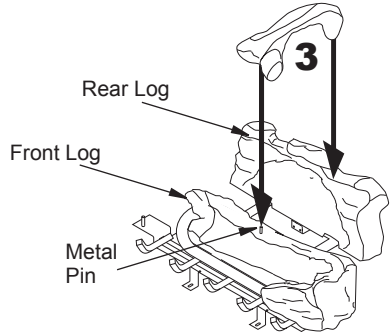

Figure 43 - Installing Log No. 3

4. Place log #4 (right log) onto log landing on right side of front log as shown in Figure 44.

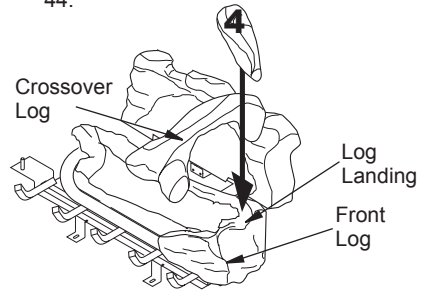

Figure 44 - Installing Log No. 4

5. Place log #5 (base log) onto front left part of grate making sure notch and hole fit over metal pin and prong of grate. See Figure 45.
6. Place log #6 (left log) onto rear log landing and resting it on top of front log. See Figure 45.

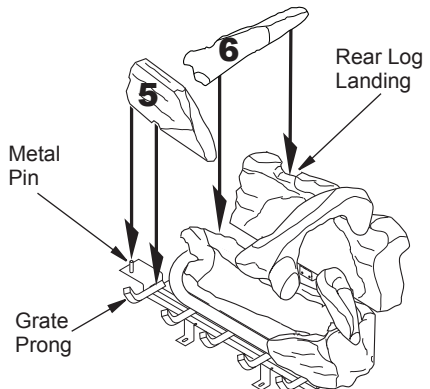

Figure 45 - Installing Logs No. 5 and No. 6

FIREPLACE INSTALLATION

Continued

- Place lava rock along sides and front of firebox bottom in areas that are visible only. It is not necessary to use all of lava rock provided.

NOTICE: Do not put lava rock on burner or under burner. Placing lava rock on burner will cause performance problems.

- Pull ember material apart into pieces no larger than a dime. Place these pieces loosely and sparingly directly onto exposed section of front burner and along space between burner and grate prongs (see Figure 46). This will create glowing ember appearance as flame touches ember material. Do not block air slots by using too much ember material in one area. It is not necessary to use all of ember material provided.

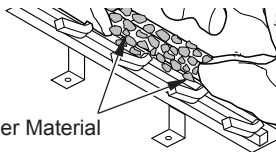

Figure 46 - Placing Ember Material on Burner

- Close glass door, lock door latches, replace screen and close louvers (see *Removing/Replacing Glass Door*, steps 5 through 7, page 23).

WARNING: The glass door must be securely in place before running this fireplace. Do not run this fireplace if glass is missing or broken.

OPERATING FIREPLACE

**FOR YOUR SAFETY
READ BEFORE LIGHTING**

WARNING: If you do not follow these instructions exactly, a fire or explosion may result causing property damage, personal injury or loss of life.

- This appliance is equipped with an ignition device which automatically lights the pilot. Do not try to light by hand.
- BEFORE LIGHTING** smell all around the appliance area for gas. Be sure to smell next to the floor because some gas is heavier than air and will settle on the floor.
WHAT TO DO IF YOU SMELL GAS
 - Do not try to light any appliance.
 - Do not touch any electric switch; do not use any phone in your building.
 - Immediately call your gas supplier from a neighbor's phone. Follow the gas supplier's instructions.
- Use only your hand to push in or turn the gas control knob. Never use tools. If the knob will not push in or turn by hand, don't try to repair it, call a qualified service technician. Force or attempted repair may result in a fire or explosion.
- Do not use this appliance if any part has been under water. Immediately call a qualified service technician to inspect the appliance and to replace any part of the control system and any gas control which has been under water.

**LIGHTING
INSTRUCTIONS**

NOTICE: During initial operation of new heater, burning logs will give off a paper-burning smell. Orange flame will also be present. Open damper or window to vent smell. This will only last a few hours.

OPERATING FIREPLACE

Continued

1. STOP! Read the safety information, above.
2. Open lower louver panel.
3. Turn off all electric power to the fireplace.
4. Push in gas control knob slightly and turn clockwise to OFF.
5. Wait five (5) minutes to clear out any gas. Then smell for gas, including near the floor. If you smell gas, STOP! Follow "B" in the safety information in column 1. If you don't smell gas, go to the next step.
6. The pilot is located by the main burner and should not require accessing for lighting.
7. Turn gas control knob counterclockwise to PILOT.
8. Push in gas control knob all the way and hold. Immediately light pilot by repeatedly depressing piezo spark igniter until a flame appears. Continue to hold for about 1 minute after pilot is lit. Release gas control knob and it will pop back. Pilot should remain lit. If it goes out, repeat steps 5 through 8.
9. Turn on all electric power to the fireplace.
10. Turn gas control knob counterclockwise to ON.
11. This valve is equipped with a HI/LO feature. Set fireplace input as desired.
12. Close lower louver panel.

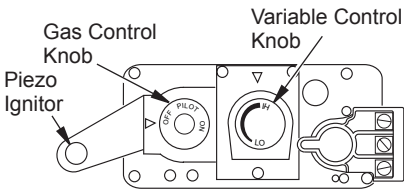

Figure 47 - Control Valve

TO TURN OFF GAS TO APPLIANCE

1. Open lower louver panel.
2. Set selector switch in the OFF position to prevent draining battery.
3. Turn off all electrical power to the appliance if service is to be performed.
4. Push in gas control knob slightly and turn clockwise to OFF.
5. Close lower louver panel.

Shutting Off Burners Only (pilot stays lit)
You may shut off the burners and keep the pilot lit by doing one of the following:

1. Turn gas control knob clockwise to the PILOT position.
2. Set selector switch in the OFF position.

MANUAL LIGHTING PROCEDURE

1. Remove glass door (see *Removing/Replacing Glass Door*, page 23.)
2. Follow steps 1 through 7 under Lighting Instructions, page 26.
3. Depress gas control knob and light pilot with match.
4. Keep gas control knob pressed in for 30 seconds after lighting pilot. After 30 seconds, release gas control knob. Follow steps 9 through 12 under *Lighting Instructions*, page 26.
5. Replace glass door (see *Removing/Replacing Glass Door*, page 23).

OPTIONAL HAND-HELD REMOTE OPERATION

Note: All remote control accessories must be purchased separately (see *Accessories*, page 36). Follow instructions included with the remote control.

NOTICE: You must light the pilot before using the hand-held remote control unit. See *Lighting Instructions*, page 26.

OPERATING FIREPLACE

Continued

After lighting, let pilot flame burn for about one minute. Turn control knob to ON position. Adjust flame adjustment knob anywhere between HI and LO. Slide the selector switch to the REMOTE position (see Figure 48). Note: The burner may light if hand-held remote was on when selector switch was last turned off. You can now turn the burner on and off with the hand-held remote control unit.

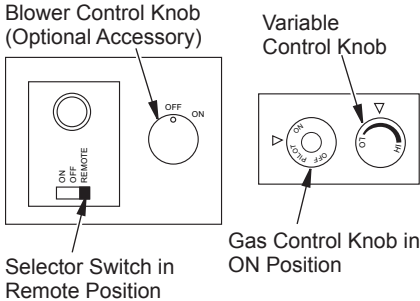

Figure 48 - Setting the Selector Switch, Gas Control Knob and Variable Control Knob for Remote Operation

IMPORTANT: Do not leave the selector switch in the REMOTE or ON position when the pilot is not lit. This will drain the battery.

OPERATING OPTIONAL GWMT1 WALL MOUNTED THERMOSTAT

WARNING: Do not connect the thermostat to a power source. Electrical shock and/or a fire hazard will occur.

Light the fireplace as instructed in *Lighting Instructions on page 26*. Set wall thermostat to desired temperature.

This thermostat has been electronically calibrated at the factory and requires no adjustment or leveling.

Upon installation, the thermostat must be allowed to stabilize at room temperature for a minimum of 30 minutes for proper operation.

To turn the fireplace off, adjust thermostat to the lowest setting and turn the gas

control knob back to PILOT. The pilot will remain lit.

IMPORTANT: To turn the pilot off, turn the gas control knob on the heater to the OFF position.

OPERATING OPTIONAL BLOWER ACCESSORY

Locate the blower controls by opening the lower louver panel on the fireplace. Blower controls are located on the left side of the switch bracket to the left just inside the louver panel.

The BK manual blower and the BKT thermostatically-controlled blower have an ON setting and an OFF setting. The blower will only run when the switch is in the ON position. In the OFF position, the blower will not operate.

Note for BKT Only: If you are using BKT blower with optional thermostat (wall mounted or remote control) for the fireplace, your fireplace and blower will not turn on and off at the same time. The fireplace may run for several minutes before the blower turns on. After the heater modulates to the pilot position, the blower will continue to run. The blower will shut off after the firebox temperature decreases.

The blower helps distribute heated air from the fireplace. Periodically check the louvers of the firebox and remove any dust, dirt, or other obstructions that will hinder the flow of air.

INSPECTING BURNERS

Check pilot flame pattern and burner flame patterns often.

PILOT ASSEMBLY

The pilot assembly is factory preset for the proper flame. Alterations may have occurred during shipping and handling. The pilot is located on the back right hand side of the burner.

The flame must envelope 1/4" of top of the ignitor/sensor and grounding stem.

If your pilot assembly does not meet these requirements:

- Turn the adjustment screw marked PILOT clockwise to decrease or counterclockwise to increase the flame to proper size (see Figure 49). Do not remove the adjustment screw.
- see *Troubleshooting*, page 31

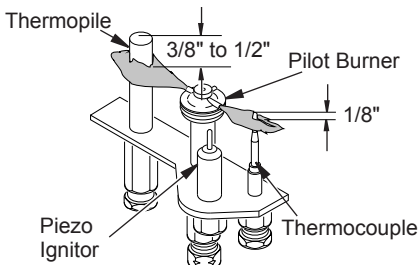

Figure 49 - Pilot Assembly

BURNER FLAME PATTERN

Burner flames will be steady; not lifting or floating. Flame patterns will be different from unit to unit and will vary depending on installation type and weather conditions.

If the vent configuration is installed incorrectly, the flames will lift or "ghost". This can be dangerous. Inspect the flames after installation to ensure proper installation and performance.

Figure 55 shows a typical flame pattern.

If burner flame pattern differs from that described:

- turn fireplace off (see *To Turn Off Gas to Appliance*, page 27)
- see *Troubleshooting*, page 31



Figure 50 - Typical Flame Pattern

CLEANING AND MAINTENANCE

⚠ WARNING: Turn off fireplace and let cool before cleaning.

⚠ CAUTION: You must keep control areas, burners, and circulating air passageways of fireplace clean. Inspect these areas of fireplace before each use. Have fireplace inspected yearly by a qualified service person. Fireplace may need more frequent cleaning due to excessive lint from carpeting, bedding material, pet hair, etc.

GLASS DOOR

⚠ WARNING: Handle glass door panel with care. Do not strike, slam, or otherwise abuse glass. Do not operate fireplace with the glass door removed, cracked, or broken.

⚠ WARNING: Do not use abrasive cleaners as this may damage glass. Use a nonabrasive household glass cleaner to clean glass. Do not clean glass when hot.

Glass must be cleaned periodically. During start-up it is normal for condensation to form on the inside of the glass causing lint, dust, and other airborne particles to cling to the glass surface. During initial start-up a slight film may form on the glass due to paint curing. The glass should be cleaned several times with a non-ammonia, nonabrasive household cleaner and warm water after the first two weeks of operation. Thereafter, clean the glass two or three times during each heating season, depending on the usage and circumstances present. Refer to *Removing/Replacing Glass Door* on page 23 of this manual when removing glass door for cleaning.

CLEANING AND MAINTENANCE

Continued

 **WARNING:** Only parts supplied by the manufacturer should be used when replacing broken or damaged glass door panel (see *Replacement Parts*, page 35). This glass door panel is a complete unit. No substitute materials may be used.

 **CAUTION:** Wear gloves and safety glasses while handling or removing broken glass. Do not remove if glass is hot. Keep children and pets away from glass.

If glass has been broken, carefully remove glass door (see *Removing/Replacing Glass Door*, page 23). Vacuum all glass pieces with a shop vac.

 **CAUTION:** Do not vacuum if pieces are hot.

Use only the tempered glass door replacement intended for this fireplace (see *Replacement Parts*, page 35, for detail on ordering). No substitutions may be made. See *Removing/Replacing Glass Door*, page 23, for instructions for replacing glass door.

 **WARNING:** Do not operate fireplace with the glass door removed, cracked, or broken.

PILOT AND BURNERS

- Remove ember material before cleaning burners and replace when cleaning is complete.
- Burner and controls should be cleaned with compressed air to remove dust, dirt, or lint.
- Use a vacuum cleaner or small, soft bristled brush to remove excess dust, dirt, or lint.

LOGS

- If you remove logs for cleaning, refer to *Installing Logs, Lava Rock, and Glowing Embers*, page 25, to properly replace logs.
- Use a vacuum cleaner to remove any carbon buildup on logs.
- Replace log(s) if broken. See *Replacement Parts* on page 35.
- Replace ember material periodically as needed. See *Replacement Parts* on page 35.

VENTING SYSTEM

Conduct annual inspection of the venting system following these guidelines:

1. Check areas of venting system that are exposed to the weather for corrosion (rust spots or streaks and, in extreme cases, holes). Have these items replaced immediately by a qualified service person.
2. Remove the vent cap and shine a flashlight into the vent. Remove any foreign material.
3. Check for evidence of excessive condensation. Continuous condensation can cause corrosion of caps, pipes, and fittings and can be caused by having excessive lateral runs, too many elbows, or exterior portions of the system being exposed to cold weather.
4. Inspect joints to verify that no pipe section or fitting has been disturbed and loosened. Check mechanical supports such as wall straps for rigidity.

TROUBLESHOOTING

⚠ WARNING: Turn off heater and let cool before servicing. Only a qualified service person should service and repair heater.

⚠ CAUTION: Never use a wire, needle, or similar object to clean pilot. This can damage pilot unit.

Note: All troubleshooting items are listed in order of operation.

OBSERVED PROBLEM	POSSIBLE CAUSE	REMEDY
When ignitor button is pressed, there is no spark at pilot	<ol style="list-style-type: none"> 1. Ignitor electrode not connected to ignitor cable 2. Ignitor cable pinched or wet 3. Piezo ignitor nut is loose 4. Broken ignitor cable 5. Bad piezo ignitor 6. Ignitor electrode broken 7. Ignitor electrode positioned wrong 	<ol style="list-style-type: none"> 1. Reconnect ignitor cable 2. Free ignitor cable if pinched by any metal or tubing. Keep ignitor cable dry 3. Tighten nut holding piezo ignitor. Nut is located behind the mounting bracket 4. Replace ignitor cable 5. Replace piezo ignitor 6. Replace pilot assembly 7. Replace pilot assembly
When ignitor button is pressed, there is spark at pilot but no ignition	<ol style="list-style-type: none"> 1. Gas supply turned off or equipment shutoff valve closed 2. Gas control knob not in PILOT position 3. Gas control knob not pressed in while in PILOT position 4. Air in gas lines when in-stalled 5. Depleted gas supply (propane/LP models only) 6. Pilot is clogged 7. Gas regulator setting is not correct 	<ol style="list-style-type: none"> 1. Turn on gas supply or open equipment shutoff valve 2. Turn gas control knob to PILOT position 3. Press in gas control knob while in PILOT position 4. Continue holding down control knob. Repeat igniting operation until air is removed 5. Contact local propane/LP gas company 6. Clean pilot (see <i>Cleaning and Maintenance</i>, page 29) or replace pilot assembly 7. Replace gas control

TROUBLESHOOTING

Continued

OBSERVED PROBLEM	POSSIBLE CAUSE	REMEDY
Pilot lights but flame goes out when control knob is released	<ol style="list-style-type: none">1. Gas control knob not fully pressed in2. Gas control knob not pressed in long enough3. Equipment shutoff valve not fully open4. Pilot flame not touching thermocouple, which allows thermocouple to cool, causing pilot flame to go out. This problem could be caused by one or both of the following: A) Low gas pressure B) Dirty or partially clogged pilot5. Thermocouple connection loose at control valve6. Thermocouple damaged7. Control valve damaged	<ol style="list-style-type: none">1. Press in gas control knob fully2. After pilot lights, keep gas control knob pressed in 30 seconds3. Fully open equipment shutoff valve4. A) Contact local natural or propane/LP gas company B) Clean pilot (see <i>Cleaning and Maintenance</i>, page 29) or replace pilot assembly5. Hand tighten until snug, then tighten 1/4 turn more6. Replace pilot assembly7. Replace control valve
Burner does not light after pilot is lit	<ol style="list-style-type: none">1. Burner orifice clogged2. Inlet gas pressure is too low3. Thermopile leads disconnected or improperly connected4. Thermopile is defective	<ol style="list-style-type: none">1. Clean burner (see <i>Cleaning and Maintenance</i>, page 29) or replace burner orifice2. Contact local propane/LP or natural gas company3. Reconnect leads4. Replace thermopile
Delayed ignition burner	<ol style="list-style-type: none">1. Manifold pressure is too low2. Burner porting or orifice clogged	<ol style="list-style-type: none">1. Contact local propane/LP or natural gas company2. Clean burner (see <i>Cleaning and Maintenance</i>, page 29) or replace burner orifice
Burner backfiring during combustion	<ol style="list-style-type: none">1. Burner orifice is clogged or damaged2. Damaged burner3. Gas regulator defective	<ol style="list-style-type: none">1. Clean burner (see <i>Cleaning and Maintenance</i>, page 29) or replace burner orifice2. Replace damaged burner3. Replace gas control
Slight smoke or odor during initial operation	<ol style="list-style-type: none">1. Residues from manufacturing processes and logs curing	<ol style="list-style-type: none">1. Problem will stop after a few hours of operation

TROUBLESHOOTING

Continued

OBSERVED PROBLEM	POSSIBLE CAUSE	REMEDY
Heater produces a whistling noise when burner is lit	<ol style="list-style-type: none">1. Turning gas control knob to HI position when burner is cold2. Air in gas line3. Dirty or partially clogged burner orifice	<ol style="list-style-type: none">1. Turn gas control knob to LO position and let warm up for a minute2. Operate burner until air is removed from line. Have gas line checked by local propane/LP or natural gas company3. Clean burner (see <i>Cleaning and Maintenance</i>, page 29) or replace burner orifice
Glass soots	<ol style="list-style-type: none">1. Flame impingement on logs2. Debris around burner air mixer	<ol style="list-style-type: none">1. Adjust the log set so that the flame does not excessively impinge on it2. Inspect the opening at the base of the burner to see that it is NOT packed with any type of material
Fireplace produces a clicking/ticking noise just after burners are lit or shut off	<ol style="list-style-type: none">1. Metal expanding while heating or contracting while cooling	<ol style="list-style-type: none">1. This is normal. If noise is excessive, contact qualified service person
Remote does not function	<ol style="list-style-type: none">1. Battery is not installed or battery power is low	<ol style="list-style-type: none">1. Replace batteries in receiver and hand-held remote control
Fireplace shuts off in use	<ol style="list-style-type: none">1. High or gusting winds2. Low line pressure3. Pilot is partially clogged4. Inner vent pipe leaking exhaust gasses into system5. Glass too loose and air tight gasket leaks in corners after usage6. Bad thermopile or thermo-couple7. Improper vent cap installation	<ol style="list-style-type: none">1. Fireplace has been tested for up to 40 mph winds. However, extreme conditions may occur. See <i>Lighting Instructions</i> on page 262. Contact local propane/LP or natural gas company3. Clean pilot (see <i>Cleaning and Maintenance</i>, page 29)4. Locate and correct all leaks (see <i>Checking Gas Connections</i>, page 21)5. Tighten glass6. Replace faulty component7. Check for proper installation and freedom from debris or blockage

TROUBLESHOOTING

Continued



WARNING: If you smell gas

- Shut off gas supply.
- Do not try to light any appliance.
- Do not touch any electrical switch; do not use any phone in your building.
- Immediately call your gas supplier from a neighbor's phone. Follow the gas supplier's instructions.
- If you cannot reach your gas supplier, call the fire department.

OBSERVED PROBLEM	POSSIBLE CAUSE	REMEDY
Fireplace produces unwanted odors	1. Gas leak. See Warning statement above	1. Locate and correct all leaks (see <i>Checking Gas Connections</i> , page 21)
Gas odor even when control knob is in OFF position	1. Gas leak. See Warning statement above 2. Control valve defective	1. Locate and correct all leaks (see <i>Checking Gas Connections</i> , page 21) 2. Replace control valve
Gas odor during combustion	1. Gas leak. See Warning statement above	1. Locate and correct all leaks (see <i>Checking Gas Connections</i> , page 21)
Dark residue on logs or inside of fireplace	1. Improper log placement 2. Air holes at burner inlet blocked 3. Burner flame holes blocked 4. Improper venting or excessive blockage 5. Excessive amounts of embers and pan material	1. Properly locate logs (see <i>Installing Logs, Lava Rock, and Glowing Embers</i> , page 25) 2. Clean out air holes at burner inlets. Periodically repeat as needed 3. Remove blockage 4. Have the vent system inspected, including the termination cap. Remove any restrictions or obstruction 5. Clear excess embers until a minimum gap of 1/2" remains under the grate

SPECIFICATIONS

CTDV36NR-A

- Rating: 15,400/22,000 Btu/Hr
- Gas Type: Natural
- Ignition: Piezo
- Manifold Pressure: 3.5" W.C.
- Minimum Inlet Supply Pressure: 5.5" W.C.
- Dimensions (Actual size of firebox. Measurements do not include nailing flanges or standoffs): 36" x 41" x 21 1/8"

REPLACEMENT PARTS

Note: Use only original parts. This will protect your warranty coverage for parts replaced under warranty.

PARTS UNDER WARRANTY

Contact authorized retailers of this product. If they can not supply original replacement part(s), call FMI PRODUCTS, LLC's Customer Service Department at 1-866-328-4537.

When calling, have ready:

- your name
- your address
- model and serial numbers of your fireplace
- how fireplace was malfunctioning
- type of gas used (propane/LP or natural gas)
- purchase date

Usually, we will ask you to return the part to the factory.

SERVICE HINTS

When Gas Pressure Is Too Low

- Pilot will not stay lit
- Burners will have delayed ignition
- fireplace will not produce specified heat
- propane/LP gas supply might be low (propane/LP units only)

You may feel your gas pressure is too low. If so, contact your local gas supplier.

TECHNICAL SERVICE

You may have further questions about installation, operation, or trouble shooting. If so, contact FMI PRODUCTS, LLC's Customer Service Department at 1-866-328-4537. When calling please have your model and serial numbers of your heater ready.

You can also visit FMI PRODUCTS, LLC's technical service at www.fmiproducts.com.

ACCESSORIES

Note: Purchase these fireplace accessories from your local retailer. If they cannot supply these accessories, call FMI PRODUCTS, LLC at 1-866-328-4537. for information. You can also write to the address listed on the back of this manual.

NOTICE: All accessories may not be available for all fireplace models.

BRICK LINER KIT

(Not Shown)

BL36D-A - Textured Refractory

BL36DS-A - Standard Refractory

BL36DH-A - Textured Refractory, Herringbone

BL36DHS-A - Standard Refractory, Herringbone

This brick liner adds a touch of style to your direct-vent fireplace. Complete installation and operation instructions included in this manual.

PROPANE/NATURAL GAS CONVERSION KIT

(Not Shown)

Included with **CTDV36NR-A** Model

PCDM-36TA - Propane/LP Gas

NCDM-36TA - Natural Gas

FACE/LOUVER PANEL KIT

(Not Shown)

RLD36 - Rolled Louver, Black

FPD36 - Filligree, Black

FPD36B - Filligree, Brushed Brass

FPD36P - Filligree, Platinum

ROLLED LOUVER TRIM KIT

(Not Shown)

LT36B - Brushed Brass

LT36P - Platinum

DEFLECTION HOOD

(Not Shown)

HD36 - Black (2" Brow)

PERIMETER TRIM KIT

(Not Shown)

PT36 - Black

PT36B - Brushed Brass

PT36P - Platinum

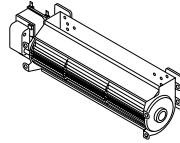

MANUAL BLOWER KIT - BK

Manual variable control blower accessory provides better heat distribution. Complete installation and operation instructions included in this manual.

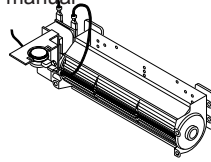

THERMOSTATICALLY- CONTROLLED BLOWER KIT - BKT

Provides better heat distribution. Blower turns off and on automatically, as needed. Complete installation and operation instructions included in this manual.

WALL MOUNTED THERMOSTAT CONTROL KIT - GWMT1

(Not Shown)

Allows easy wall access for thermostatic operation of your fireplace.

WALL MOUNTED ON/OFF SWITCH GWMS2 (Not Shown)

Allows burner system to be turned on and off with a wall switch.

ACCESSORIES

Continued



RECEIVER AND HAND-HELD THERMOSTAT REMOTE CONTROL KIT - CTRC

Allows the fireplace to be turned on and off conveniently without leaving the comfort of your easy chair.



RECEIVER AND HAND-HELD ON/ OFF REMOTE CONTROL KIT - CMRC

Allows the fireplace to be operated in a manually or thermostatically-controlled mode. You can adjust your heat settings and turn the fireplace on or off without leaving the comfort of your easy chair.

ILLUSTRATED PARTS BREAKDOWN

MODEL CTDV36NR-A

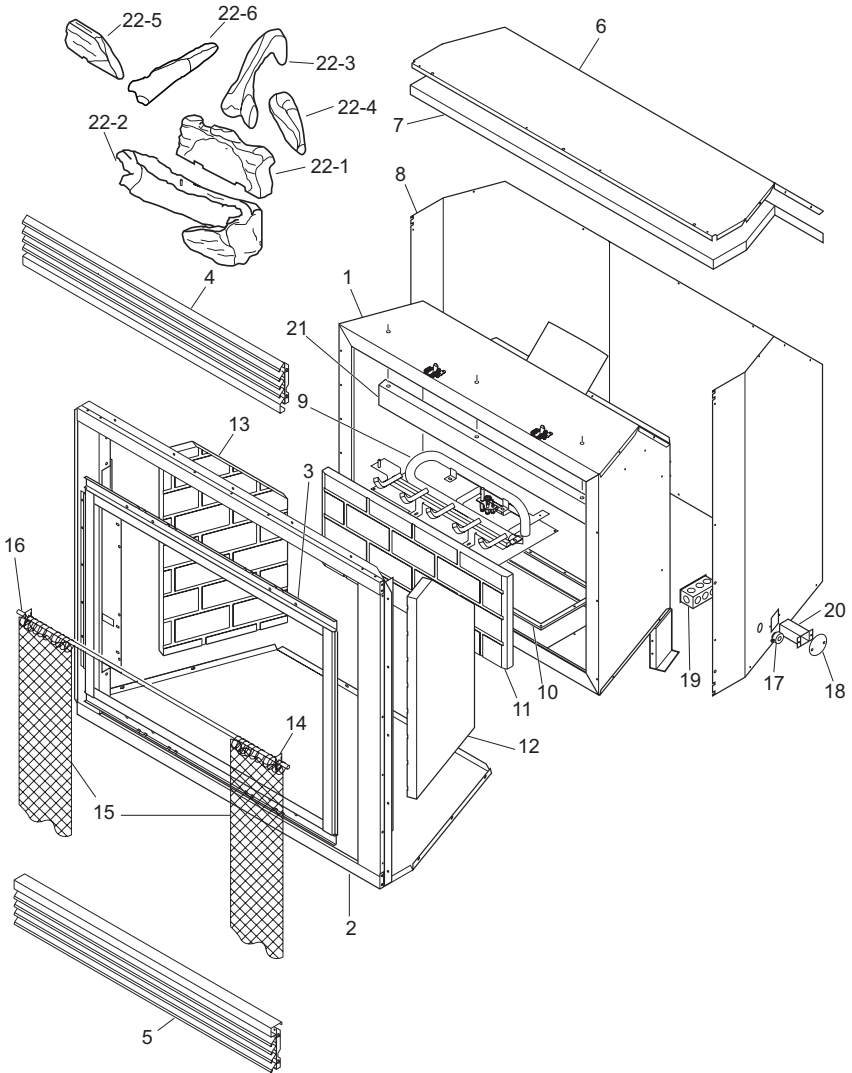

PARTS LIST

MODEL CTDV36NR-A

This list contains replaceable parts used in your fireplace. When ordering parts, follow the instructions listed under *Replacement Parts* on page 35 of this manual.

KEY NO.	PART NO.	DESCRIPTION	QTY.
1	**	Firebox Assembly	1
2	**	Face Weldment	1
3	108010-01	Door Assembly	1
4	108011-01	Top Rolled Louver Assy,	1
5	108011-02	Bottom Rolled Louver Assy,	1
6	108015-01	Fireplace Top	1
7	**	Fireplace Top Insulation	1
8	**	Fireplace Surround	1
9	108074-01	Burner Assembly (Natural) (See pages 40 and 41)	1
10	108076-01	Burner Base Gasket	1
11	see below	Rear Refractory Brick Panel	1
12	see below	Right Refractory Brick Panel	1
13	see below	Left Refractory Brick Panel	1
14	11418	Push-On Nut	2
15	12105	Screen	2
16	108719-01	Screen Rod	1
17	14123	Strain Relief	1
18	21171	Gas Knock-Out Cover	2
19	24353	Handy Box Assembly	1
20	24460	Gas Conduit Assembly	1
21	109082-01	Heat Shield	1
22	109006-01	Log Set	1
22-1	109007-01	Rear Log (Log 1)	1
22-2	110182-01	Front Log (Log 2)	1
22-3	109008-01	Crossover Log (Log 3)	1
22-4	107347-01	Right Top Log (Log 4)	1
22-5	109009-01	Base Log (Log 5)	1
22-6	107348-01	Left Top Log (Log 6)	1
PARTS AVAILABLE - NOT SHOWN			
	25487	Lava Rock/Bag Assy	1
	27253	Notice Label	1
	55240	Vent Label	1
	PCDM-36TA	Conversion Kit	1

** Not a field replaceable part.

CTDV36NR-A	DESCRIPTION	QTY.
110991-01	Rear Refractory Brick Panel	1
110990-01	Right Refractory Brick Panel	1
110989-01	Left Refractory Brick Panel	1

ILLUSTRATED PARTS BREAKDOWN

BURNER FOR MODEL CTDV36NR-A

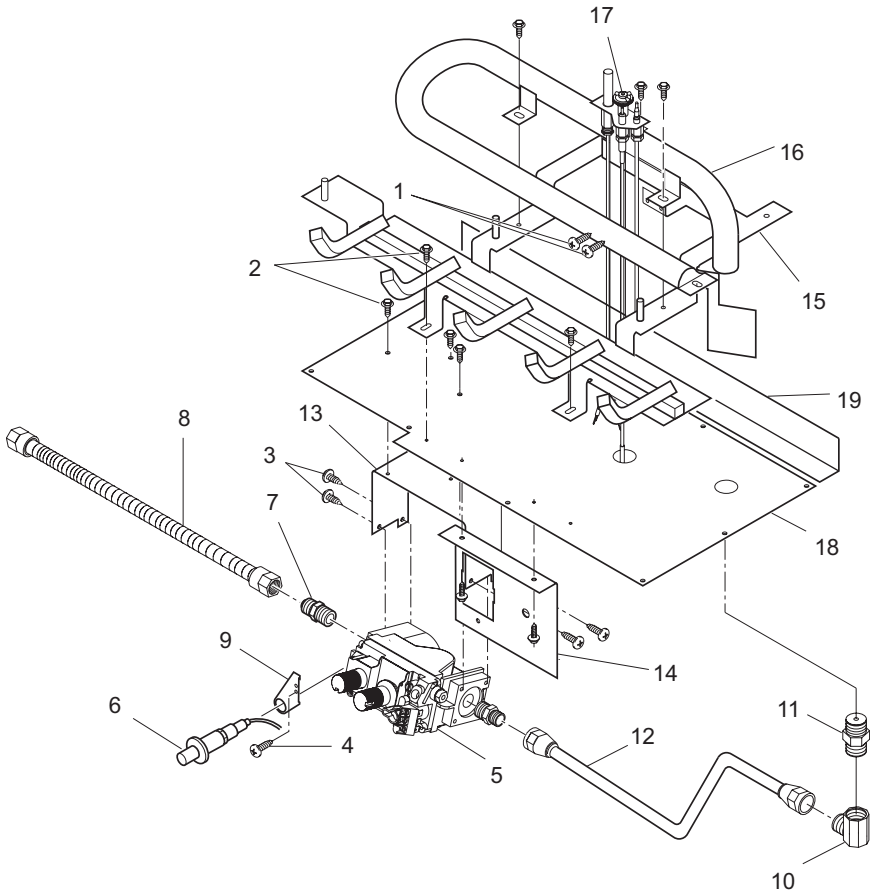

PARTS LIST

BURNER FOR MODEL CTDV36NR-A

This list contains replaceable parts used in your fireplace. When ordering parts, follow the instructions listed under *Replacement Parts* on page 35 of this manual.

KEY NO.	PART NO.	DESCRIPTION	QTY.
1	11102	Screw #8-32 x 3/8 PPH Zinc	2
2	11105	Screw #10 x 1/2 Zinc	9
3	11179	Screw #10-24 x 1/4 Zinc	4
4	11237	Screw, Trilab M4 x 8 mm	1
5	14389	Millivolt Valve (Natural)	1
6	14492	Piezo Ignitor	1
7	14500	Brass Fitting	2
8	14508	Flexible Connector	1
9	14511	Ignitor Bracket	1
10	14528	Brass Elbow Fitting	1
11	14496	Orifice (Natural)	1
12	110984-01	Aluminum Tubing Assembly	1
13	26808	Valve Bracket	1
14	26827	Switch Bracket	1
15	108007-01	Base Grate Assembly	1
16	104504-03	Burner	1
17	108084-02	Pilot Assembly (Natural)	1
18	110996-01	Burner Base Assembly	1
19	110986-01	Air Baffle (Natural)	1

NOTES

WARRANTY

KEEP THIS WARRANTY

Model (located on product or identification tag) _____

Serial No. (located on product or identification tag) _____

Date Purchased _____

Keep receipt for warranty verification.

FMI PRODUCTS, LLC LIMITED WARRANTIES

New Products

Standard Warranty: FMI PRODUCTS, LLC warrants this new product and any parts thereof to be free from defects in material and workmanship for a period of two (2) year from the date of first purchase from an authorized dealer provided the product has been installed, maintained and operated in accordance with FMI PRODUCTS, LLC's warnings and instructions.

For products purchased for commercial, industrial or rental usage, this warranty is limited to 90 days from the date of first purchase.

Factory Reconditioned Products

Limited Warranty: FMI PRODUCTS, LLC warrants factory reconditioned products and any parts thereof to be free from defects in material and workmanship for 30 days from the date of first purchase from an authorized dealer provided the product has been installed, maintained and operated in accordance with FMI PRODUCTS, LLC's warnings and instructions.

Terms Common to All Warranties

The following terms apply to all of the above warranties:

Always specify model number and serial number when contacting the manufacturer. To make a claim under this warranty the bill of sale or other proof of purchase must be presented.

This warranty is extended only to the original retail purchaser when purchased from an authorized dealer, and only when installed by a qualified installer in accordance with all local codes and instructions furnished with this product.

This warranty covers the cost of part(s) required to restore this product to proper operating condition and an allowance for labor when provided by a FMI PRODUCTS, LLC Authorized Service Center or a provider approved by FMI PRODUCTS, LLC. Warranty parts must be obtained through authorized dealers of this product and/or FMI PRODUCTS, LLC who will provide original factory replacement parts. Failure to use original factory replacement parts voids this warranty.

Travel, handling, transportation, diagnostic, material, labor and incidental costs associated with warranty repairs, unless expressly covered by this warranty, are not reimbursable under this warranty and are the responsibility of the owner.

Excluded from this warranty are products or parts that fail or become damaged due to misuse, accidents, improper installation, lack of proper maintenance, tampering, or alteration(s).

This is FMI PRODUCTS, LLC's exclusive warranty, and to the full extent allowed by law; this express warranty excludes any and all other warranties, express or implied, written or verbal and limits the duration of any and all implied warranties, including warranties of merchantability and fitness for a particular purpose to two (2) year on new products and 30 days on factory reconditioned products from the date of first purchase. FMI PRODUCTS, LLC makes no other warranties regarding this product.

FMI PRODUCTS, LLC's liability is limited to the purchase price of the product, and FMI PRODUCTS, LLC shall not be liable for any other damages whatsoever under any circumstances including indirect, incidental, or consequential damages.

Some states do not allow limitations on how long an implied warranty lasts or the exclusion or limitation of incidental or consequential damages, so the above limitation or exclusion may not apply to you.

This warranty gives you specific legal rights, and you may also have other rights which vary from state to state.

For information about this warranty contact:

FMI PRODUCTS, LLC
2701 S. Harbor Blvd.
Santa Ana, CA 92704
1-866-328-4537
www.fmiproductions.com

111250-01
Rev. H
02/11