

42" AND 50" WOOD BURNING MASONRY FIREPLACE OWNER'S OPERATION AND INSTALLATION MANUAL

(V)G42/50

Smooth Face with Insulation

(V)G42R/50R

Smooth Face with Insulation and
Bottom Door Rail

(V)G42H/50H

Smooth Face with Insulation and
Herringbone Refractory

(V)G42HR/50HR

Smooth Face with Insulation, Bottom
Door Rail and Herringbone Refractory



We recommend that our
products be installed and
serviced by professionals who
are certified in the U.S. by NFI
(National Fireplace Institute).
www.nficertified.org

SAVE THIS BOOK

This book is valuable. In addition to instructing you on how to install and maintain your appliance, it also contains information that will enable you to obtain replacement parts or accessory items when needed. Keep it with your other important papers.

This fireplace is approved for use as a wood burning fireplace or for use with a vented gas log approved to ANS Z21.60 or Z21.84 standards or for use with a vent-free gas log heater approved to ANS Z21.11.2 standard.

This wood burning fireplace complies with UL127-CAN/ULS-S610-M87 standard as a **FACTORY BUILT APPLIANCE**.

FOR CANADA: The authority having jurisdiction (such as the municipal building department, fire department, etc.) should be contacted before installation to determine the need to obtain a permit.

INSTALLER: Leave this manual with the appliance.
CONSUMER: Retain this manual for future reference.

TABLE OF CONTENTS

Safety Information	2	Glass Door Installation	12
Specifications	3	Operation and Maintenance Guidelines	13
Fireplace Installation.....	5	Technical Service.....	14
Venting Installation	7	Replacement Parts.....	15
Optional Gas Line Installation.....	11	Accessories	16

SAFETY

⚠ WARNING: Improper installation, adjustment, alteration, service or maintenance can cause injury, property damage or loss of life. Refer to this manual for assistance or additional information. Consult a qualified installer or local distributor.

IMPORTANT: Check local codes before installing this fireplace.

Before beginning the installation of the fireplace, read these instructions through completely.

- This FMI PRODUCTS, LLC fireplace and its components are safe when installed according to this installation manual. Unless you use FMI PRODUCTS, LLC components, which have been designed and tested for the fireplace system, you may cause a fire hazard.
- The FMI PRODUCTS, LLC warranty will be voided by and FMI PRODUCTS, LLC disclaims any responsibility for the following actions.
 - a. Modification of the fireplace, components, doors, air inlet system and damper control.
 - b. Use of any component part not manufactured or approved by FMI PRODUCTS, LLC in combination with a FMI PRODUCTS, LLC fireplace system.

Proper installation is the most important step in ensuring safe and continuous operation of the fireplace. Consult the local building codes as to the particular requirements concerned with the installation of all factory built fireplaces.

⚠ WARNING: Do not install a fireplace insert in this firebox unless the manufacturer's instructions with the insert specifically state this fireplace has been tested for use with the insert.

This fireplace is not intended to be used as a substitute for a furnace to heat an entire home. Use for supplemental heat only.

FOR YOUR SAFETY

- Do not store or use gasoline or any other flammable vapors or liquids in the vicinity of this or any other appliance.
- Due to high temperatures, the appliance should be located out of traffic and away from furniture and draperies.
- Do not place clothing or other flammable materials on or near the appliance.
- Never leave children unattended when a fire is burning in the fireplace.

⚠ WARNING: Use solid wood or processed solid fuel firelogs only. When processed wood fuel fire logs are used, do not poke or stir the logs while they are burning. Use only fire logs that have been evaluated for the application in fireplace and refer to fire log warnings and caution markings on packaging prior to use.

⚠ WARNING: Always leave glass doors fully opened or fully closed when operating fireplace.

SPECIFICATIONS

42" MODELS

ROUND TOP TERMINATION

SQUARE CHASE-TOP TERMINATION

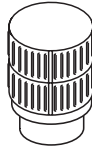

2" CHIMNEY AIRSPACE CLEARANCE TO COMBUSTIBLE MATERIAL

1 1/2" AIR SPACE BACK AND SIDES

OUTSIDE AIR

GAS LINE KNOCKOUTS

0" TO BOTTOM

NO COMBUSTIBLE MATERIAL ON FACE

COMBUSTIBLE WALL BOARD

MINIMUM 18" TO PERPENDICULAR SIDEWALL

HEARTH EXTENSION 66" X 20"

12" EACH SIDE

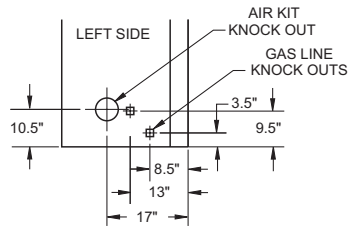
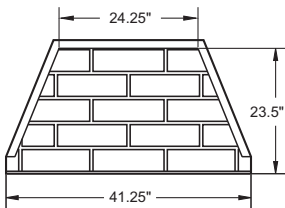
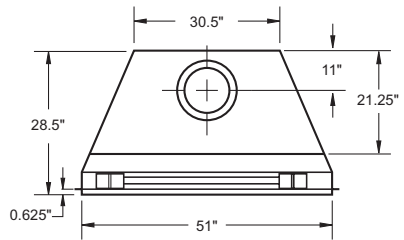
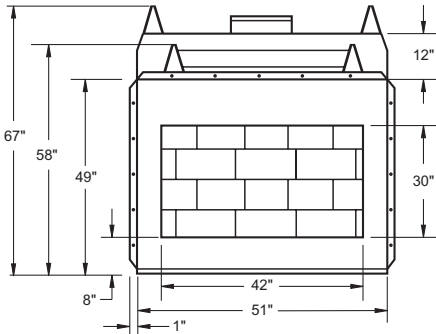

SPECIFICATIONS

50" MODELS

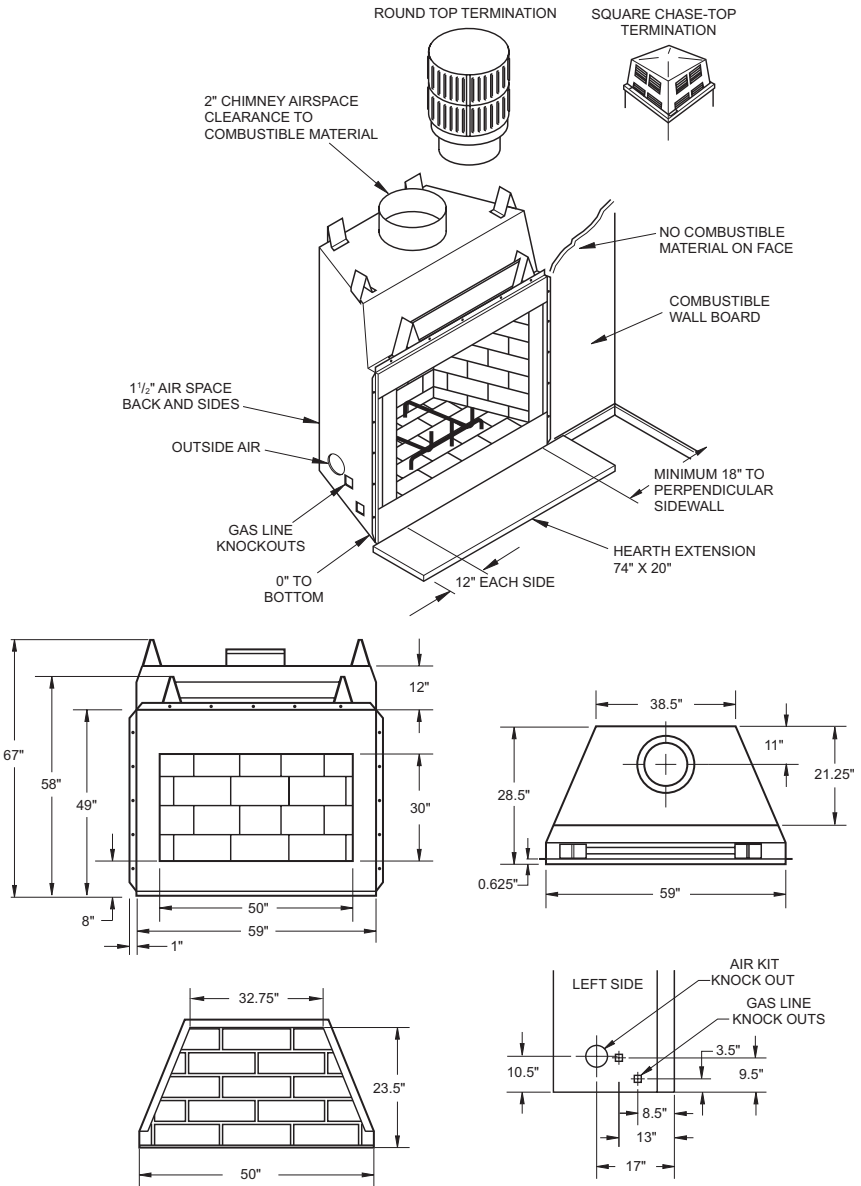

FIREPLACE INSTALLATION

SELECTING LOCATION

To determine the safest and most efficient location for the fireplace, you must take into consideration the following guidelines:

1. The location must allow for proper clearances (see Figures 1 and 2).
2. Consider a location where the fireplace will not be affected by drafts, air conditioning ducts, windows or doors.
3. A location that avoids the cutting of joists or roof rafters will make installation easier.
4. An outside air kit is available with this fireplace (see *Optional Outside Air Kit*, page 6).

MINIMUM CLEARANCE TO COMBUSTIBLES

Back and sides of fireplace	1 1/2" min.*
Front of fireplace	48" min.
Floor**	0" min.
Perpendicular wall to opening	12" min.
Top spacers	0" min.
Mantel clearance	see <i>Mantels</i> , page 5
Chimney outer pipe surface	2" min.

* Not required at nailing flanges

** See step 2 of *Framing*

WARNING: Do not pack required air spaces with insulation or other materials.

Minimum/Maximum Chimney Height

The minimum height of the chimney, measured from the base of the fireplace to the flue gas outlet of the termination, is 16 feet for straight flue or a flue with one elbow set. The maximum distance between elbows is 6 feet. For systems with two elbow sets, the minimum height is 22 feet. The maximum height of any system is 50 feet. This measurement includes the fireplace, chimney sections and the height of the termination assembly at the level of the flue gas outlet (see Figure 15, page 9).

FRAMING

1. Frame opening for fireplace using the dimensions shown in Figures 1 and 2.
2. If fireplace is to be installed directly on carpeting, tile (other than ceramic) or any combustible material other than wood flooring, the fireplace must be installed

- upon a metal or wood panel extending the full width and depth of the fireplace.
3. Set the fireplace directly in front of this opening and slide unit back until nailing flanges touch side framing.
4. Check the level of fireplace and shim with sheet metal if necessary.
5. Before securing fireplace to prepared framing, the ember protector (provided) must be placed between hearth extension (not supplied) and under bottom front edge of fireplace to protect against glowing embers falling through. If the fireplace is to be installed on a raised platform, a Z-type ember protector (not supplied) must be fabricated to fit your required platform height. The ember protector should extend under the fireplace a minimum of 1 1/2". The ember protector should be made of galvanized sheet metal (28 gauge minimum to prevent corrosion).
6. Using screws or nails, secure the fireplace to the framing through flanges located on the sides of the fireplace.

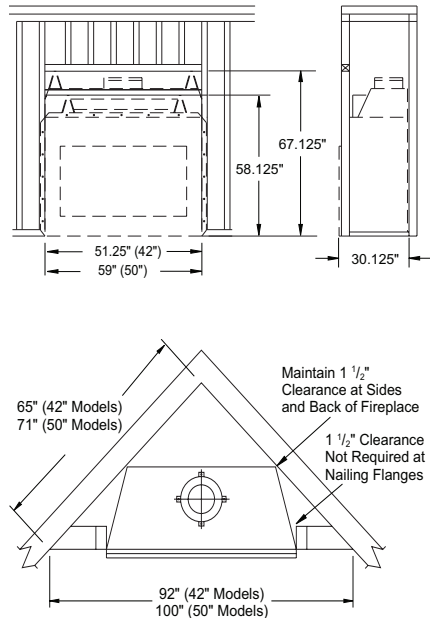

Figure 2 - Corner Installation

VENTING INSTALLATION

OPTIONAL OUTSIDE AIR KIT (MODEL AK4/AK4F)

The installation of an outside air kit should be performed during the rough framing of the fireplace due to the nature of it's location. Outside combustion air is accessed through a vented crawl space (AK4F) or through a sidewall (AK4).

⚠ CAUTION: Combustion air inlet ducts shall not terminate in attic space.

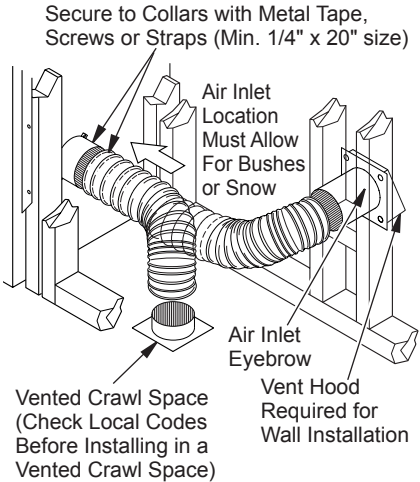

Figure 5 - Outside Air Kit

CHIMNEY PIPE

The FMI PRODUCTS, LLC chimney system consists of 12", 18", 24", 36" and 48" snap-lock, double-wall pipe segments, planned for maximum adaptability to individual site requirements. Actual lengths gained after fitting overlaps must be taken into consideration (lineal gain) and are given in the lineal gain chart (see Figure 6). Lineal Gain is the actual measurable length of a part after two or more parts are connected. For Canada, use chimney parts designated "HT".

⚠ WARNING: The opening in the collar around the chimney at the top of the fireplace must not be obstructed. Never use blown insulation to fill the chimney enclosure.

LINEAL GAIN		
PART NO.	DESCRIPTION	GAIN
Georgian	Fireplace	66 1/2"
12-12DM 12-12HT	Pipe Section	10 5/8"
18-12DM 18-12HT	Pipe Section	16 5/8"
24-12DM 24-12HT	Pipe Section	23 5/8"
36-12DM 36-12HT	Pipe Section	34 5/8"
48-12DM 48-12HT	Pipe Section	46 5/8"
RLT-12D RLT-12HT	Round Termination	7 3/4"*
STL-12D	Square Chase-Top with Slip Section	7" to 15"*

* The lineal gain for the terminations is measured to the flue gas outlet height.

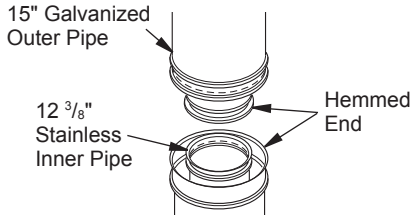

Figure 6 - Lineal Gain

ASSEMBLY AND INSTALLATION OF DOUBLE WALL CHIMNEY SYSTEM

Each double wall chimney section consists of a galvanized outer pipe, a stainless steel inner flue pipe and a wire spacer. Pipe sections must be assembled independently as chimney is installed. When connecting chimney directly to fireplace, the inner flue pipe section must be installed first with lanced side up. The outer pipe section can then be installed over the flue pipe section with hemmed end up. Press down on each pipe section until lances securely engage hem on fireplace starter. The wire will assure the proper spacing between inner and outer pipe sections.

Continue to assemble chimney sections as outlined above, making sure that both inner and outer pipe sections are locked together. When installing double wall snap-lock chimney together, it is important to assure the joint between chimney sections is locked. Check by pulling chimney upward after locking. The chimney will not come apart if properly locked. It is not necessary to add screws to keep the chimney together (exception, see Figure 9, page 9).

VENTING INSTALLATION

Continued

USING ELBOW OFFSETS (30E-12DM)

- To achieve desired offset, you may install combinations of 12", 18", 24", 36" and 48" length of double wall pipe (see offset chart and Figure 7).

OFFSET A	RISE B	CHIMNEY LENGTH				
		12"	18"	24"	36"	48"
4 3/8"	16 3/8"	ELBOW SET ONLY				
9 3/4"	25 1/2"	1				
12 3/4"	30 3/4"		1			
15"	34 3/4"			1		
18"	40"	1	1			
21 1/4"	46 1/4"				1	
23 3/4"	49 1/4"		1	1		
27 3/4"	56 3/4"					1
30"	60 3/4"		1		1	
33"	66"	1				1
36"	71"		1			1
38 1/4"	75"				2	
41 1/4"	80 1/4"	1	1		1	
45"	86 3/4"				2	
46 3/4"	89 1/2"	1	1			1
51"	97"				1	1
53 1/4"	101"		1		2	
56 1/4"	106 1/4"					2
59 1/4"	111 1/2"		1		1	1
61 3/4"	115 1/2"	1				2
64 3/4"	120 3/4"		1			2
68 1/4"	127"				2	1
70"	130"	1	1			2
74 1/4"	137 1/2"	1			2	1
76 3/4"	141 1/2"		1		2	1
79 3/4"	146 3/4"				4	

OFFSET CHART (22-50 FT. SYSTEM HEIGHT)

- Chimney weight above offset rests on return elbow. Straps must be securely nailed to rafters or joists (see Figure 8, details a and b).
- Maximum length of pipe between supports (return elbow or 12S-12DM) is 6' of angle run. Maximum of two 6' angle run sections per chimney system (see Figure 7).
- All pipe connections between the offset and return must be secured with two screws on the outer pipe only (see Figure 9, page 9). Do not penetrate the inner stainless.

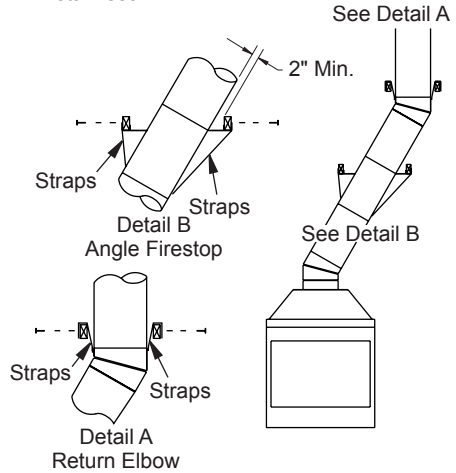

Figure 8 - Ceiling Support Pipe 12S-12DM

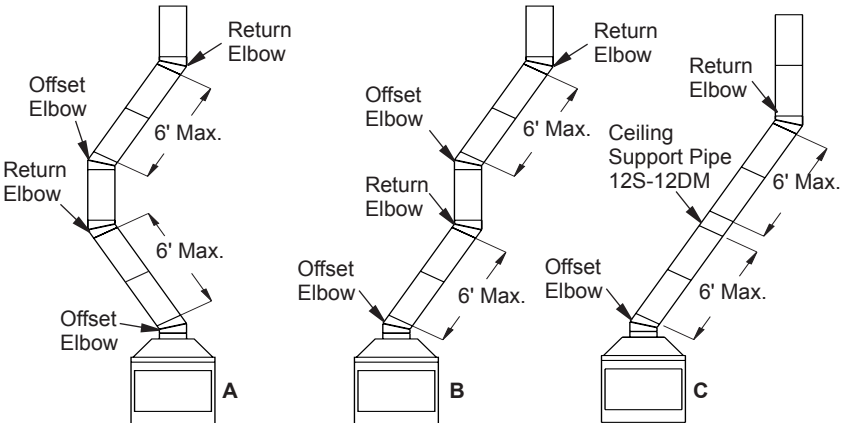

Figure 7 - Typical Offset Terminations

VENTING INSTALLATION

Continued

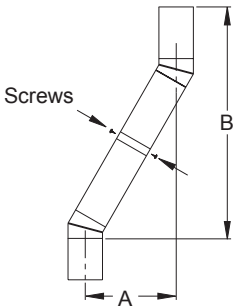

Figure 9 - Elbow Offset

FIRESTOP SPACERS (FS-10)

Firestop spacers are required at each point where the chimney penetrates a floor space. Their purpose is to establish and maintain the required clearance between the chimney and the combustible materials. When the pipe passes through a framed opening into a living space above, the firestop must be placed onto ceiling from below as shown in Figure 10.

They also provide complete separation from one floor space to another or attic space as required by most codes. When the double wall pipe passes through a framed opening into an attic space, the firestop must be placed into an attic floor as shown in Figure 11.

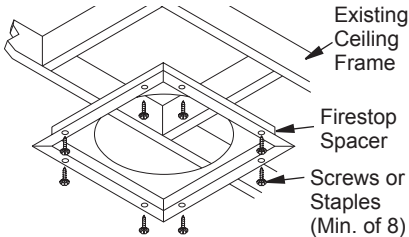

Figure 10 - Firestop Spacer with Living Space Above Ceiling

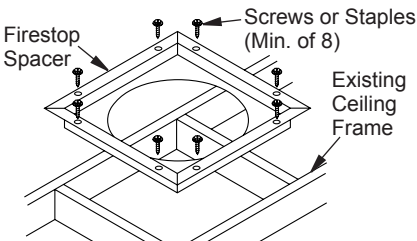
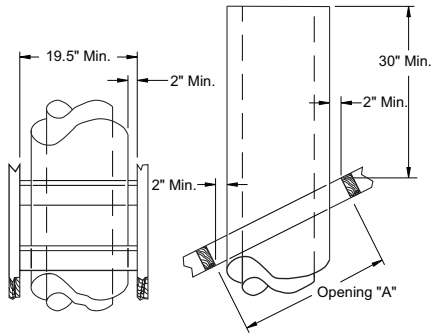

Figure 11 - Firestop Spacer with Attic Space Above Ceiling

PENETRATING ROOF

To maintain a 1" clearance to pipe on a roof with a pitch, a rectangular opening must be cut.

1. Determine the center point through which pipe will penetrate roof.
2. Determine the center point of the roof. Pitch is the distance the roof drops over a given span, usually 12". A 6/12 pitch means that the roof drops 6" for each 12" one measure horizontally down from the roof rafters.
3. Use the roof opening chart (Figure 12) to determine the correct opening length and flashing required.
4. Remove shingles around the opening measured. Cut out this section.
5. Add next sections of pipe until the end penetrates roof line. Check to see that the proper clearances are maintained. Extend chimney by adding sections of double wall pipe until pipe is minimum of 30" above the highest point of the roof cutout. Termination and chimney must extend a minimum of 36" above the highest point where it passes through the roof.



Pitch	Slope	Opening "A" Max.	Used Flashing Model No.
Flat	0°	19.5"	V6F-10DM
0-6/12	26.6°	22"	V6F-10DM
6/12- 12/12	45.0°	27"	V12F-10DM

Figure 12 - Roof Opening Measurements

FLASHING INSTALLATION (V6F-10DM OR V12F-10DM)

Determine flashing to be used with the roof opening chart. Slide flashing over pipe until base is flat against roof. Replace as many shingles as needed to cover exposed area and flashing base. Secure in position by nailing through shingles (see Figure 13, page 10). DO NOT NAIL THROUGH FLASHING CONE.

VENTING INSTALLATION

Continued

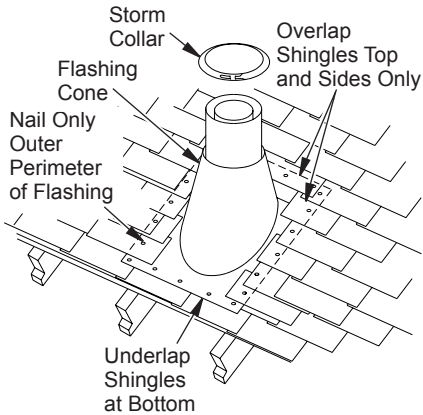

Figure 13 - Flashing Installation

Installing Flashing on a Metal Roof

When installing the flashing on a metal roof, it is required that putty tape be used between the flashing and the roof. The flashing must be secured to the roof using #8 x 3/4" screws and then sealed with roof coating to prevent leakage through the screw holes. A roof coating must also be applied around the perimeter of the flashing to provide a proper seal.

Storm Collar Installation (SC2-1)

Place storm collar over pipe and slide down until it is snug against the open edge of the flashing (see Figure 14). Apply waterproof caulk around the perimeter of the collar to provide a proper seal.

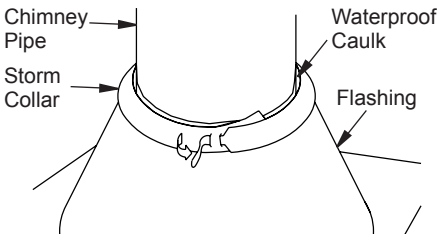

Figure 14 - Storm Collar

Terminations/Spark Arrestor

The fireplace system must be terminated with the listed round top or chase terminations. In any case, refer to the installation instructions supplied with the termination.

CAUTION: Do not seal openings on the rooftop flashing. Follow the installation instructions provided with the termination being used.

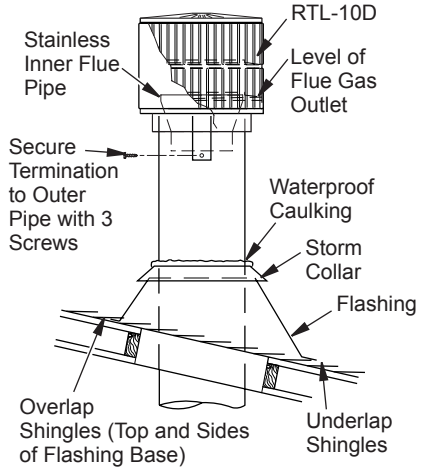

Figure 15 - Termination

CHASE INSTALLATIONS

Instructions for chase installations are included with the chase style termination chosen. In a multiple chase installation, be sure to provide adequate distance between terminations to prevent smoke spillage from one termination to another. Terminations be separated a minimum of 24" center to center and stacked at a minimum vertical height difference of 18" (see Figure 16).

Note: If a decorative shroud is to be installed, contact the manufacturer for specifications.

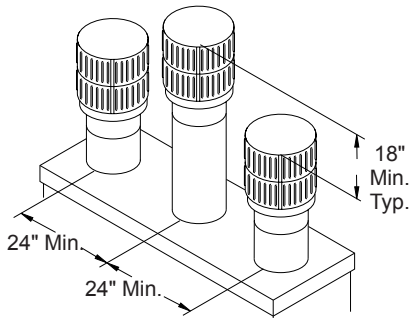

Figure 16 - Multiple Chase Installation

VENTING INSTALLATION

Continued

10 FOOT RULE

All flue gas outlet chimney terminations must extend a minimum of 3 feet in height above the highest point where it passes through the roof and must be at least 2 feet above the highest point of the roof that is within a horizontal distance of 10 feet (see Figure 17).

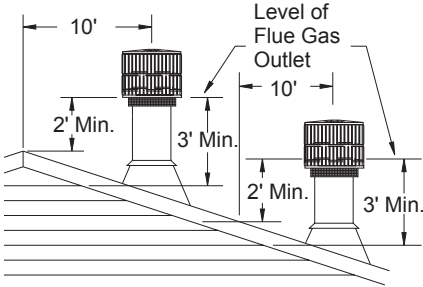

Figure 17 - 10 Foot Rule

FINISHING FIREPLACE

Combustible materials, such as wallboard, gypsum board, sheet rock, drywall, plywood, etc. may make direct contact with sides and top around the fireplace face. It is important that combustible materials do not overlap the face itself. Brick, glass, tile or other noncombustible materials may overlap the front face provided they do not obstruct essential openings like louvered slots or any other opening. When overlapping with a noncombustible facing material, use only noncombustible mortar or adhesive.

OPTIONAL GAS LINE INSTALLATION

Gas line hook up should be done by your supplier or a qualified service person.

Note: Before you proceed, make sure your gas supply is turned off.

Use only a 1/2" black iron pipe and appropriate fittings.

1. Remove knockout indentation on refractory or firebrick wall located above refractory hearth floor. The knockout indentation must be firmly tapped with any solid object such as a 1/2" dowel until it is released. Remove fragmented portions of refractory (see Figure 18).
2. Remove gas line cover plate located on either side of fireplace and pull out insulation from gas line conduit sleeve. Save insulation for reuse. Replace screws.
3. Run a 1/2" black iron gas line into fireplace through the rear at gas line conduit sleeve (if using a raised platform, add height). Provide sufficient gas line into fireplace chamber for fitting connection (see Figure 19). *Note: Secure incoming gas line to wood framing to provide rigidity for threaded end.*
4. Repack insulation around gas line and into sleeve opening. Seal any gaps between gas line and refractory knockout hole with refractory cement or commercial furnace cement. Install the gas appliance or cap off gas line if desired.

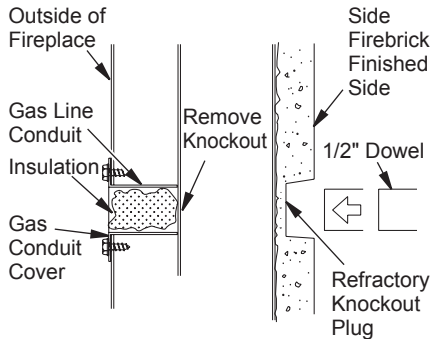

Figure 18 - Gas Line Knockout

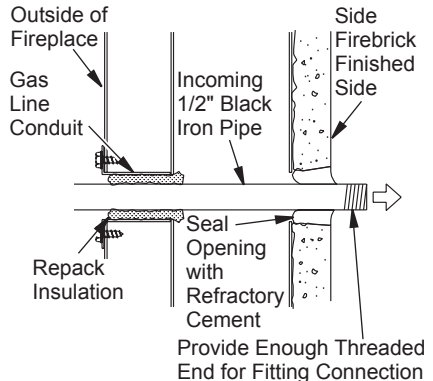

Figure 19 - Gas Line Installation

OPTIONAL GAS LINE INSTALLATION

Continued

⚠ CAUTION: All gas piping and connections must be tested for leaks after the installation is completed. After ensuring that the gas valve is on, apply soap and water solution to all connections and joints. Bubbles forming show a leak. Correct all leaks at once. **DO NOT USE AN OPEN FLAME FOR LEAK TESTING AND DO NOT OPERATE ANY APPLIANCE IF A LEAK IS DETECTED. LEAK TESTING SHOULD BE DONE BY A QUALIFIED SERVICE PERSON.**

⚠ WARNING: Do not operate an unvented gas log set in this fireplace with the chimney removed.

If you install a decorative gas appliance (vented gas log), the decorative gas appliance must comply with the *Standard for Decorative Gas Appliance for Installation in Solid Fuel Burning Fireplaces, ANS Z21.60 or Z21.84* and shall also be installed in accordance with the *National Fuel Gas Code, ANSI Z223NFPA 54 latest edition*.

⚠ WARNING: If the fireplace has been used for wood burning, the firebox and chimney must be cleaned of soot, creosote and ashes by a qualified chimney cleaner. Creosote will ignite if heavily heated.

⚠ WARNING: When using a decorative vented gas log, the damper must be removed or permanently locked in the fully open position and the glass doors must be in the fully open position.

GLASS DOOR INSTALLATION

IMPORTANT: Install glass door frame before installing glass door.

INSTALLING DOOR FRAMES

1. Remove screws from smoke shelf (see Figure 20).
2. Mount top door frame and secure with screws removed in step 1.

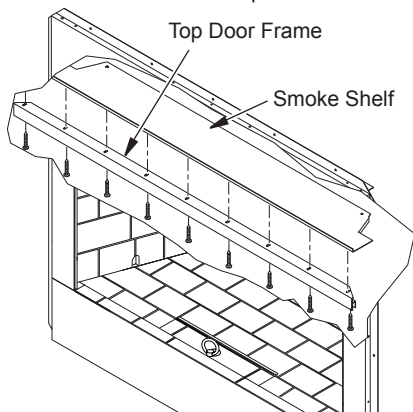

Figure 20 - Installing Top Door Frame

3. Remove center brick by pulling ring handle (see Figure 21).
4. Remove ash box.
5. Remove three screws located at front of firebox (see Figure 21).
6. Align bottom rail mounting holes with holes at front of firebox and secure with screws removed in step 5.
7. Place ash box in place. Replace center brick.

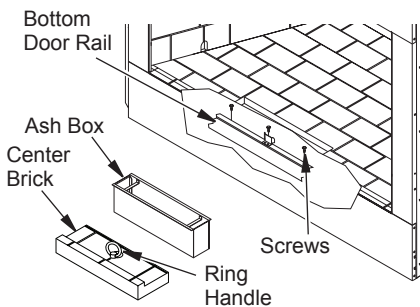

Figure 21 - Installing Bottom Door Frame

GLASS DOOR INSTALLATION

Continued

INSTALLING GLASS DOORS

Spring clips have been installed but some adjustments may be needed. If doors do not close properly or do not appear straight, see [Door Adjustment](#).

1. With bi-fold doors completely folded, insert bottom pivot pin into pivot hole located near bottom corner of front face opening and swing door to vertical position making sure top pins slide into door track.

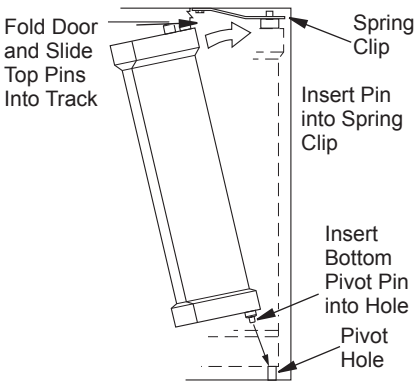

Figure 22 - Installing Bi-Fold Doors

track. Door is installed when top door pin snaps into spring clip.

2. Repeat step 1 for remaining door.

If you find doors do not close properly or do not appear level or straight, proceed with section on door adjustment,

DOOR ADJUSTMENT

Remove doors and slightly loosen lower pivot clips and upper spring clips. Replace doors and fully close them. Use 1/8" shims (any material) to level doors. Once proper setting is achieved, carefully open doors enough so that you can access spring clips with a Phillips screwdriver. Tighten screws. See Figure 23.

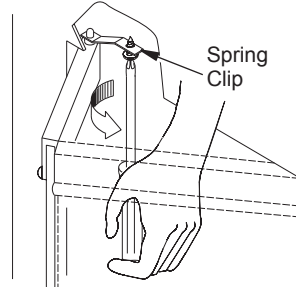

Figure 23 - Adjusting Bi-Fold Doors

OPERATION AND MAINTENANCE GUIDELINES

GLASS DOORS

Glass doors are optional with the fireplace. When fireplace is in operation, doors must be fully opened or fully closed position only or a fire hazard may be created (see Figure 24).

A fireplace equipped with glass doors operates much differently than a fireplace with an open front. A fireplace with glass doors has a limited amount of air for combustion.

Excessive heat within the fireplace can result if too large a fire is built or if combustion air gate is not completely open. The following tips should be followed to assure that both the fireplace and glass door retain their beauty and function properly. Both the flue damper and glass doors must be fully opened before starting fire. This will provide sufficient combustion air and maintain safe temperatures in firebox.

IMPORTANT: The glass must be allowed to warm slowly and evenly. The tempered glass will withstand a gradual temperature rise to

550° F, which is more than a normal fire will generate. Such materials as pitch/wax laden logs, very dry mill end lumber and large amounts of paper or cardboard boxes can create an excessively hot fire and should not be burned in this fireplace. Always keep the fire well back from the doors and never allow flames to contact the glass.

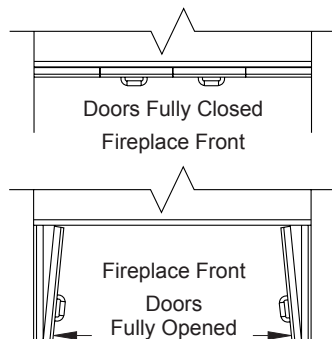

Figure 24 - Bi-Fold Glass Doors

OPERATION AND MAINTENANCE GUIDELINES

Continued

⚠ WARNING: Fireplaces equipped with glass doors should be operated only with doors fully opened or doors fully closed. Doors, if left partly open, may draw gas and flame out of the fireplace opening creating risks of both fire and smoke.

⚠ WARNING: Risk of fire! Replace grate with FMI PRODUCTS, LLC model 109496-01 (42" Models) or 109496-02 (50" Models) grate only. This grate has been designed to keep the operation of your fireplace safe and efficient.

Cleaning Glass

Clean glass with any commercial glass cleaner or soap and water. Do not use any abrasive material to clean glass. Do not clean glass with any cool water if glass is still hot from the fire and smoke.

A gas line or gas log lighter may be installed for the purpose of installing a vented or vent-free decorative gas appliance incorporating an automatic shutoff device and complying with the *Standard for Decorative Gas Appliances for Installation in Vented Fireplaces, ANSI Z21.60* or *American Gas Association draft requirements for Gas Fired Log Lighters for Wood Burning Fireplaces, Draft NO. 4* dated August, 1993.

If you wish to install an unvented (vent-free) gas log set, only unvented gas log sets which have been found to comply with the standard for unvented room heaters, ANSI Z21.11.2 are to be installed in this fireplace.

OUTSIDE AIR AND DAMPER HANDLE OPERATION

The damper handle, which opens and closes the damper blade, is located in the upper front face of the fireplace. Pushing the handle forward and up through the keyway slot will free damper blade to automatically open. Pushing the handle forward and down will lock damper blade closed (see Figure 25).

The outside air kit lever is located at the left and right hand sides of fireplace (see Figure 26). Lifting lever up will free the outside air door to open. Pulling lever down will lock the door.

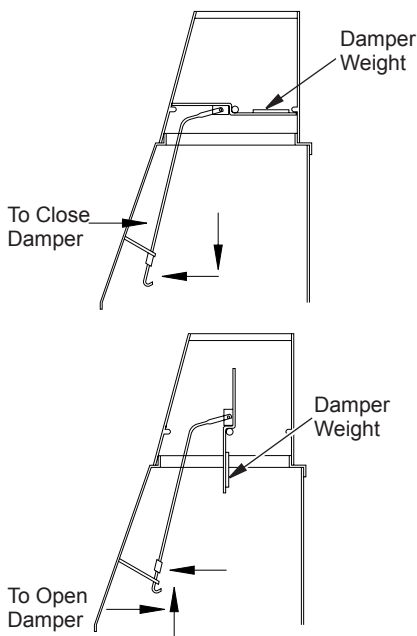

Figure 25 - Operating Damper Handle

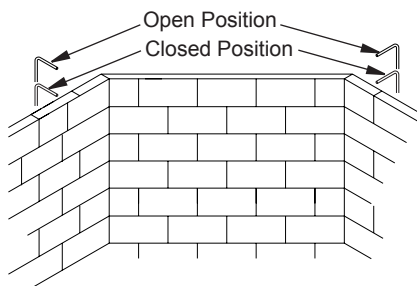

Figure 26 - Outside Air Kit Lever

TECHNICAL SERVICE

You may have further questions about installation, operation, or troubleshooting. If so, contact FMI PRODUCTS, LLC at 1-866-328-4537. When calling please have your model and serial numbers of your heater ready.

You can also visit FMI PRODUCTS, LLC's web site at www.fmiproducts.com.

REPLACEMENT PARTS

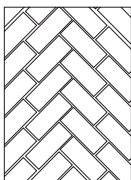

HERRINGBONE BRICK LINER

Bottom Front Brick Refractory

111509-01 - VG42H Models

111509-02 - G42H Models

111515-01SA - VG50H Models

111515-02SA - G50H Models

Bottom Rear Brick Refractory

111510-01 - VG42H Models

111510-02 - G42H Models

111512-01 - VG50H Models

111512-02 - G50H Models

Right Brick Refractory

111507-01 - VG50H Models

111507-02 - G50H Models

111526-01 - VG42H Models

111526-02 - G42H Models

Left Brick Refractory

111508-01 - VG50H Models

111508-02 - G50H Models

111527-01 - VG42H Models

111527-02 - G42H Models

Rear Brick Refractory

111511-01 - VG42H Models

111511-02 - G42H Models

111513-01 - VG50H Models

111513-02 - G50H Models

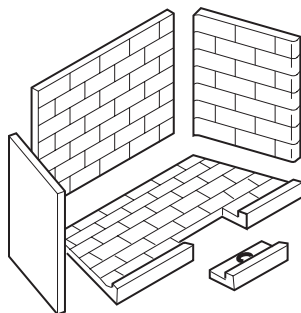

STANDARD BRICK LINER

Bottom Front Brick Refractory

111425-01 - VG42 Models

111425-02 - G42 Models

111430-01 - VG50 Models

111430-02 - G50 Models

Bottom Rear Brick Refractory

111426-01 - VG42 Models

111426-02 - G42 Models

111428-01 - VG50 Models

111428-02 - G50 Models

Right Brick Refractory

111600-01 - VG42 Models

111600-02 - G42 Models

111423-01 - VG50 Models

111423-02 - G50 Models

Left Brick Refractory

111601-01 - VG42 Models

111601-02 - G42 Models

111424-01 - VG50 Models

111424-02 - G50 Models

Rear Brick Refractory

111427-01 - VG42 Models

111427-02 - G42 Models

111429-01 - VG50 Models

111429-02 - G50 Models

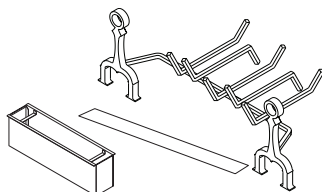

GRATE - (V)G50(H) 109496-01

(V)G42(H) 109496-02

EMBER PROTECTOR - 20093

ASH BOX - 111498-01

109493-01R

www.fmiproducts.com

15

ACCESSORIES

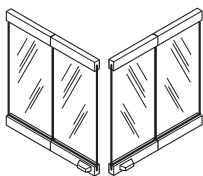

BI-FOLD GLASS DOOR

BDG42 - 42" Black Finish
BDG42B - 42" Brushed Brass Finish
BDG42P - 42" Platinum Finish
BD50 - 50" Black Finish
BD50B - 50" Brushed Brass Finish
BD50P - 50" Platinum Finish

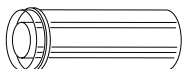

DOUBLE WALL PIPE - 12-12DM,
18-12DM, 24-12DM, 36-12DM, 48-12DM,
12-12HT, 18-12HT, 24-12HT, 36-12HT and
48-12HT

30° OFFSET AND RETURN



30E-12DM and 30E-12HT

OPTIONAL OUTSIDE AIR KIT FOR

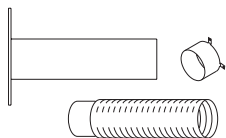

FLOOR INSTALLATION - AK4F

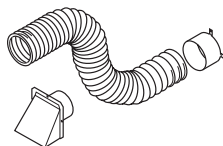

OPTIONAL OUTSIDE AIR KIT FOR SIDEWALL INSTALLATION - AK4

STORM COLLAR - SC2-1



FIRESTOP SPACER FS-10

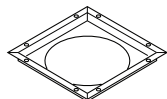

ROOF FLASHING

V6F-10DM - 0 to 6/12 Pitch
V12F-10DM - 6/12 to 12/12
Pitch

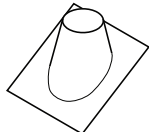

SQUARE CHASE-TOP TERMINATION - STL-12D

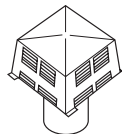

ROUND TOP TERMINATIONS RLT-12D AND RLT-12HT

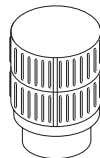

FMI PRODUCTS, LLC
2701 S. Harbor Blvd.
Santa Ana, CA 92704
1-866-328-4537
www.fmiproducts.com

109493-01
Rev. R
09/09