

# PERIMETER TRIM KIT

## GA6094, GAB6094 and GAP6094

### FITS CDCF, CGCF, VDCF, VMH26 SERIES

### COMPACT VENT-FREE GAS FIREPLACES

Includes Hardware Kit 102866-01

## Installation Instructions

### Assembling Perimeter Trim

1. Remove packaging from three remaining pieces of trim.
2. Locate two adjusting plates with set screws, and two shims in the hardware packet.
3. Align shim under adjusting plate as shown in Figure 14.
4. Slide one end of adjusting plate/shim in slot on mitered edge of top trim (see Figure 1).
5. Slide other end of adjusting plate/shim in slot on mitered edge of side trim (see Figure 1).
6. While firmly holding edges of trim together, tighten both set screws on the adjusting plate with slotted screwdriver.
7. Repeat steps 1 through 6 for other corner.

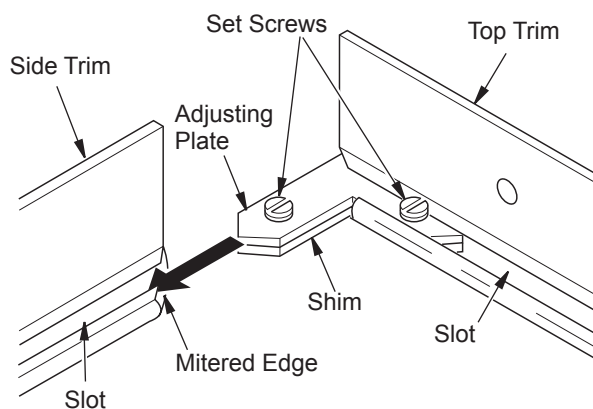

Figure 1 - Assembling Trim

### Installing Perimeter Trim

1. Fireplace should be fully assembled. See *Assembling Fireplace* in fireplace owner's manual.
2. Firmly snap trim assembly on shoulder screws. Shoulder screws are located on fireplace cabinet (see Figure 2).

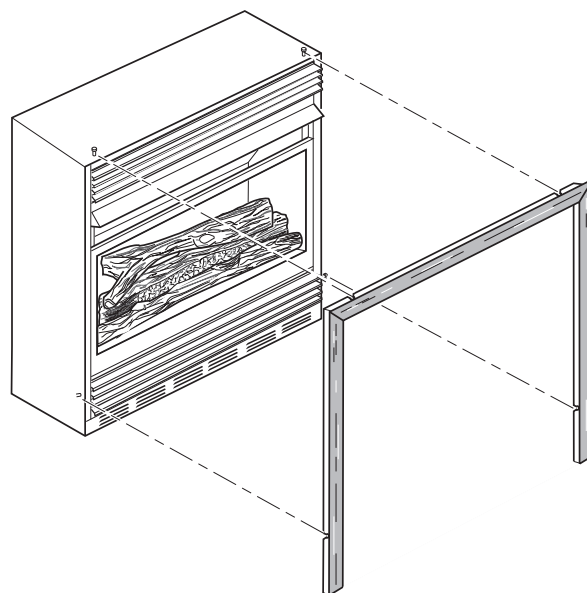

Figure 1 - Attaching Perimeter Trim to Fireplace