

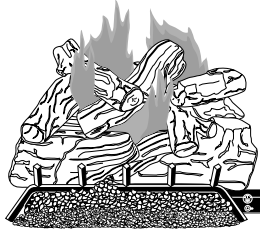


**GAS LOG VENTED DECORATIVE APPLIANCE  
OWNER'S OPERATION AND INSTALLATION MANUAL**

**ANSI Z21.60  
CSA 2.26**

**APPROVED**

Convertible from Natural  
Gas to Propane/LP Gas



**VANGUARD MODELS**

**VVSA18M, VVSA24M, VVDA18M, VVDA24M, VVDA30M**

FOR USE WITH LOG SET MODELS VSLR18, VSLR24, VDLCR18,  
VDLCR24 (SHOWN) AND VDLCR30

**FMI MODELS**

**FVSA18M, FVSA24M, FVDA18M, FVDA24M, FVDA30M**

FOR USE WITH LOG SET MODELS FSLR18, FDLR18, FDLR24 AND FDLR30

These logs are approved by the manufacturer for installation in listed indoor and outdoor solid fuel burning fireplaces. See warranty for additional information.

**⚠ WARNING:** If the information in this manual is not followed exactly, a fire or explosion may result causing property damage, personal injury or loss of life.

- Do not store or use gasoline or other flammable vapors and liquids in the vicinity of this or any other appliance.
- **WHAT TO DO IF YOU SMELL GAS**
  - Do not try to light any appliance.
  - Do not touch any electrical switch; do not use any phone in your building.
  - Immediately call your gas supplier from a neighbor's phone. Follow the gas supplier's instructions.
  - If you cannot reach your gas supplier, call the fire department.
- Installation and service must be performed by a qualified installer, service agency or the gas supplier.

**INSTALLER:** Leave this manual with the appliance.  
**CONSUMER:** Retain this manual for future reference.

## TABLE OF CONTENTS

Safety .....	2	Service Hints .....	12
Product Identification .....	4	Technical Service .....	12
Local Codes .....	4	Troubleshooting .....	13
Product Feature .....	4	Parts .....	16
Unpacking .....	4	Replacement Parts .....	22
Operation .....	10	Accessories .....	22
Inspecting Burners .....	12	Warranty .....	Back Cover
Cleaning and Maintenance .....	12		

## SAFETY

**⚠ WARNING:** Improper installation, adjustment, alteration, service, or maintenance can cause injury or property damage. Refer to this manual for correct installation and operational procedures. For assistance or additional information consult a qualified installer, service agency, or the gas supplier.

**⚠ WARNING:** This appliance is for installation only in a solid-fuel burning masonry or UL127 factory-built fireplace, constructed of noncombustible material, and connected to a working flue. (See page 5 for minimum flue opening.)

**⚠ WARNING:** This is a gas-fired appliance. It uses air (oxygen) from the room in which it is installed. Provisions for adequate combustion and ventilation air must be provided. Refer to the *National Fuel Gas Codes, ANSI Z233.1/NFPA 54, Air for Combustion and Ventilation*.

**⚠ WARNING:** This product contains chemicals known to the State of California to cause cancer or birth defects, or other reproductive harm.

**⚠ WARNING:** Keep flue open when operating unit.

**IMPORTANT:** Read this owner's manual carefully and completely before trying to assemble, operate, or service this log set. Improper use of this log set can cause serious injury or death from burns, fire, explosion, electrical shock, and carbon monoxide poisoning.

**⚠ DANGER:** Carbon monoxide poisoning may lead to death!

**Carbon Monoxide Poisoning:** Early signs of carbon monoxide poisoning resemble the flu, with headaches, dizziness, or nausea. If you have these signs, the log set may not be working properly. **Get fresh air at once!** Have log set serviced. Some people are more affected by carbon monoxide than others. These include pregnant women, people with heart or lung disease or anemia, those under the influence of alcohol, and those at high altitudes.

**Natural and Propane/LP Gas:** Natural and propane/LP gases are odorless. An odor-making agent is added to the gas. The odor helps you detect a gas leak. However, the odor added to the gas can fade. Gas may be present even though no odor exists.

Make certain you read and understand all warnings. Keep this manual for reference. It is your guide to safe and proper operation of this log set.

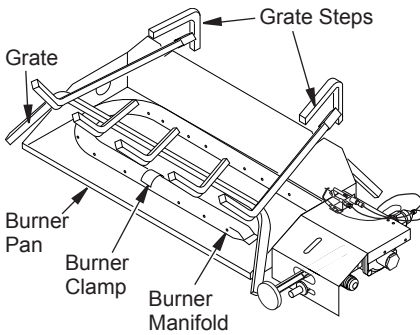
**⚠ WARNING:** Any change to this log set or its controls can be dangerous.

# SAFETY

## Continued

1. This appliance, as supplied, is only for use with the type of gas indicated on the rating plate. This appliance is convertible for use with propane/LP.
2. If you smell gas
  - shut off gas supply
  - do not try to light any appliance
  - do not touch any electrical switch; do not use any phone in your building
  - immediately call your gas supplier from a neighbor's phone. Follow the gas supplier's instructions
  - if you cannot reach your gas supplier, call the fire department
3. Never install the log set
  - in a recreational vehicle
  - where curtains, furniture, clothing, or other flammable objects are less than 42" from the front, top, or sides of the log set
  - in high traffic areas
  - in windy or drafty areas
4. Before installing in a solid fuel burning fireplace, the chimney flue and firebox must be cleaned of soot, creosote, ashes and loose paint by a qualified chimney cleaner. Creosote will ignite if highly heated. Inspect chimney flue for damage.
5. You must operate this log set with fireplace doors or screens in place and fully closed. Unless provided by other means, fireplace doors or screens shall have openings for introduction of combustion air.
6. This log set is designed to be smokeless. If logs ever appear to smoke, turn off appliance and call a qualified service person.  
*Note: During initial operation, slight smoking could occur due to log curing and the burning of manufacturing residues. You may wish to add more ventilation by opening a window.*
7. To reduce the creation of soot, follow the instructions in Cleaning and Maintenance, page 12.
8. Do not allow fans to blow directly into the fireplace. Avoid any drafts that alter burner flame patterns. Ceiling fans can create drafts that alter burner flame patterns. Altered burner patterns can increase sooting.
9. Do not use a blower insert, heat exchanger insert or other accessory not approved for use with this log set.
10. The installation and provisions for combustion and ventilation air must conform with the *National Fuel Gas Codes, ANSI Z233.1/NFPA 54, Air for Combustion and Ventilation*.
11. Do not run log set
  - where combustible materials, gasoline and other flammable vapors and liquids are used or stored
  - under dusty conditions
12. Do not burn solid fuel in the fireplace after installing the log set. Do not use this log set to cook food or burn paper or other objects.
13. Log set becomes very hot when in use. Keep children and adults away from hot surface to avoid burns or clothing ignition. Log set will remain hot for a time after shut-down. Allow surface to cool before touching.
14. Carefully supervise young children when they are in the room with log set.
15. Do not use this appliance if any part has been under water. Immediately call a qualified service technician to inspect the appliance and to replace any part of the control system and any gas control which has been under water.
16. To help prevent breakage, new logs must be broken-in (see Curing Logs, page 11).
17. Turn log set off and let cool before servicing, installing, or repairing. Only a qualified service person should install, service, or repair log set.
18. Provide adequate clearances around air openings.
19. Control knob may be hot when turning unit off. A 6" extension rod is available to make the knob more easily accessible and reduce temperature of control knob (see Accessories on page 22).

## PRODUCT IDENTIFICATION



**Figure 1 - Product Identification (VVDA24 Shown)**

Hearth Kit Model \_\_\_\_\_

Serial Number \_\_\_\_\_

Log Set Model \_\_\_\_\_

## LOCAL CODES

Install and use log set with care. Follow all local codes. In the absence of local codes, use the latest edition of *The National Fuel Gas Code ANSI Z223.1/NFPA 54\**.

\*Available from:

American National Standards Institute, Inc.  
1430 Broadway  
New York, NY 10018

National Fire Protection Association, Inc.  
Batterymarch Park  
Quincy, MA 02269

## PRODUCT FEATURE

### ON/OFF SAFETY VALVE/PILOT

Unit is tested and approved to *ANSI Z21.60* and *CSA 2.26* as a vented decorative appliance. It is supplied with the parts and instructions to convert to propane/LP gas use.

## UNPACKING

**CAUTION:** Do not remove the metal data plates from the burner pan. The data plates contain important warranty and safety information.

1. Remove logs, hearth kit, pan materials, and hardware from carton.
2. Remove all protective packaging applied to logs and base for shipment.
3. Check heater for any shipping damage. If heater is damaged call DESA Heating, LLC at 1-866-672-6040 for replacement parts before returning to dealer.

## INSTALLATION

**WARNING:** The Massachusetts State Board requires all installations be performed by a Licensed Plumber or Gas Fitter. Massachusetts state code requires all vent dampers be welded open or removed.

**CAUTION:** Do not remove the data plates attached to the burner pan. The data plates contain important warranty and safety information.

**WARNING:** Before installing in a solid fuel burning fireplace, the chimney flue and firebox must be cleaned of soot, creosote, ashes and loose paint by a qualified chimney cleaner. Creosote will ignite if highly heated. A dirty chimney flue may create and distribute soot within the house. Inspect chimney flue for damage.

# INSTALLATION

Continued

**NOTICE: Installation, service, and repair of this appliance must be performed by a qualified installer, service agency, company or gas supplier experienced with this type of gas appliance. Only factory authorized components listed in these instructions may be used in accordance with the manufacturer's instructions and all codes and requirements of the authority having jurisdiction. Any modifications to this kit, or use of unauthorized components or accessory items will void the manufacturer's warranty, and may result in a hazardous condition.**

## CHECK GAS TYPE

Use only natural gas. If your gas supply is not natural gas, you must convert the appliance to propane/LP. Follow the instructions on page 8.

If the fireplace does not have a gas supply shutoff valve, one must be installed.

## VENTING SPECIFICATIONS FOR INSTALLATION

The fireplace chimney flue and vent must be drafting properly. To check the vent for proper drafting: Light a tightly rolled newspaper on one end and place it at the inside front edge of the fireplace. Observe the smoke and be sure the vent is properly drawing it up the chimney. If the smoke spills out into the room, extinguish the flame and remove any obstruction until proper venting is achieved.

The chimney flue damper must be fixed open to provide a minimum of 81 sq. in. of free air opening during operation of this log set. A multipurpose damper clamp is provided to fix the damper in position.

The minimum flue sizes shown in Figure 2 are based on a 6' chimney height using round pipe. Your minimum flue size will vary based on input rate and chimney height. Refer to the *National Fuel Gas Code ANSI Z223.1/NFPA 54, Section 6.6*, for details.

## FLUE OPENING SPECIFICATIONS

*Note: This vented appliance must be installed only in a solid-fuel burning fireplace with a working flue and constructed of noncombustible material.*

The charts in Figure 2 indicate technical information regarding the installation of your gas log set. Please make sure that all of the specifications shown are applicable before installation is attempted.

The fireplace must include a working flue and venting system with the minimum openings shown in the Figure 2.

DESCRIPTION	Btu/Hr Input Natural Gas	Btu/Hr Input Propane/LP Gas	Burner Orifice			
			Natural		Propane/LP	
			In.	Num.	In.	Num.
18" Single Burner	50,000	40,000	0.116	32	0.081	46
24" Single Burner	60,000	50,000	0.120	31	0.082	45
18" Dual Burner	55,000	45,000	0.116	32	0.082	45
24" Dual Burner	65,000	55,000	0.138	29	0.086	44
30" Dual Burner	70,000	60,000	0.1405	28	0.089	43

MINIMUM FIREBOX SIZES					
LOG SIZE	FRONT WIDTH	BACK WIDTH*	DEPTH	HEIGHT	MINIMUM FLUE SIZE
18"	34"	16"	14"	18"	8" dia.
24"	35 3/4"	17"	15 1/2"	18"	8" dia.
30"	42"	27"	18"	18"	9" dia.

\* At depth indicated

SPECIFICATIONS (W.C.)			
	FUEL INLET PRESSURE		MANIFOLD PRESSURE
	Min.	Max.	
NG	7" W.C.	10.5" W.C.	6
LP	11" W.C.	14" W.C.	10

Figure 2 - Technical Information Charts

# INSTALLATION

Continued

## INSTALLING DAMPER CLAMP

Secure the damper stop clamp provided to the leading edge of the damper as shown in Figure 3. If for any reason this clamp doesn't work on your fireplace, another suitable clamp or permanent stop must be installed, or the damper blade must be cut or removed.

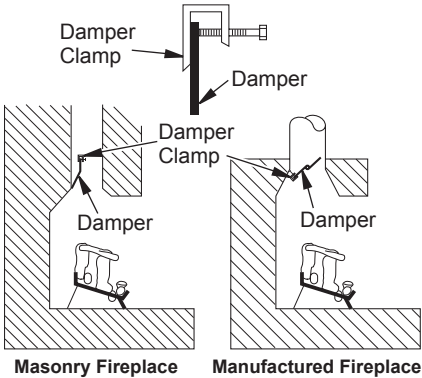


Figure 3 - Attaching Damper Clamp

## CONNECTING TO GAS SUPPLY

**WARNING:** A qualified service person must connect log set to gas supply. Follow all local codes.

### Installation Items Needed

Before installing log set, make sure you have the items listed below.

- piping (check local codes)
- sealant (resistant to propane/LP gas)
- equipment shutoff valve
- adjustable (crescent) wrench or pliers
- sediment trap
- tee joint
- pipe wrench

**CAUTION:** Use only new, black iron or steel pipe. Internally-tinned copper tubing may be used in certain areas. Check your local codes. Use pipe of 1/2" diameter or greater to allow proper gas volume to log set. If pipe is too small, undue loss of volume will occur.

Installation must include an equipment shutoff valve with "T" style handle, gas union and, for propane/LP gas only, a plugged 1/8" NPT tap. Locate NPT tap within reach for test gauge hook up. NPT tap must be upstream from log set (see Figure 4).

**IMPORTANT:** Install equipment shutoff valve in an accessible location. The equipment shutoff valve is for turning on or shutting off the gas to the appliance.

Apply pipe joint sealant lightly to male NPT threads. This will prevent excess sealant from going into pipe. Excess sealant in pipe could result in a clogged burner injector.

**WARNING:** Use pipe joint sealant that is resistant to liquid petroleum (LP) gas.

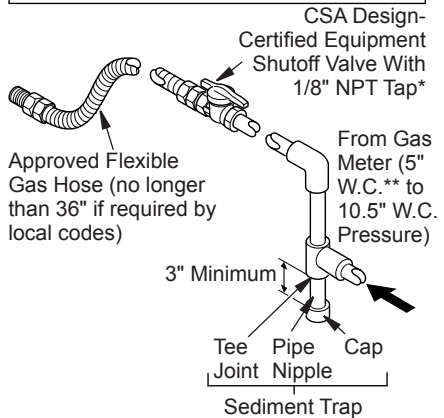


Figure 4 - Gas Connection

\* Purchase the optional CSA design-certified equipment shutoff valve from your dealer.

\*\* Minimum inlet pressure for purpose of input adjustment.

# INSTALLATION

## Continued

We recommend that you install a sediment trap in the supply line as shown in Figure 4, page 6. Locate sediment trap where it is within reach for cleaning. Install in piping system between fuel supply and heater. Locate sediment trap where trapped matter is not likely to freeze. A sediment trap traps moisture and contaminants. This keeps them from going into log set controls. If sediment trap is not installed or is installed wrong, log set may not run properly.

## CHECKING GAS CONNECTIONS

**WARNING:** Test all gas piping and connections, internal and external to unit, for leaks after installing or servicing. Correct all leaks at once.

**WARNING:** Never use an open flame to check for a leak. Apply a noncorrosive leak detection fluid to all joints. Bubbles forming show a leak. Correct all leaks at once.

## PRESSURE TESTING GAS SUPPLY PIPING SYSTEM

### Test Pressures In Excess Of 1/2 PSIG (3.5 kPa)

1. Disconnect log set and its individual equipment shutoff valve from gas supply piping system.
2. Cap off open end of gas pipe where equipment shutoff valve was connected.
3. Pressurize supply piping system by either using compressed air or opening main gas valve located on or near gas meter.
4. Check all joints of gas supply piping system. Apply a noncorrosive leak detection fluid to all joints. Bubbles forming show a leak.
5. Correct all leaks at once.
6. Reconnect log set and equipment shutoff valve to gas supply. Check reconnected fittings for leaks.

### Test Pressures Equal To or Less Than 1/2 PSIG (3.5 kPa)

1. Close equipment shutoff valve (see Figure 5).
2. Pressurize supply piping system by either using compressed air or opening main gas valve located on or near gas meter.

3. Check all joints from gas meter to equipment shutoff valve (see Figure 5). Apply a noncorrosive leak detection fluid to all joints. Bubbles forming show a leak.
4. Correct all leaks at once.

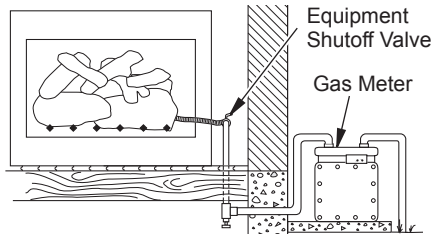


Figure 5 - Checking Gas Joints

## HEARTH PAN INSTALLATION

If using propane/LP gas, see [Propane/LP Gas Conversion](#) on page 8, before installing hearth pan.

1. Place burner pan assembly in center of fireplace floor. Make sure front of pan faces forward.
2. Thread gas supply fitting to fireplace gas supply pipe. Adjust to most convenient position.
3. Install gas connector tube to gas supply adapter. Carefully shape tube and attach to gas inlet fitting (see Figure 6). Be careful not to cause kinks in tube.
4. Test for leaks following instructions under [Testing Burner for Leaks](#), page 9.
5. Retighten and adjust location of gas control as necessary. Gas control should be level, with control rod to the front.

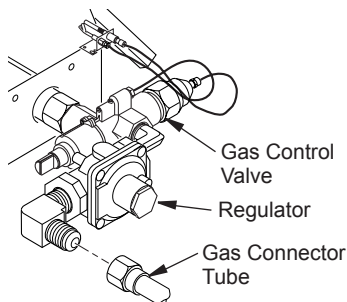


Figure 6 - Installing Inlet Fitting and Gas Connector Tube (Valve Cover Removed for Clarity)

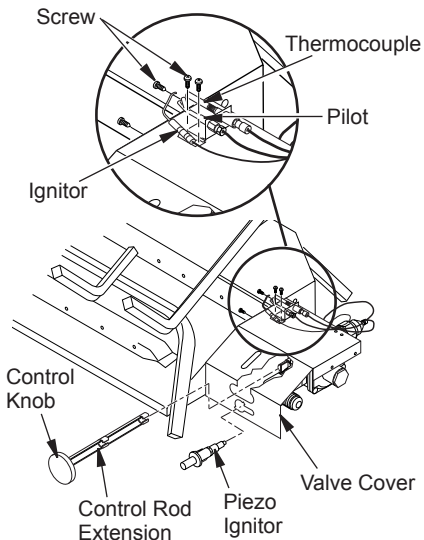
# INSTALLATION

*Continued*

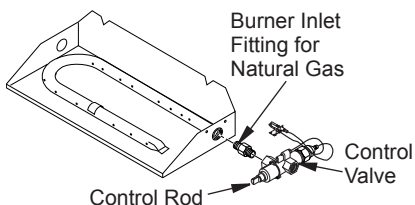
## Propane/LP Gas Conversion

To convert to propane/LP gas, burner inlet fitting and pilot orifice must be replaced and regulator pressure must be reset. Propane/LP burner inlet fitting is supplied with orifice installed. Propane/LP pilot orifice for converting pilot is supplied and is marked with a red stripe.

1. Remove control rod extension and piezo ignitor by pulling gently.
2. Remove screws that attach pilot assembly to valve cover and valve cover to burner pan (see Figure 7).
3. Remove valve cover.
4. Using a wrench, remove gas control valve and burner inlet fitting by turning counter-clockwise (see Figure 8).

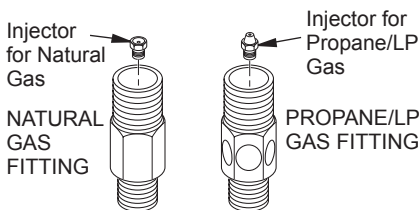


**Figure 7 - Removing/Installing Cover, Control Knob, and Piezo Ignitor**

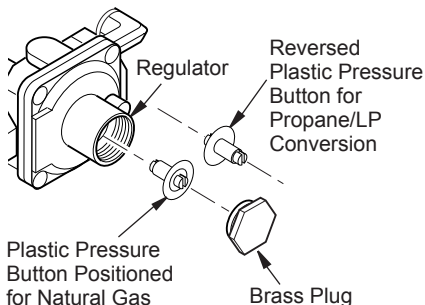


**Figure 8 - Remove Burner Inlet Fitting**

5. Remove burner inlet fitting from gas control assembly (see Figure 8). DO NOT remove orifice from this fitting. Propane/LP burner inlet fitting is included in hardware kit (see Figure 9).
6. Be sure to use correct orifice for your appliance. Orifice kit included with this appliance contains an orifice installed in an air mixer fitting.
7. Using thread sealant (resistant to the action of propane/LP gas) on smaller end of fitting, screw burner inlet fitting into outlet side of gas control (see Figure 8). Tighten using a wrench.
8. Thread gas control valve and burner inlet fitting into burner manifold (see Figure 8). Use thread sealant on male threads of burner inlet fitting. Secure with a wrench. Make sure control rod is facing the front (see Figure 8).
9. To adjust regulator pressure, remove the brass hex plug from regulator (see Figure 10).
10. Remove the plastic pressure button from the brass plug (see Figure 10).
11. Reverse the plastic pressure button and replace it into the brass plug (see Figure 10).



**Figure 9 - Burner Inlet Fittings with Injectors**



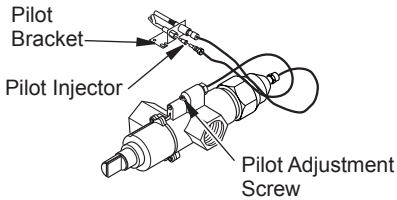
**Figure 10 - Adjusting Regulator Pressure for Conversion**



# INSTALLATION

## Continued

12. Replace brass plug into regulator.
13. Using two screws removed in step 2, page 8, replace valve cover.
14. Gently loosen and remove the pilot line connection from the pilot bracket (see Figure 11).
15. Replace injector with propane/LP injector with red stripe.
16. Replace and tighten pilot line to bracket.
17. Using screws removed in step 2, page 8, reattach pilot bracket to valve cover.
18. Continue with step 1 under *Hearth Pan Installation*, page 7.



**Figure 11 - Installing Propane/LP Pilot Orifice**

## TESTING BURNER FOR LEAKS

1. Generously apply soapy solution to all connections.

**WARNING: Never check for gas leaks with open flame.**

2. Light the burner with the shutoff valve no more than half open and holding a match slightly in front of the pan (see *Lighting Instructions*, page 11).
3. Inspect all connections for bubbles, raw gas odor, or flame from any area other than the burner (leaks). If leaks are detected, shut off the gas valve immediately. Tighten, or reassemble the loose connection(s) using pipe joint compound until burner system is leak free.
4. When the burner is tested and leak free, observe the individual tongues of flame on the burner.

*Note: The burner design includes more ports on the outside of the bar. Make sure that all ports are clear and producing flame evenly across the burner. If any ports appear blocked, clear them by removing the burner manifold and reaming the ports with a modified paper clip or other suitable tool.*

5. When finished testing, turn the gas shutoff valve OFF to extinguish all flames.

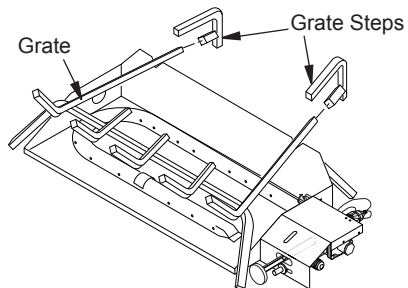
## ADDING PAN MATERIAL

1. Open the bag of ash bed material (vermiculite) and spread it evenly across the burner pan to the top. You may overflow the front and sides of the pan to cover the entire pan. Do not cover valve or inlet fitting.
2. Open the glowing embers and evenly cover the ash bed material (vermiculite) in the burner pan.

## INSTALLING THE GRATE AND LOGS

1. Place the grate over the burner pan where the two outer horizontal supports on the grate fit into the two pan positioning notches in the rear vertical edge of the pan.
2. Slide the two rear log grate steps over the two outer horizontal supports on the grate as shown in Figure 12.
3. Place the back log on the grate onto the grate steps (see Figure 13, page 10).
4. Place the front log(s) on the grate and slide forward against the front bars on the grate (see Figure 13, page 10).
5. Place the smaller top logs onto the bottom logs (see Figure 14, page 10). Leave as much open space between logs as possible to minimize flame impingement and sooting.

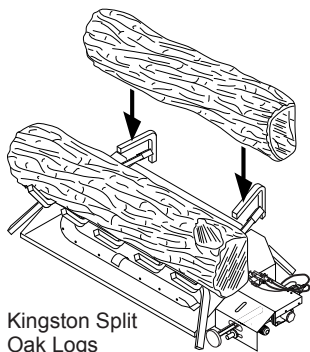
*Note: Logs may chip if they are handled roughly or if hit together while being placed.*



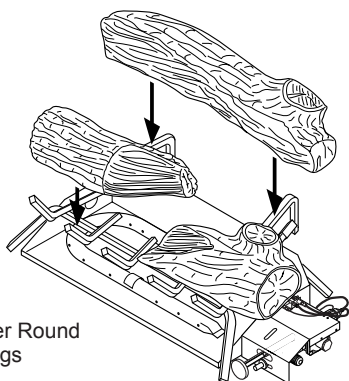
**Figure 12 - Installing Grate (Pan Material Not Shown)**

## INSTALLATION

Continued

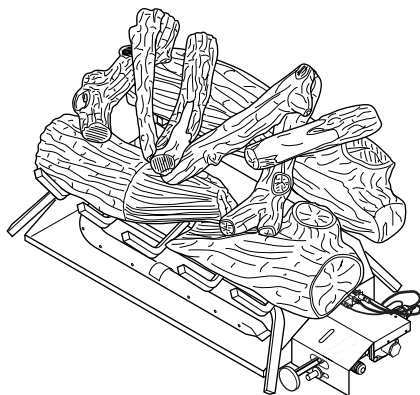


Kingston Split  
Oak Logs



Hanover Round  
Oak Logs

*Figure 13 - Installing Front and Back  
Logs (Number and style of your logs  
may vary)*



*Figure 14 - Placement of Top Logs  
(Kingston Split Oak Logs Shown)*

## OPERATION

**FOR YOUR SAFETY  
READ BEFORE LIGHTING**

**WARNING:** Keep flue open  
when operating unit.

**WARNING:** If you do not fol-  
low these instructions exactly,  
a fire or explosion may result  
causing property damage, per-  
sonal injury or loss of life.

A. This appliance has a pilot which must be lighted by hand. When lighting the pilot, follow these instructions exactly.

B. **BEFORE LIGHTING** smell all around the appliance area for gas. Be sure to smell next to the floor because some gas is heavier than air and will settle on the floor.

### WHAT TO DO IF YOU SMELL GAS

- Do not try to light any appliance.
- Do not touch any electric switch; do not use any phone in your building.
- Immediately call your gas supplier from a neighbor's phone. Follow the gas supplier's instructions.
- If you cannot reach your gas supplier, call the fire department.

# OPERATION

Continued

- C. Use only your hand to push in or turn the gas control knob. Never use tools. If the knob will not push in or turn by hand, don't try to repair it, call a qualified service technician or gas supplier. Force or attempted repair may result in a fire or explosion.
- D. Do not use this appliance if any part has been under water. Immediately call a qualified service technician to inspect the appliance and to replace any part of the control system and any gas control which has been under water.

## LIGHTING INSTRUCTIONS

1. STOP! Read the safety information on page 10.
2. Make sure equipment shutoff valve is fully open.
3. Press in and turn control knob clockwise ↻ to the OFF position.
4. Wait five (5) minutes to clear out any gas. Then smell for gas, including near the floor. If you smell gas, STOP! Follow "B" in the safety information, page 10. If you don't smell gas, go to the next step.
5. Turn control knob counterclockwise ↺ to the PILOT position and press in. Keep control knob pressed in for five (5) seconds.

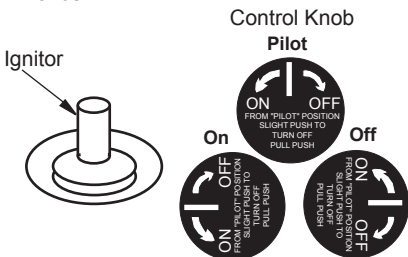


Figure 15 - Ignitor and Control Knob

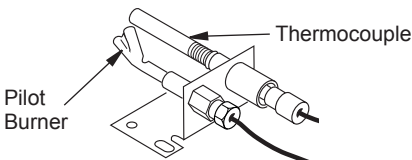


Figure 16 - Thermocouple and Pilot

Note: You may be running this log set for the first time after hooking up to gas supply. If so, the control knob may need to be pressed in for 30 seconds or more. This will allow air to bleed from the gas system.

- If control knob does not pop up when released, contact a qualified service person or gas supplier for repairs.
6. With control knob pressed in, push down and release ignitor button. This will light pilot. Visually locate the pilot on the control valve cover by the edge of the burner pan to look for flame. If needed, keep pressing ignitor button until pilot lights.

Note: If the pilot will not stay lit after several tries, turn the gas control knob to OFF and call your service technician or gas supplier.

7. Keep control knob pressed in for 30 seconds after lighting pilot. After 30 seconds, release control knob.
- Note: If pilot goes out, repeat steps 3 through 7.
8. Turn control knob counterclockwise ↺ to the ON position. Burner should light. If burner does not light, call a qualified service person.
9. To leave pilot lit and shut off burners only, turn control knob clockwise ↻ to the PILOT position.

## TO TURN OFF GAS TO APPLIANCE

1. Turn control knob clockwise ↻ to the PILOT position.
2. Press in and turn control clockwise ↻ to the OFF position.
3. Close equipment shutoff valve (see Figure 5, page 7).

## CURING LOGS

During 2-3 hour appliance break-in period, you may detect an odor from the appliance as various paints and compounds used in manufacturing of this log set cure. This is a normal and temporary situation that is not cause for alarm. However, you may want to provide extra ventilation to the room during this time.

To ensure proper curing of logs:

- Ignite a 2" flame and maintain it for 1 hour.
- Burn logs in consecutive 1 hour periods raising flame an additional 2" to full flame height for a total of three hours.

## INSPECTING BURNERS

Check pilot flame pattern and burner flame patterns often.

### PILOT ASSEMBLY

The pilot assembly is factory preset for proper flame height. Alterations may have occurred during shipping and handling. The pilot is located on the back right hand side of the burner.

The thermocouple should be fully enveloped in flame. The flame should not be lifting off of thermocouple element.

If your pilot assembly does not meet these requirements:

- Access pilot adjustment screw through slot in valve cover. Turn adjustment screw clockwise to decrease or counterclockwise to increase the flame to proper size (see Figure 11, page 9). Do not remove adjustment screw.
- see *Troubleshooting*, page 13

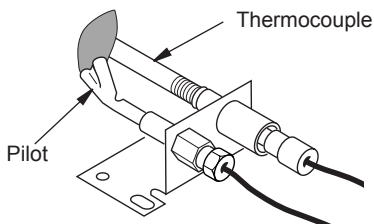


Figure 17 - Correct Pilot Flame Pattern

### BURNER FLAME PATTERN

Burner flames will be steady, not lifting or floating. Flames should go up through middle of logset. Flames should not "spill" to edges of pan or sides of logset.

Figure 18 shows a typical flame pattern. If burner flame pattern differs from that described:

- turn appliance off (see *To Turn Off Gas to Appliance*, page 11)
- see *Troubleshooting*, page 13

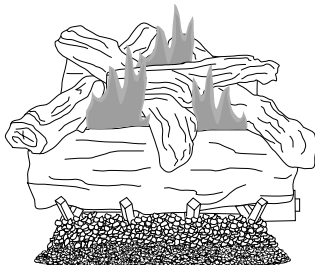


Figure 18 - Typical Flame Pattern

## CLEANING AND MAINTENANCE

- Keep the area around the log set clean and clear of debris.
- Occasionally, you may use a soft bristle brush to clean logs.
- Periodically inspect the air mixer and burner tube for foreign matter blocking the air inlet and flame holes.
- Once every year a qualified agency or certified chimney sweep should examine and clean the venting system of the fireplace.

## SERVICE HINTS

### When Gas Pressure is Too Low

- pilot will not stay lit
- burners will have delayed ignition
- heater will not produce specified heat
- propane/LP gas supply may be low

You may feel your gas pressure is too low. If so, contact your local natural gas supplier.

## TECHNICAL SERVICE

You may have further questions about installation, operation, or troubleshooting. If so, contact DESA Heating, LLC at 1-866-672-6040. When calling please have your model and serial numbers of your heater ready.

You can also visit DESA Heating, LLC's web site at [www.desatech.com](http://www.desatech.com).

## TROUBLESHOOTING



**WARNING: Turn off log set and let cool before servicing. Only a qualified service person should service and repair log set.**

*Note: All troubleshooting items are listed in order of operation.*

OBSERVED PROBLEM	POSSIBLE CAUSE	REMEDY
Log set is smoking/sooting excessively. <i>(Note: It is natural and unavoidable for vented gas log sets to produce moderate levels of carbon (soot) where flames contact the logs. This is especially true with propane/LP gas.)</i>	<ol style="list-style-type: none"> <li>1. Poor fuel quality.</li> <li>2. Fireplace venting system not drafting properly.</li> <li>3. Excessive flame impingement or blockage.</li> <li>4. Improper fuel/air mixture.</li> <li>5. Excessive gas supply/presure.</li> </ol>	<ol style="list-style-type: none"> <li>1. Contact local natural or propane/LP gas company.</li> <li>2. Adjust damper wide open and/or have fireplace and venting professionally cleaned and checked.</li> <li>3. Separate the logs to allow more flame passage.</li> <li>4. Remove any foreign items from the flame pattern and/or check for proper orifice sizing.</li> <li>5. Preheat flue in very cold weather.</li> </ol>
Burner is excessively noisy. <i>(Note: The movement and combustion of gas will create low, unavoidable levels of noise.)</i>	<ol style="list-style-type: none"> <li>1. Passage of air/gas across irregular surfaces.</li> <li>2. Excessive gas pressure on natural gas units.</li> </ol>	<ol style="list-style-type: none"> <li>1. Relieve any tight bends or kinks in gas supply line.</li> <li>2. Check/reset gas regulator pressure (see Figure 10, page 8).</li> </ol>
Burner flame is too low or too high.	<ol style="list-style-type: none"> <li>1. Incorrect gas supply or pressure.</li> <li>2. Blocked burner orifice or burner manifold ports.</li> <li>3. Improper burner orifice size.</li> </ol>	<ol style="list-style-type: none"> <li>1. Check for proper gas supply pressure.</li> <li>2. Free burner orifice and manifold ports of any burrs, paint, or other blockage.</li> <li>3. Verify proper burner orifice sizing (see Figure 2, page 5).</li> </ol>
When ignitor button is pressed, there is no spark at pilot.	<ol style="list-style-type: none"> <li>1. Ignitor electrode not connected to ignitor cable.</li> <li>2. Ignitor cable pinched or wet.</li> <li>3. Bad ground on piezo ignitor.</li> <li>4. Broken ignitor cable.</li> <li>5. Bad piezo ignitor.</li> <li>6. Ignitor electrode broken.</li> <li>7. Ignitor electrode positioned wrong.</li> </ol>	<ol style="list-style-type: none"> <li>1. Reconnect ignitor cable.</li> <li>2. Free ignitor cable if pinched by any metal or tubing. Keep ignitor cable dry.</li> <li>3. Scrape away paint on bracket for better contact with ground on piezo ignitor.</li> <li>4. Replace ignitor cable.</li> <li>5. Replace piezo ignitor.</li> <li>6. Replace electrode.</li> <li>7. Reposition electrode.</li> </ol>

# TROUBLESHOOTING

*Continued*

OBSERVED PROBLEM	POSSIBLE CAUSE	REMEDY
When ignitor button is pressed, there is spark at pilot but no ignition.	<ol style="list-style-type: none"> <li>1. Gas supply turned off or equipment shutoff valve closed.</li> <li>2. Control knob not in PILOT position.</li> <li>3. Control knob not pressed in while in PILOT position.</li> <li>4. Air in gas lines when installed.</li> <li>5. Pilot adjustment screw closed.</li> <li>6. Pilot is clogged.</li> <li>7. Low gas pressure.</li> </ol>	<ol style="list-style-type: none"> <li>1. Turn on gas supply or open equipment shutoff valve.</li> <li>2. Turn control knob to PILOT position.</li> <li>3. Press in control knob while in PILOT position.</li> <li>4. Continue holding down control knob. Repeat igniting operation until air is removed.</li> <li>5. Adjust pilot flame for approximately 2" blue flame.</li> <li>6. Clean pilot (see <i>Cleaning and Maintenance</i>, page 12) or replace pilot assembly.</li> <li>7. Replace gas control.</li> </ol>
Pilot lights but flame goes out when control knob is released.	<ol style="list-style-type: none"> <li>1. Control knob not fully pressed in.</li> <li>2. Control knob not pressed in long enough.</li> <li>3. Equipment shutoff valve not fully open.</li> <li>4. Pilot flame not touching thermocouple, which allows thermocouple to cool, causing pilot flame to go out. This problem could be caused by one or both of the following: A) Low gas pressure B) Dirty or partially clogged pilot</li> <li>5. Thermocouple connection loose at control valve.</li> <li>6. Thermocouple damaged.</li> <li>7. Control valve damaged.</li> </ol>	<ol style="list-style-type: none"> <li>1. Press in control knob fully.</li> <li>2. After pilot lights, keep control knob pressed in 30 seconds.</li> <li>3. Fully open equipment shutoff valve.</li> <li>4. A) Contact local natural gas company.  B) Clean pilot (see <i>Cleaning and Maintenance</i>, page 12) or replace pilot assembly.</li> <li>5. Hand tighten until snug, then tighten 1/4 turn more.</li> <li>6. Replace thermocouple.</li> <li>7. Replace control valve.</li> </ol>
Burner does not light after pilot is lit.	<ol style="list-style-type: none"> <li>1. Burner orifice clogged.</li> <li>2. Inlet gas pressure is too low.</li> <li>3. Burner orifice diameter is too small.</li> <li>4. Thermocouple leads disconnected or improperly connected.</li> </ol>	<ol style="list-style-type: none"> <li>1. Clean burner orifice.</li> <li>2. Contact local natural or propane/LP gas company.</li> <li>3. Replace burner orifice.</li> <li>4. Reconnect leads.</li> </ol>
Delayed ignition burner.	<ol style="list-style-type: none"> <li>1. Pilot flame needs adjusting.</li> <li>2. Wrong pilot orifice.</li> </ol>	<ol style="list-style-type: none"> <li>1. Adjust pilot flame for approximately 2" blue flame.</li> <li>2. Replace pilot orifice set.</li> </ol>

# TROUBLESHOOTING

*Continued*



**WARNING:** If you smell gas

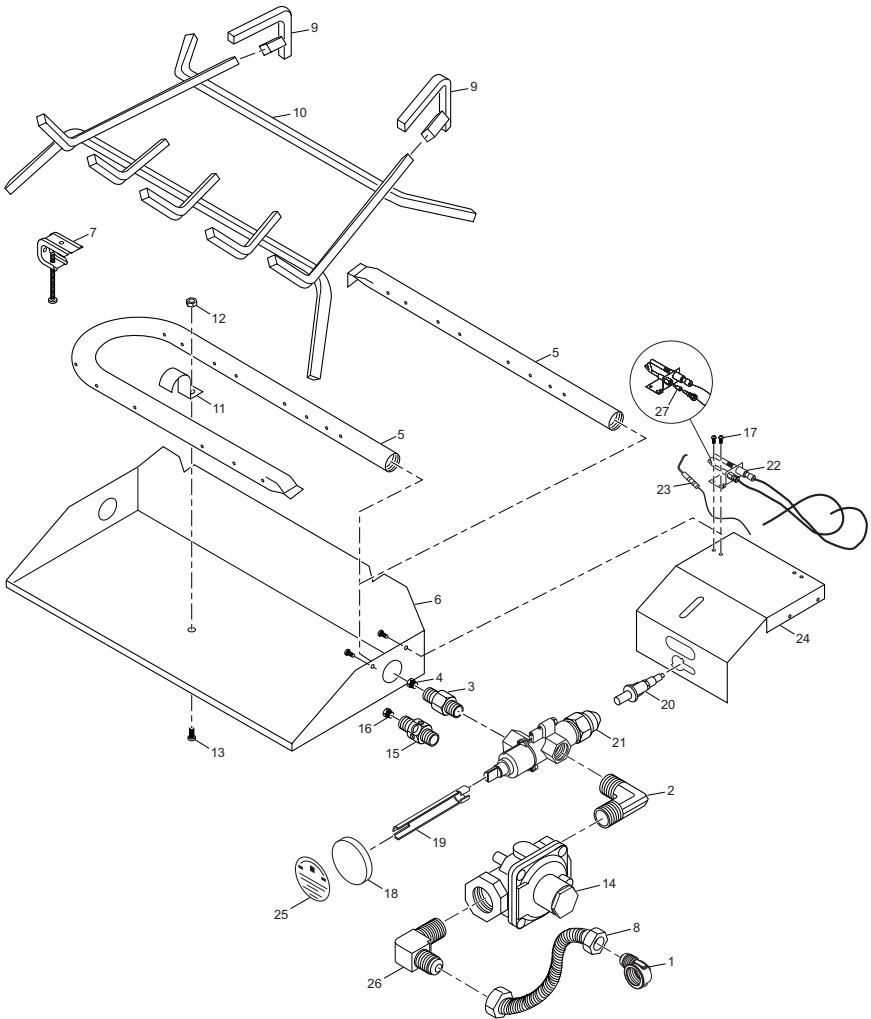
- Shut off gas supply.
- Do not try to light any appliance.
- Do not touch any electrical switch; do not use any phone in your building.
- Immediately call your gas supplier from a neighbor's phone. Follow the gas supplier's instructions.
- If you cannot reach your gas supplier, call the fire department.

*IMPORTANT:* Operating log set where impurities in air exist may create odors. Cleaning supplies, paint, paint remover, cigarette smoke, cements and glues, new carpet or textiles, etc., create fumes. These fumes may mix with combustion air and create odors. These odors will disappear over time.

OBSERVED PROBLEM	POSSIBLE CAUSE	REMEDY
Log set produces a clicking/ticking noise just after burner is lit or shut off.	1. Metal expanding while heating or contracting while cooling.	1. This is normal with most log sets. If noise is excessive, contact qualified service person.
Log set produces unwanted odors.	1. Log Set burning vapors from paint, hair spray, glues, cleaners, chemicals, new carpet, etc. (See <i>IMPORTANT</i> statement above.) 2. Gas leak. <b>See Warning statement at top of page.</b>	1. Open flue to maximum. Stop using odor causing products while log set is running. 2. Locate and correct all leaks (see <i>Checking Gas Connections</i> , page 7).
Gas odor even when control knob is in OFF position.	1. Gas leak. <b>See Warning statement at top of page.</b> 2. Control valve defective.	1. Locate and correct all leaks (see <i>Checking Gas Connections</i> , page 7). 2. Replace control valve.
Gas odor during combustion.	1. Gas leak. <b>See Warning statement at top of page.</b>	1. Locate and correct all leaks (see <i>Checking Gas Connections</i> , page 7).

# PARTS

MODELS VVSA18M, VVSA24M, VVDA18M, VVDA24M AND VVDA30M





## PARTS

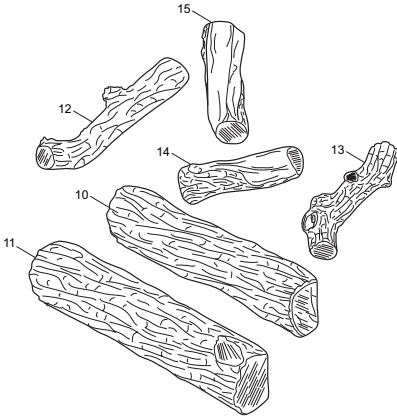
This list contains replaceable parts used in your log set. When ordering parts, follow the instructions listed under Replacement Parts on page 22 of this manual.

KEY NO.	PART NO.	DESCRIPTION	VISA18M	VISA24M	VDA18M	VDA24M	VDA30M	QTY.
1	14325	Brass 3/8 FLR x 1/2 FPT	•	•	•	•	•	1
2	14528	Brass 3/8 FLR x 3/8 MPT Elbow	•	•	•	•	•	1
3	901066-01	Brass Air Mixer - Natural Gas	•	•	•	•	•	1
4	901064-07	Natural Gas Injector	•	•				1
	901064-02	Natural Gas Injector		•				1
	901064-08	Natural Gas Injector			•			1
	901064-04	Natural Gas Injector				•		1
	901065-06	Propane/LP Brass Orifice	•	•				1
	901065-05	Propane/LP Brass Orifice		•				1
	901065-03	Propane/LP Brass Orifice			•			1
	901065-04	Propane/LP Brass Orifice				•		1
5	901208-01	Burner Manifold	•	•				1
	901208-02	Burner Manifold		•	•			1
	901209-03	Burner Manifold				•		1
6	901136-01	Burner Pan	•					1
	901136-02	Burner Pan		•				1
	901137-01	Burner Pan			•			1
	901137-02	Burner Pan				•		1
	901137-03	Burner Pan					•	1
7	901242-01	Damper Clamp - Std. Assembly	•	•	•	•	•	1
8	901232-01	Gas Line - 12" Aluminum	•	•	•	•	•	1
9	901430-01	Grate Steps	•	•	•	•	•	2
10	901243-01	Log Grate	•					1
	901243-02	Log Grate		•				1
	901246-01	Log Grate			•			1
	901246-02	Log Grate				•		1
	901246-03	Log Grate					•	1
11	901681-01	Burner Strap			•	•	•	1
12	901078-01	Nut #8/32			•	•	•	1
13	901076-01	Screw #8/32 x 3/8			•	•	•	1
14	901082-01	Regulator	•	•	•	•	•	1
15	901066-02	Propane/LP Brass Air Mixer	•	•	•	•	•	1
16	901065-06	Propane/LP Brass Orifice	•					1
	901065-05	Propane/LP Brass Orifice		•	•			1
	901065-03	Propane/LP Brass Orifice			•			1
	901065-04	Propane/LP Brass Orifice				•		1
17	901075-01	Screw 1/4" #8 "B" pt	•	•	•	•	•	4
18	901079-01	Pilot Valve Control Dial	•	•	•	•	•	1
19	901080-01	Pilot Valve Dial Extension 3"	•	•	•	•	•	1
20	097159-04	Piezo Igniter	•	•	•	•	•	1
21	901068-02	Manual Valve	•	•	•	•	•	1
22	901069-01	Pilot Burner (with natural gas orifice)	•	•	•	•	•	1
23	901072-01	Piezo Igniter Electrode	•	•	•	•	•	1
24	901140-01	Steel Shroud	•	•	•	•	•	1
25	901042-01	Control Dial Instructions	•	•	•	•	•	1
26	14264	Brass 3/8 FLR x 3/8 MPT Elbow	•	•	•	•	•	1
27	901070-01	Propane/LP Pilot Burner Orifice	•	•	•	•	•	1
<b>PARTS AVAILABLE — NOT SHOWN</b>								
	901156-01	0.5# Bag Embers	•	•	•	•	•	1
	901155-01	1.5# Bag Ash Bed Material (Vermiculite)	•	•	•	•	•	1

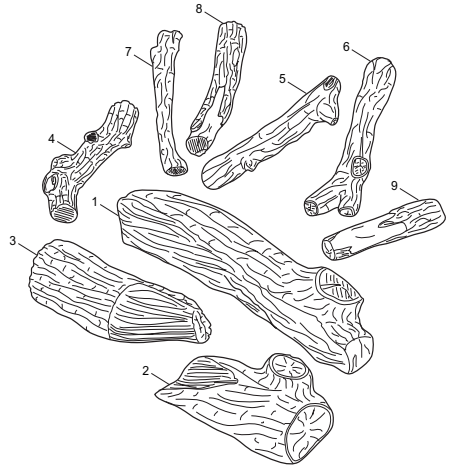
## PARTS

This list contains replaceable parts used in your log set. When ordering parts, follow the instructions listed under Replacement Parts on page 22 of this manual.

### HANOVER ROUND OAK LOG MODELS VSLR18 AND VSLR24



### KINGSTON SPLIT OAK LOG MODELS VDLCR18, VDLCR24 AND VDLCR30



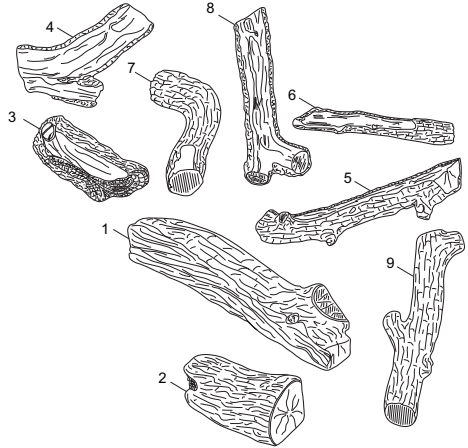
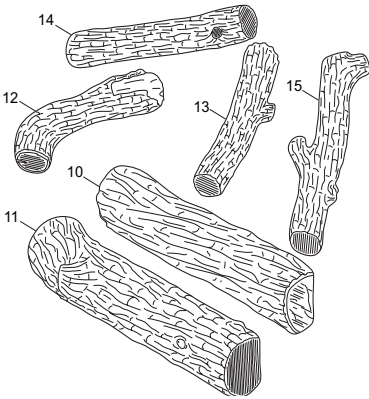
KEY NO.	PART NO.	DESCRIPTION						QTY.
			VSLR18	VSLR24	VDLCR18	VDLCR24	VDLCR30	
1	901565-02	Bottom Rear			•			1
	901566-02	Bottom Rear				•		1
	901567-02	Bottom Rear					•	1
2	901603-01	Bottom Front Right			•			1
	901604-01	Bottom Front Right				•		1
	901604-04	Bottom Front Right					•	1
3	901593-01	Bottom Front Left			•			1
	901594-01	Bottom Front Left				•		1
	901595-01	Bottom Front Left					•	1
4	901580-02	VR-11\VC Top Log					•	1
5	901588-01	VS-12 Top Log			•	•	•	1
6	901592-01	VCR-12 Top Log				•	•	1
7	901591-02	VCR-11\VC Top Log			•	•	•	1
8	901551-03	CHR-13\VC Top Log				•	•	1
9	901587-01	VCR-9 Top Log				•	•	1
10	901625-03	Bottom Rear	•					1
	901626-03	Bottom Rear		•				1
11	901583-01	Bottom Front	•					1
	901584-01	Bottom Front		•				1
12	901541-02	CPR-13\VR Top Log	•	•				1
13	901580-01	VR-11\VR Top Log	•	•				1
14	901579-01	VR-10Y Top Log	•	•				1
15	901578-01	VR-10 Top Log		•				1

## PARTS

This list contains replaceable parts used in your log set. When ordering parts, follow the instructions listed under Replacement Parts on page 22 of this manual.

### ARLINGTON ROUND OAK LOG MODELS FSLR18, FSLR24

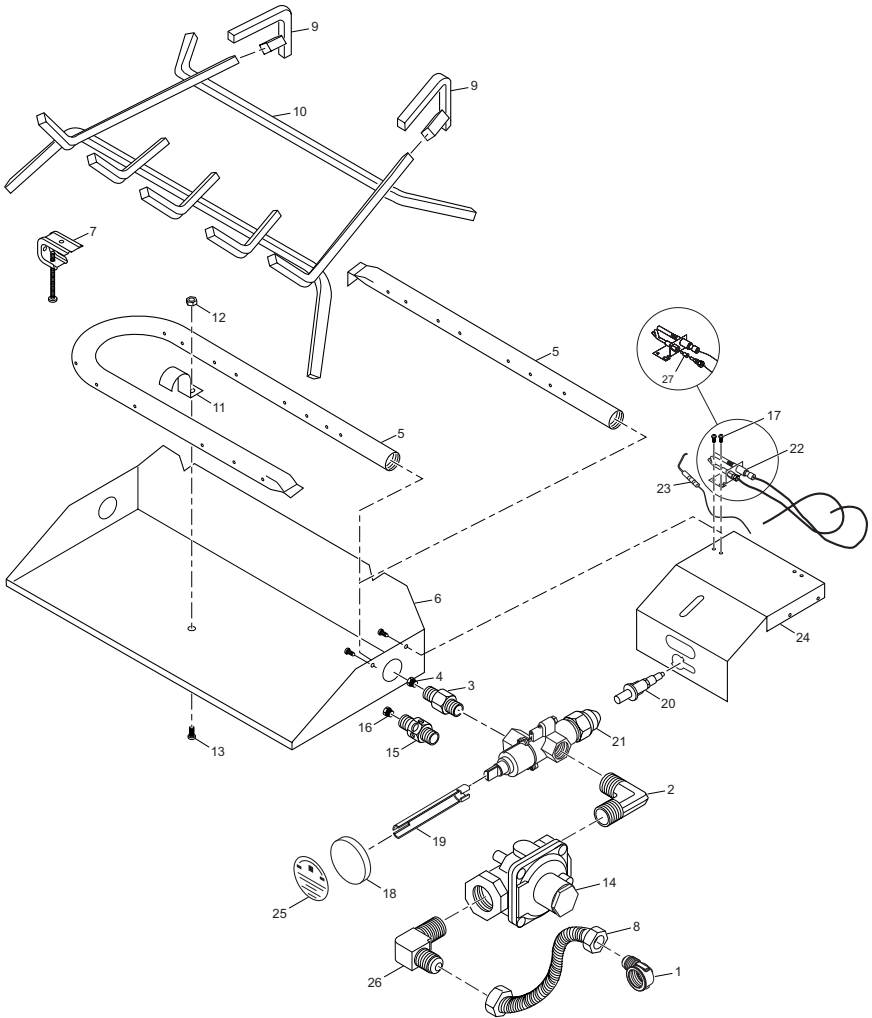
### MANCHESTER SPLIT OAK LOG MODELS FDLR18, FDLR24 AND FDLR30



KEY NO.	PART NO.	DESCRIPTION						QTY.
			FSLR18	FSLR18	FSLR18	FSLR18	FSLR18	
1	901565-03	Bottom Rear Log			•			1
	901566-03	Bottom Rear Log				•		1
	901567-03	Bottom Rear Log					•	1
2	901656-01	Bottom Front Log, Rt			•			1
	901657-01	Bottom Front Log, Rt				•		1
	901658-01	Bottom Front Log, Rt					•	1
3	901666-01	Bottom Front Log, Lt			•			1
	901667-01	Bottom Front Log, Lt				•		1
	901668-01	Bottom Front Log, Lt					•	1
4	901619-01	FS-12Y Top Log			•	•	•	1
5	901617-01	FS-16 Top Log			•	•	•	1
6	901612-01	FS-17 Top Log			•	•	•	1
7	901620-02	FR12L Top Log			•	•	•	1
8	901614-01	FS15 Top Log				•	•	1
9	901623-02	FR14 Top Log					•	1
10	901625-01	Bottom Rear Log	•					1
	901626-01	Bottom Rear Log		•				1
11	901635-01	Bottom Front Log	•					1
	901636-01	Bottom Front Log		•				1
12	901620-01	FR12L Top Log	•	•				1
13	901622-01	FR11 Top Log	•	•				1
14	901547-01	CPR11 Top Log			•			1
15	901623-01	FR14 Top Log	•	•				1

# PARTS

MODELS FVSA18M, FVSA24M, FVDA18M, FVDA24M AND FVDA30M



## PARTS

This list contains replaceable parts used in your log set. When ordering parts, follow the instructions listed under Replacement Parts on page 22 of this manual.

KEY NO.	PART NO.	DESCRIPTION						QTY.
			FVSA18M	FVSA24M	FVDA18M	FVDA24M	FVDA30M	
1	14325	Brass 3/8 FLR x 1/2 FPT	.	.	.	.	.	1
2	14528	Brass 3/8 FLR x 3/8 MPT Elbow	.	.	.	.	.	1
3	901066-01	Brass Air Mixer - Natural Gas	.	.	.	.	.	1
4	901064-07	Natural Gas Injector	.	.	.	.	.	1
	901064-02	Natural Gas Injector	.	.	.	.	.	1
	901064-08	Natural Gas Injector	.	.	.	.	.	1
	901064-04	Natural Gas Injector	.	.	.	.	.	1
5	901208-01	Burner Manifold	.	.	.	.	.	1
	901208-02	Burner Manifold	.	.	.	.	.	1
	901209-01	Burner Manifold	.	.	.	.	.	1
	901209-02	Burner Manifold	.	.	.	.	.	1
	901209-03	Burner Manifold	.	.	.	.	.	1
6	901136-01	Burner Pan	.	.	.	.	.	1
	901136-02	Burner Pan	.	.	.	.	.	1
	901137-01	Burner Pan	.	.	.	.	.	1
	901137-02	Burner Pan	.	.	.	.	.	1
	901137-03	Burner Pan	.	.	.	.	.	1
7	901242-01	Damper Clamp - Std. Assembly	.	.	.	.	.	1
8	901232-01	Gas Line - 12" Aluminum	.	.	.	.	.	1
9	901430-01	Grate Steps	.	.	.	.	.	2
	901431-01	Grate Steps	.	.	.	.	.	2
10	901243-01	Log Grate	.	.	.	.	.	1
	901243-02	Log Grate	.	.	.	.	.	1
	901246-01	Log Grate	.	.	.	.	.	1
	901246-02	Log Grate	.	.	.	.	.	1
	901246-03	Log Grate	.	.	.	.	.	1
11	901681-01	Burner Strap	.	.	.	.	.	1
12	901078-01	Nut #8/32	.	.	.	.	.	1
13	901076-01	Screw #8/32 x 3/8	.	.	.	.	.	1
14	901082-01	Regulator	.	.	.	.	.	1
15	901066-02	Propane/LP Brass Air Mixer	.	.	.	.	.	1
16	901065-06	Propane/LP Brass Orifice	.	.	.	.	.	1
	901065-05	Propane/LP Brass Orifice	.	.	.	.	.	1
	901065-03	Propane/LP Brass Orifice	.	.	.	.	.	1
	901065-04	Propane/LP Brass Orifice	.	.	.	.	.	1
17	901075-01	Screw 1/4" #8 "B" pt	.	.	.	.	.	2
18	901079-01	Pilot Valve Control Dial	.	.	.	.	.	1
19	901080-01	Pilot Valve Dial Extension 3"	.	.	.	.	.	1
20	097159-04	Piezo Igniter	.	.	.	.	.	1
21	901068-02	Manual Valve	.	.	.	.	.	1
22	901069-01	Pilot Burner (with natural gas orifice)	.	.	.	.	.	1
23	901072-01	Piezo Igniter Electrode	.	.	.	.	.	1
24	901140-01	Steel Shroud	.	.	.	.	.	1
25	901042-01	Control Dial Instructions	.	.	.	.	.	1
26	14264	Brass 3/8 FLR x 3/8 MPT Elbow	.	.	.	.	.	1
27	901070-01	Propane/LP Pilot Burner Orifice	.	.	.	.	.	1
<b>PARTS AVAILABLE — NOT SHOWN</b>								
	901156-01	0.5# Bag Embers	.	.	.	.	.	1
	901155-01	1.5# Bag Ash Bed Material (Vermiculite)	.	.	.	.	.	1

## REPLACEMENT PARTS

*Note: Use only original replacement parts. This will protect your warranty coverage for parts replaced under warranty.*

### PARTS UNDER WARRANTY

Contact authorized dealers of this product. If they can't supply original replacement part(s), call DESA Heating, LLC at 1-866-672-6040. When calling DESA Heating, LLC, have ready:

- your name
- your address
- model and serial numbers of your heater
- how heater was malfunctioning
- purchase date

Usually, we will ask you to return the part to the factory.

### PARTS NOT UNDER WARRANTY

Contact authorized dealers of this product. If they can't supply original replacement part(s), call DESA Heating, LLC at 1-866-672-6040 for referral information. A list of authorized dealers can be found by visiting [www.desatech.com](http://www.desatech.com). When calling DESA Heating, LLC, have ready:

- model and serial numbers of your heater
- the replacement part number

## ACCESSORIES

Purchase these accessories from your local dealer. If they can not supply these accessories call DESA Heating, LLC at 1-866-672-6040 for information. You can also write to the address listed on the back page of this manual.

### ASH BED MATERIAL (VERMICULITE) - GA9750A

**For all models.** Carton of 6.

### GLOWING EMBERS - GA9950A

**For all models.** Use for firebox decoration only.

### SILICA SAND - GA9850A

**For all models.** Use for firebox decoration only. Carton of 6.

### LAVA ROCK - GA6067A

**For all models.** Use for firebox decoration only.

### DECORATIVE ASH BED CONTROL COVER CDABKA

**For all models.** An attractive way to cover control knob and piezo ignitor.

### 6" EXTENSION ROD - 901080-03

**For all models.** Use as replacement for 3" extension rod provided with logset.

### RECEIVER AND HAND-HELD REMOTE CONTROL KIT - HRC100 SERIES

**For all models.** Allows the gas log heater to be turned on and off by using a hand-held remote control.

### WALL MOUNTED THERMOSTAT CONTROL KIT - GWMT1

**For all models.** Allows easy wall access to the operation of your burner system. This will allow you thermostatic control with the convenience of a wall switch.

### WALL MOUNTED ON/OFF SWITCH GWMS2

**For all models.** Allows burner system to be turned on and off with a wall switch.

### PINE CONES - GA9650A

**For all models.** Use for additional decoration only. (3 pine cones per box).

### PILOT ADAPTOR KIT - GA9152

**For all models.** Allows conversion from natural gas to propane/LP gas. Also includes everything you need to mount controls for logset under firebox refractory.



---

---

# WARRANTY

---

---

## KEEP THIS WARRANTY

Model (located on product or identification tag) \_\_\_\_\_

Serial No. (located on product or identification tag) \_\_\_\_\_

Date Purchased \_\_\_\_\_

Keep receipt for warranty verification.

## DESA HEATING, LLC LIMITED WARRANTIES

### New Products

**Standard Warranty:** DESA Heating, LLC warrants this new product and any parts thereof to be free from defects in material and workmanship for a period of four (4) years from the date of first purchase from an authorized dealer provided the product has been installed, maintained and operated in accordance with DESA Heating, LLC's warnings and instructions.

For products purchased for commercial, industrial or rental usage, this warranty is limited to 90 days from the date of first purchase.

### Factory Reconditioned Products

**Limited Warranty:** DESA Heating, LLC warrants factory reconditioned products and any parts thereof to be free from defects in material and workmanship for 30 days from the date of first purchase from an authorized dealer provided the product has been installed, maintained and operated in accordance with DESA Heating, LLC's warnings and instructions.

### Terms Common to All Warranties

The following terms apply to all of the above warranties:

Always specify model number and serial number when contacting the manufacturer. To make a claim under this warranty the bill of sale or other proof of purchase must be presented.

This warranty is extended only to the original retail purchaser when purchased from an authorized dealer, and only when installed by a qualified installer in accordance with all local codes and instructions furnished with this product.

This warranty covers the cost of part(s) required to restore this product to proper operating condition and an allowance for labor when provided by a DESA Heating, LLC Authorized Service Center or a provider approved by DESA Heating, LLC. Warranty parts must be obtained through authorized dealers of this product and/or DESA Heating, LLC who will provide original factory replacement parts. Failure to use original factory replacement parts voids this warranty.

Travel, handling, transportation, diagnostic, material, labor and incidental costs associated with warranty repairs, unless expressly covered by this warranty, are not reimbursable under this warranty and are the responsibility of the owner.

Excluded from this warranty are products or parts that fail or become damaged due to misuse, accidents, improper installation, lack of proper maintenance, tampering, or alteration(s).

This is DESA Heating, LLC's exclusive warranty, and to the full extent allowed by law; this express warranty excludes any and all other warranties, express or implied, written or verbal and limits the duration of any and all implied warranties, including warranties of merchantability and fitness for a particular purpose to four (4) years on new products and 30 days on factory reconditioned products from the date of first purchase. DESA Heating, LLC makes no other warranties regarding this product.

DESA Heating, LLC's liability is limited to the purchase price of the product, and DESA Heating, LLC shall not be liable for any other damages whatsoever under any circumstances including indirect, incidental, or consequential damages.

Some states do not allow limitations on how long an implied warranty lasts or the exclusion or limitation of incidental or consequential damages, so the above limitation or exclusion may not apply to you.

This warranty gives you specific legal rights, and you may also have other rights which vary from state to state.

For information about this warranty contact:



124184 01

NOT A UPC



DESA Heating, LLC  
2701 Industrial Drive  
Bowling Green, KY 42101

[www.desatech.com](http://www.desatech.com)

1-866-672-6040

124184-01

Rev. B

12/08