

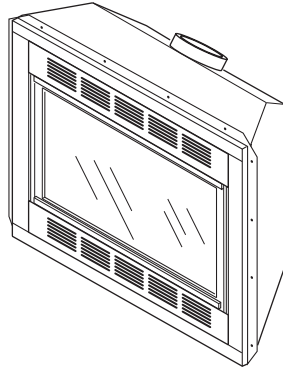

**FMI PRODUCTS, LLC  
DIRECT-VENT FIREPLACE  
OWNER'S OPERATION AND INSTALLATION MANUAL**



**NATURAL GAS “TUDOR” MODELS (V)T32N-A, AND (V)TC32N  
SERIES, CGDV32NR AND CTDV32NR-HA  
PROPANE/LP GAS “TUDOR” MODELS (V)T32P-A, AND (V)TC32P  
SERIES AND CGDV32PR**

**⚠ WARNING:** If the information in this manual is not followed exactly, a fire or explosion may result causing property damage, personal injury or loss of life.

- Do not store or use gasoline or other flammable vapors and liquids in the vicinity of this or any other appliance.
- **WHAT TO DO IF YOU SMELL GAS**
  - Do not try to light any appliance.
  - Do not touch any electrical switch; do not use any phone in your building.
  - Immediately call your gas supplier from a neighbor's phone. Follow the gas supplier's instructions.
  - If you cannot reach your gas supplier, call the fire department.
- Installation and service must be performed by a qualified installer, service agency or the gas supplier.

**INSTALLER:** Leave this manual with the appliance.  
**CONSUMER:** Retain this manual for future reference.

## TABLE OF CONTENTS

Safety .....	2	Operation .....	28
Product Identification .....	5	Inspecting Burners .....	30
Local Codes .....	5	Cleaning and Maintenance .....	31
Product Features .....	5	Replacement Parts .....	33
Pre-Installation Preparation .....	6	Service Hints .....	33
Location of Termination Cap .....	8	Technical Service .....	33
Requirements for the Commonwealth of Massachusetts .....	9	Specifications .....	33
Venting Installation .....	10	Troubleshooting .....	34
Fireplace Installation .....	19	Parts .....	38
		Accessories .....	42
		Warranty .....	Back Cover

## SAFETY

**⚠ WARNING:** Improper installation, adjustment, alteration, service or maintenance can cause injury or property damage. Refer to this manual for correct installation and operational procedures. For assistance or additional information consult a qualified installer, service agency or the gas supplier.

**State of Massachusetts:** The installation must be made by a licensed plumber or gas fitter in the Commonwealth of Massachusetts.

**⚠ WARNING:** This product contains and/or generates chemicals known to the State of California to cause cancer or birth defects or other reproductive harm.

This appliance may be installed in an aftermarket,\* permanently located, manufactured (mobile) home, where not prohibited by local codes.

**IMPORTANT:** Read this owner's manual carefully and completely before trying to assemble, operate or service this fireplace. Improper use of this fireplace can cause serious injury or death from burns, fire, explosions, electrical shock and carbon monoxide poisoning.

This appliance is only for use with the type of gas indicated on the rating plate. This appliance is not convertible for use with other gases, unless a certified kit is used.

**⚠ DANGER:** Carbon monoxide poisoning may lead to death!

This fireplace complies with the National Safety Standards and is listed and tested by PFS Corporation to ANSI Z21.50/CSA 2.22 standard as vented gas fireplace.

**NOTICE:** Decorative product not for use as a heating appliance.

\* Aftermarket: Completion of sale, not for purpose of resale, from the manufacturer

## SAFETY

### Continued

This fireplace must be installed by a qualified (certified or licensed) service person. It has a sealed gas combustion chamber that uses a coaxial pipe (pipe within a pipe and having the same center) venting system. It brings in fresh air for combustion through the outer pipe and combustion gases are exhausted through the inner pipe. If the glass door assembly and venting pipe are not properly seated, connected and sealed, carbon monoxide leakage (spillage) can occur.

**Carbon Monoxide Poisoning:** Early signs of carbon monoxide poisoning resemble the flu, with headaches, dizziness or nausea. If you have these signs, the fireplace may not be working properly. **Get fresh air at once!** Have fireplace serviced. Some people are more affected by carbon monoxide than others. These include pregnant women, people with heart or lung disease or anemia, those under the influence of alcohol and those at high altitudes.

**Natural and Propane/LP Gas:** Natural and propane/LP gases are odorless. An odor-making agent is added to the gas. The odor helps you detect a gas leak. However, the odor added to the gas can fade. Gas may be present even though no odor exists.

Make certain you read and understand all warnings. Keep this manual for reference. It is your guide to safe and proper operation of this fireplace.

 **WARNING: Any change to this fireplace or its controls can be dangerous.**

 **WARNING: Do not use a blower insert, heat exchanger insert or other accessory not approved for use with this fireplace.**

**Do not use any solid fuels (wood, coal, paper, cardboard, etc.) in this fireplace. Use only the gas type indicated on fireplace name plate.**

**Carefully supervise young children when they are in the room with fireplace.**

**This fireplace reaches high temperatures. Keep children and adults away from hot surfaces to avoid burns or clothing ignition. Fireplace will remain hot for a time after shutdown. Allow surfaces to cool before touching.**

### **WARNING**



**HOT GLASS WILL  
CAUSE BURNS.  
DO NOT TOUCH GLASS  
UNTIL COOLED.  
NEVER ALLOW CHILDREN  
TO TOUCH GLASS.**

## SAFETY

*Continued*

**Do not operate fireplace with glass door removed, cracked or broken.**

**Keep the appliance area clear and free from combustible materials, gasoline and other flammable vapors and liquids.**

**Do not place clothing or other flammable material on or near fireplace. Never place any objects on fireplace.**

1. This appliance is only for use with the type of gas indicated on the rating plate. This appliance is not convertible for use with other gases unless a certified kit is used.
2. For propane/LP fireplace, do not place propane/LP supply tank(s) inside any structure. Locate propane/LP supply tank(s) outdoors. To prevent performance problems, do not use propane/LP fuel tank of less than 100 lbs. capacity.
3. If you smell gas
  - shut off gas supply
  - do not try to light any appliance
  - do not touch any electrical switch; do not use any phone in your building
  - immediately call your gas supplier from a neighbor's phone. Follow the gas supplier's instructions
  - if you cannot reach your gas supplier, call the fire department
4. Never install the fireplace
  - in a recreational vehicle
  - in windy or drafty areas where curtains or other combustible (flammable) objects can make contact with the fireplace front
  - in high traffic areas
5. Do not modify this fireplace under any circumstances. Any parts removed for servicing must be replaced prior to operating fireplace.
6. Turn fireplace off and let cool before servicing, installing or repairing. Only a qualified service person should install, service or repair this fireplace. Have fireplace inspected annually by a qualified service person.
7. You must keep control compartments, burners and circulating air passages clean. More frequent cleaning may be needed due to excessive lint and dust from carpeting, bedding material, etc. Turn off the gas valve and pilot light before cleaning fireplace.
8. Have venting system inspected annually by a qualified service person. If needed, have venting system cleaned or repaired. See *Cleaning and Maintenance*, page 31.
9. Do not use this fireplace to cook food or burn paper or other objects.
10. This appliance, when installed, must be electrically grounded in accordance with local codes or, in the absence of local codes, with the *National Electrical Code, ANSI/NFPA 70*.
11. Do not use fireplace if any part has been under water. Immediately call a qualified service person to arrange for replacement of the unit.
12. Do not operate fireplace if log is broken.
13. Provide adequate clearances around air openings.

## PRODUCT IDENTIFICATION

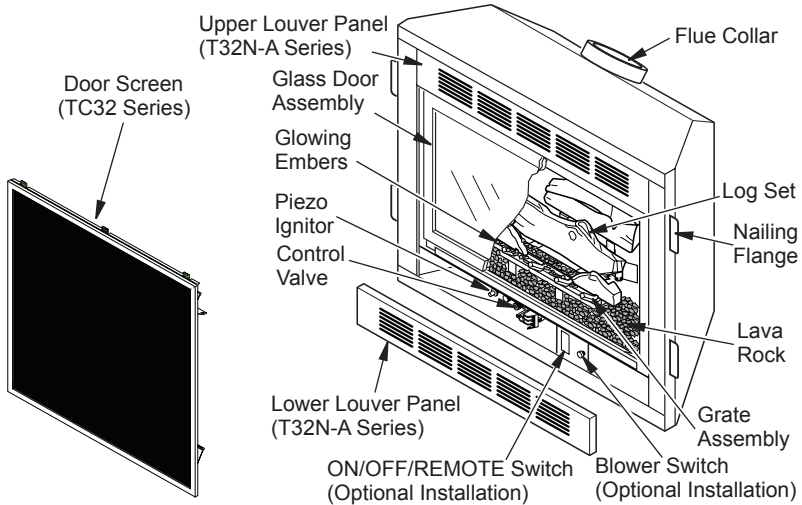

**Figure 1 - Direct-Vent Fireplace with Millivolt Ignition**

## LOCAL CODES

Install and use fireplace with care. Follow all local codes. In the absence of local codes, use the current *National Fuel Gas Code ANSI Z223.1/NFPA 54\**.

\*Available from:

American National Standards Institute, Inc.  
1430 Broadway  
New York, NY 10018

National Fire Protection Association, Inc.  
Batterymarch Park  
Quincy, MA 02269

## PRODUCT FEATURES

These are a few facts that can help you understand and enjoy your direct-vent fireplace:

- The venting system may be routed to the outside of your home in several ways. It may vent through the roof (vertical) or it may vent to an outside/exterior wall (horizontal). The vent pipe installation is very important to allow for proper operation. You must follow the venting instructions very carefully for either vertical or horizontal applications.
- This fireplace may be installed in any room of your house provided all local codes and these installation instructions are followed.
- This fireplace does not require electricity to operate.
- Only the blower requires electricity if installed. If you plan to install the blower at a later date, outlet must be wired at the bottom of the fireplace when framing.
- A piezo ignitor and ceramic electrode create sparks to ignite the pilot light. It does not require any matches, batteries or any other sources of ignition to light the pilot.
- Each time you turn on your fireplace, you may notice some amount of condensation on the inside of the fireplace glass. This is normal and will disappear after 10-20 minutes of operation.
- Your direct-vent gas fireplace system (fireplace and venting) is a balanced and sealed gas operating unit. It requires approximately 10-20 minutes of operating time before the flame pattern stabilizes.
- Fireplaces with the suffix of -HA have been designed to operate at altitudes of 4000 feet and above.

## PRE-INSTALLATION PREPARATION

### LOCATION AND SPACE REQUIREMENTS

Determine the safest and most efficient location for your FMI PRODUCTS, LLC direct-vent fireplace. Make sure that rafters and wall studs are not in the way of the venting system. Choose a location where the heat output is not affected by drafts, air conditioning ducts, windows or doors. Figure 2 shows some common locations. Be aware of all restrictions and precautions before deciding the exact location for your fireplace and termination cap.

When deciding the location of your fireplace, follow these rules:

- Do not connect this fireplace venting to a chimney flue serving a separate solid-fuel burning fireplace or appliance.
- Due to high temperatures, do not locate this fireplace in high traffic areas, windy or drafty areas or near furniture or draperies.
- Proper clearances must be maintained.
- If your fireplace is to be installed directly on carpeting, vinyl tile or any combustible material other than wood, it must be installed on a metal or wood panel extending the full width and depth of the fireplace. See Figure 3.
- Your fireplace is designed to be used in zero clearance installations. Wall or framing material can be placed directly against any exterior surface on the back, sides or top of your fireplace, except where standoff spacers are integrally attached. If standoff spacers are attached to your fireplace, these spacers can be placed directly against wall or framing material. See framing details on page 6.
- If you plan on installing a television or entertainment center recessed above your fireplace, it is recommended that you maintain a minimum 18" above top of louver opening.
- When locating termination cap, it is important to observe the minimum clearances shown in Figure 7, page 8.
- If recessing into a wall, you can avoid extra framing by positioning your fireplace against an already existing framing member.
- Do not recess termination cap into a wall or siding.
- You may paint the termination cap with 450° F heat-resistant paint to coordinate with the exterior finish.
- There must not be any obstruction such as bushes, garden sheds, fences, decks or utility buildings within 24" from the front of the termination cap.

- Do not locate termination cap where excessive snow or ice build up may occur. Be sure to clear vent termination area after snow falls to prevent accidental blockage of venting system. When using snow blowers, do not direct snow towards vent termination area.
- For horizontal installations above 2,000 feet, it is recommended that a 12" extension pipe be added before starter elbow and a round horizontal termination be used (see *High Altitude Installation*, page 18).

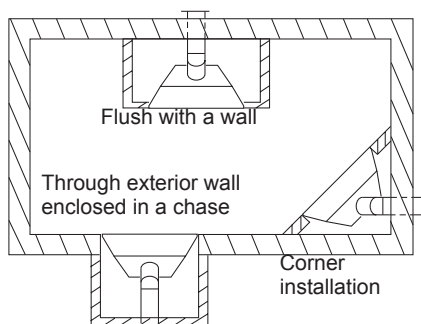

Figure 2 - Common Fireplace Locations

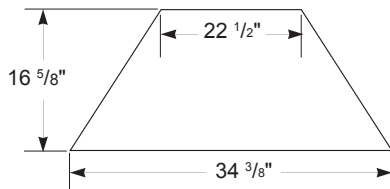

Figure 3 - Fireplace Bottom Dimensions

### CLEARANCES

Minimum clearances to combustibles for the fireplace are as follows:

*Back and sides	0"
Perpendicular walls	6"
Floor	0"
Ceiling to louver opening	42"
Front	36"
Top	0"
Vent	(See venting instructions for specific venting clearances.)

Combustible material with a maximum thickness of 5/8" may be flush with top front of fireplace.

\* For back and sides of fireplace, do not pack with insulation or other materials. 0" clearance to combustible materials are for framing purpose only.

# PRE-INSTALLATION PREPARATION

Continued

**NOTICE:** This fireplace is intended for use as supplemental heat. Use this fireplace along with your primary heating system. Do not install this fireplace as your primary heat source. If you have a central heating system, you may run system's circulating blower while using fireplace. This will help circulate the heat throughout the house. In the event of a power outage, you can use this fireplace as a heat source.

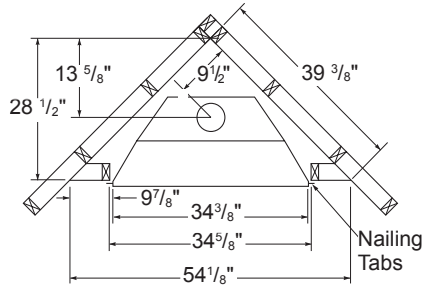

Figure 5 - Framing Clearances for Corner Installation

## FRAMING AND FINISHING

Figure 4 shows typical framing of this fireplace. Figure 5 shows framing for corner installation. All minimum clearances must be met.

For available accessories for this fireplace, see [Accessories](#) on page 42. If you are using a separate combustible mantel piece, refer to Figure 6 for proper installation height. You can install noncombustible mantels at any height above the fireplace. *Note: Noncombustible mantels may discolor!*

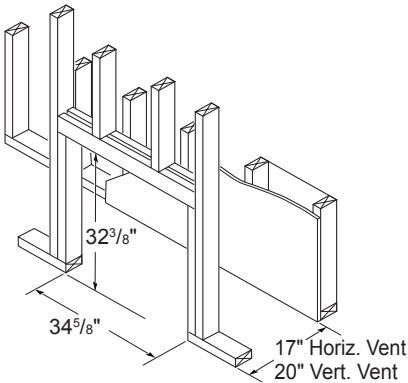
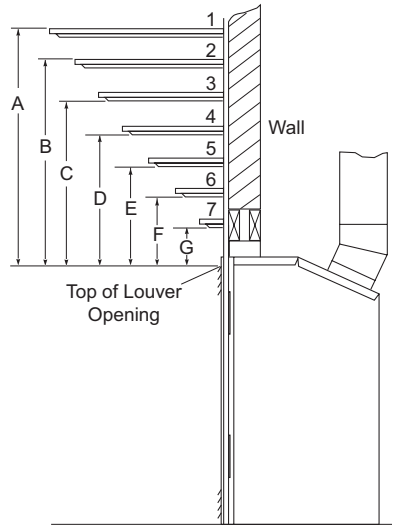

Figure 4 - Framing Clearances for Installation Against an Exterior Wall



Ref.	Mantel Depth	Ref.	Mantel from Top of Louver Opening
1	14"	A	16"
2	12"	B	14"
3	10"	C	12"
4	8"	D	10"
5	6"	E	8"
6	4"	F	6"
7	2"	G	4"

Figure 6 - Clearances for Combustible Mantels

# LOCATION OF TERMINATION CAP

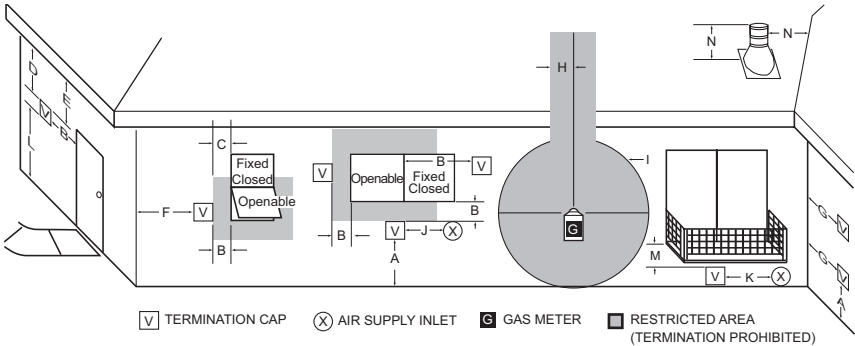

- A = clearance above grade, veranda, porch, deck, or balcony [\*12" (30.5 cm) minimum]
- B = clearance to window or door that may be opened [6" (15 cm) min. for 10,000 Btu or less; 9" (23 cm) in US if between 10,000 and 50,000, 12" (30 cm) in Canada if between 10,000 and 100,000; 12" (30 cm) in US if greater than 50,000, 36" (91 cm) in Canada if greater than 100,000]
- C = clearance to permanently closed window [minimum 12" (30.5 cm) recommended to prevent condensation on window]
- D = vertical clearance to ventilated soffit located above the terminal within a horizontal distance of 24" (61 cm) from the center-line of the terminal [18" (45.7 cm) minimum]
- E = clearance to unventilated soffit [12" (30.5 cm) minimum]
- F = clearance to outside corner (see below)
- G = clearance to inside corner (see below)
- H = \*not to be installed above a meter/regulator assembly within 36" (91.4 cm) horizontally from the center line of the regulator
- I = clearance to service regulator vent outlet [\*72" (182.9 cm) minimum]
- J = clearance to non-mechanical air supply inlet to building or the combustion air inlet to any other fireplace [6" (15 cm) min. for 10,000 Btu or less; 9" (23 cm) in US if between 10,000 and 50,000, 12" (30 cm) in Canada if between 10,000 and 100,000; 12" (30 cm) in US if greater than 50,000, 36" (91 cm) in Canada if greater than 100,000]
- K = clearance to a mechanical air supply inlet [\*In Canada, 6 ft. (1.83m) minimum; In US 3 ft. (91 cm) above if within 10 ft. (3 m) horizontally]
- L = † clearance above paved side-walk or a paved driveway located on public property [\*84" (213.3 cm) minimum]
- M = clearance under veranda, porch, deck [\*12" (30.5 cm) minimum ‡]
- N = clearance above a roof shall extend a minimum of 24" (61 cm) above the highest point when it passes through the roof surface and any other obstruction within a horizontal distance of 18" (45.7 cm)

† vent shall not terminate directly above a side-walk or paved driveway which is located between two single family dwellings and serves both dwellings\*

‡ only permitted if veranda, porch, deck or balcony is fully open on a minimum of 2 sides beneath the floor\*

\* as specified in CAN/CSA B149 (.1 or .2) Installation Codes (1991) for Canada and U.S.A.

Note: Local codes or regulations may require different clearances

## Termination Clearances for Buildings with Combustible and Noncombustible Exteriors

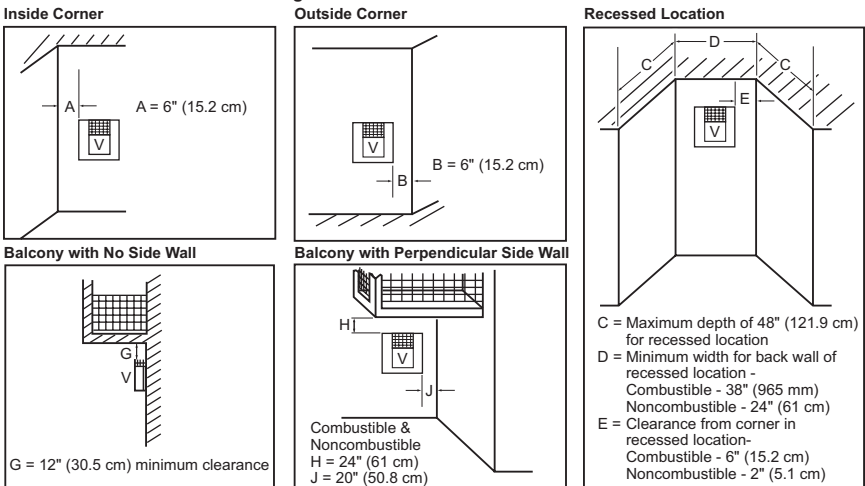

Figure 7 - Minimum Clearances for Termination Cap



# REQUIREMENTS FOR THE COMMONWEALTH OF MASSACHUSETTS

For all side wall horizontally vented gas fueled equipment installed in every dwelling, building or structure used in whole or in part for residential purposes, including those owned or operated by the Commonwealth and where the side wall exhaust vent termination is less than seven (7) feet above finished grade in the area of the venting, including but not limited to decks and porches, the following requirements shall be satisfied:

## INSTALLATION OF CARBON MONOXIDE DETECTORS

At the time of installation of the side wall horizontally vented gas fueled equipment, the installing plumber or gasfitter shall observe that a hard wired carbon monoxide detector with an alarm and battery backup is installed on the floor level where the gas equipment is to be installed. In addition, the installing plumber or gasfitter shall observe that a battery operated or hard wired carbon monoxide detector with an alarm is installed on each additional level of the dwelling, building or structure served by the side wall horizontal vented gas fueled equipment. It shall be the responsibility of the property owner to secure the services of qualified licensed professionals for the installation of hard wired carbon monoxide detectors.

In the event that the side wall horizontally vented gas fueled equipment is installed in a crawl space or an attic, the hard wired carbon monoxide detector with alarm and battery back-up may be installed on the next adjacent floor level.

In the event that the requirements of this subdivision can not be met at the time of completion of installation, the owner shall have a period of thirty (30) days to comply with the above requirements; provided, however, that during said thirty (30) day period, a battery operated carbon monoxide detector with an alarm shall be installed.

### Approved Carbon Monoxide Detectors

Each carbon monoxide detector as required in accordance with the above provisions shall comply with NFPA 720 and be ANSI/UL 2034 listed and IAS certified.

## SIGNAGE

A metal or plastic identification plate shall be permanently mounted to the exterior of the building at a minimum height of eight (8) feet above grade directly in line with the exhaust vent terminal for the horizontally vented gas fueled heating appliance or equipment. The sign shall read, in print size no less than 1/2" in size, "GAS VENT DIRECTLY BELOW. KEEP CLEAR OF ALL OBSTRUCTIONS".

## INSPECTION

The state or local gas inspector of the side wall horizontally vented gas fueled equipment shall not approve the installation unless, upon inspection, the inspector observes carbon monoxide detectors and signage installed in accordance with the provisions of 248 CMR 5.08(2)(a) 1 through 4.

EXEMPTIONS: The following equipment is exempt from 248 CMR 5.08(2)(a) 1 through 4:

- The equipment listed in Chapter 10 entitled "Equipment Not Required To Be Vented" in the most current edition of NFPA 54 as adopted by the Board; and
- Product Approved side wall horizontally vented gas fueled equipment installed in a room or structure separate from the dwelling, building or structure used in whole or in part for residential purposes.

## MANUFACTURER REQUIREMENTS

### Gas Equipment Venting System Provided

When the manufacturer of Product Approved side wall horizontally vented gas equipment provides a venting system design or venting system components with the equipment, the instructions provided by the manufacturer for installation of the equipment and the venting system shall include:

- Detailed instructions for the installation of the venting system design or the venting system components; and
- A complete parts list for the venting system design or venting system.

### Gas Equipment Venting System Not Provided

When the manufacturer of a Product Approved side wall horizontally vented gas fueled equipment does not provide the parts for venting the flue gases, but identifies "special venting systems", the following requirements shall be satisfied by the manufacturer:

- The referenced "special venting system" instructions shall be included with the appliance or equipment installation instructions; and
- The "special venting systems" shall be Product Approved by the Board, and the instructions for that system shall include a parts list and detailed installation instructions.

A copy of all installation instructions for all Product Approved side wall horizontally vented gas fueled equipment, all venting instructions, all parts lists for venting instructions, and/or all venting design instructions shall remain with the appliance or equipment at the completion of the installation.

## VENTING INSTALLATION

**NOTICE: Read these instructions completely before attempting installation.**

These models are tested and approved for use with FMI PRODUCTS, LLC (direct-vent) pipe components and terminations.

The venting system must terminate on the outside of the structure and can not be attached to a chimney or flue system serving a separate solid fuel or gas burning appliance. A direct-vent appliance must have its own venting system. DO NOT common vent this appliance.

These models are approved to be vented either horizontally through an outside wall or vertically through a roof or chase enclosure using the following guidelines:

- When venting system terminates horizontally on an outside wall, you may install a standoff if the termination cap is to be installed directly on a combustible finish such as vinyl, wood, stucco, etc.
- Never run the vent downward as this may cause excessive temperatures which could cause a fire.
- Vent pipe air space clearances to combustibles are 1" on all sides except on the horizontal sections, which requires 2" clearance from the top of the pipe. Where the termination cap penetrates a combustible wall, 1" air space clearance is required.
- Snorkel terminations are required when minimum clearance to grade cannot be met (see Figure 16 on page 14).
- Have fireplace and selected vent components on hand to help determine the exact measurements when elbowing or offsetting. Always use wall firestops when penetrating walls and firestops when penetrating ceilings or attic spaces.
- If using a venting configuration of only horizontal venting with no vertical run, a 1/4" rise for every 12" of run toward the termination is required.
- For installation of fireplace at elevations of 4000 feet or greater, pay special attention to venting requirement recommendations.

**⚠ WARNING: Read all instructions completely and thoroughly before attempting installation. Failure to do so could result in serious injury, property damage or loss of life.**

**NOTICE: Failure to follow these instructions will void the warranty.**

**NOTICE: Do not seal vent cap to pipe. Cap must be removable for service.**

### INSTALLATION PRECAUTIONS

- Wear gloves and safety glasses for protection
- Use extreme caution when using ladders or when on roof tops
- Be aware of electrical wiring locations in walls and ceilings

The following actions will void the warranty on your venting system:

- Installation of any damaged venting component
- Unauthorized modification of the venting system (Do not cut or alter vent components)
- Installation of any component part not manufactured or approved by FMI PRODUCTS, LLC
- Installation other than as instructed by these instructions

**⚠ WARNING: This gas fireplace and vent assembly must be vented directly to the outside. The venting system must NEVER be attached to a chimney serving a separate solid fuel burning appliance. Each direct-vent gas appliance must use a separate vent system. Do not use common vent systems.**

**⚠ WARNING: Vent pipe air space clearances to combustibles are 1" on all sides except on the horizontal sections, which require 2" clearances from the top of the pipe. Where the termination cap penetrates a combustible wall, 1" air space clearance is required.**

# VENTING INSTALLATION

Continued

## INSTALLATION PLANNING

There are two basic types of direct-vent installation:

- Horizontal Termination
- Vertical Termination

### Horizontal Termination Installation

**IMPORTANT:** Horizontal square terminations require only inner portion of wall firestop. Horizontal installations using round termination require exterior portion of wall firestop available only in vent kit HTK (see Figure 14, page 13).

1. Set fireplace in its desired location and determine the route your horizontal venting will take. Do not secure fireplace until all venting has been installed. Some installations require sliding fireplace in and out of position to make final venting connections. Figures 14 through 18 on pages 13 through 15 show different configurations for venting with horizontal termination that will help you decide which application best suits your installation. Check to see if wall studs or roof rafters are in the path of your desired venting route. If they are, you may want to adjust the location of the fireplace.
2. Direct vent pipe sections and components are designed with special twist-lock connections.

**Twist-Lock Procedure:** Female ends of pipes have locking lugs (indentations). These lugs will slide straight into matching slots on male ends of adjacent pipes. Push pipe sections together and twist one section clockwise approximately one-quarter turn until sections are fully locked (see Figure 8). *Note: Horizontal runs of vent must be supported every three feet. Use wall straps for this purpose.*

3. Use a 45° elbow to connect venting system to fireplace flue collar. The elbow is designed to be twist-locked onto flue collar as described in step 2. **IMPORTANT:** Do not attempt to alter configuration of elbow by cutting, twisting, bending, etc.
4. Assemble desired combination of pipe and elbows to fireplace flue collar. If there are long portions of venting run, pre-assembled pipe sections may be installed as subassemblies for convenience.

5. Carefully determine location where vent pipe assembly will penetrate the outside wall. The center of hole should line up with center line of horizontal vent pipe. Mark wall for a 11 1/2" x 11 1/2" square hole. Cut and frame the square hole in exterior wall where vent will be terminated. If wall being penetrated is constructed of noncombustible material, such as masonry block or concrete, a 8 1/2" hole with zero clearance is acceptable (see Figure 9).

**⚠ WARNING: Do not recess vent termination into any wall. This will cause a fire hazard.**

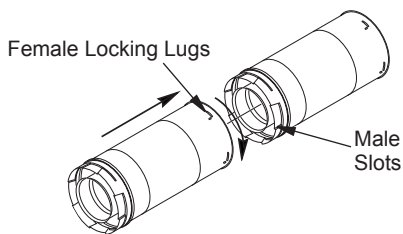

**Figure 8 - Vent Pipe Connections**

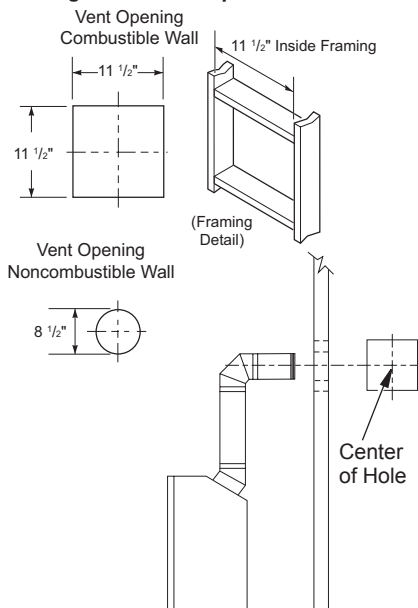

**Figure 9 - Vent Opening Requirements**

# VENTING INSTALLATION

*Continued*

6. **Noncombustible Exterior Wall:** Position horizontal vent cap in center of the 8 1/2" round hole and attach to exterior wall with four screws (see Figure 10). *Note: The four wood screws provided should be replaced with appropriate fasteners for stucco, brick, concrete or other types of sidings.* Before attaching vent cap to exterior wall, run a bead of non-hardening mastic (pliable sealant) around outside edges to make a seal between it and outside wall.

**Combustible Exterior Wall:** For vinyl siding, stucco or wood exteriors, a siding standoff may be installed between vent cap and exterior wall. Siding standoff prevents excessive heat from damaging siding materials. Siding material must be cut to accommodate standoff. Bolt vent cap to standoff. Apply non-hardening mastic around outside edge of standoff. Position standoff/cap assembly in center of the 11 1/2" square hole and attach to exterior wall with wood screws provided (see Figure 11). Siding standoff must sit flush against exterior fascia material.

7. **Connecting Vent Cap with Horizontal Vent Pipe:** Slide wall firestop over vent pipe before connecting horizontal run to vent cap (see Figure 12).

Carefully move fireplace, with vent assembly attached, toward wall and insert vent pipe into horizontal termination. The pipe overlap should be a minimum of 1 1/4" (see Figure 13, page 13).

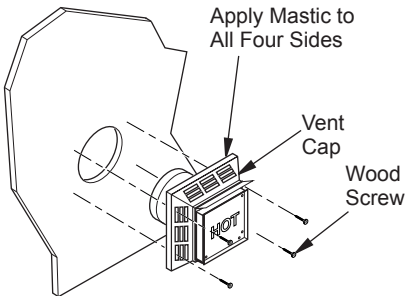

**Figure 10 - Installing Horizontal Vent Cap (Noncombustible Exterior)**

Slide wall firestop against interior wall surface and attach with screws provided (see Figure 12). See Figure 13, page 13, for horizontal termination details.

Place fireplace into position and shim with noncombustible material if needed. Nail or screw side flanges to framing to secure unit in place. **IMPORTANT:** Make sure fireplace is level before securing. If fireplace is not level it will not work properly.

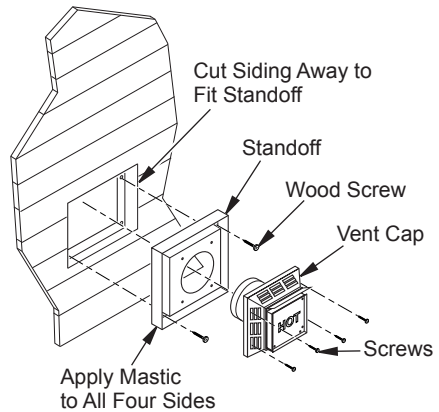

**Figure 11 - Installing Siding Standoff (Combustible Exterior)**

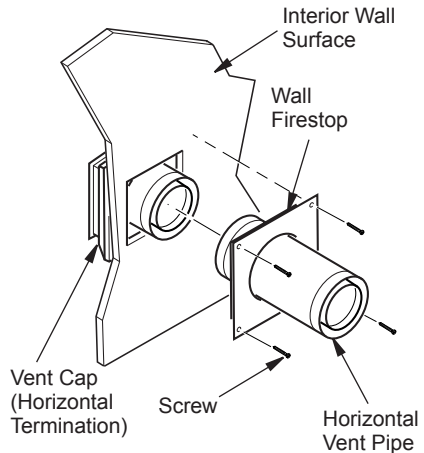

**Figure 12 - Connecting Vent Cap with Horizontal Vent Pipe**

# VENTING INSTALLATION

*Continued*

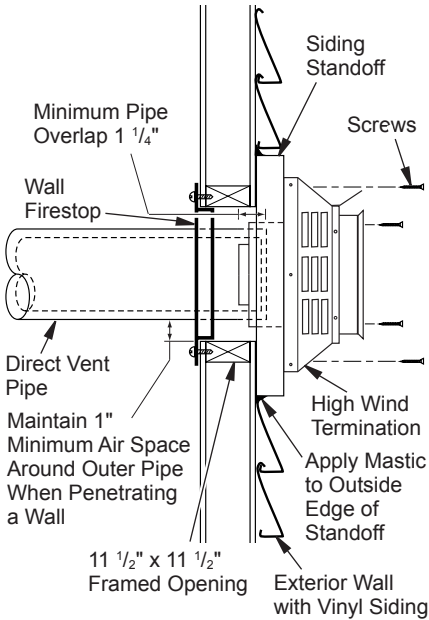

**Figure 13 - Typical Horizontal Termination Cap Mounting with Additional Siding Standoff Installed**

## Horizontal Termination Configurations

Figures 14 through 18 show different configurations and alternatives for venting with horizontal termination. Each figure includes a chart with critical minimum and maximum dimensions which **MUST** be met. **IMPORTANT:** If using a venting configuration of only horizontal venting with no vertical run, a 1/4" rise for every 12" of run toward termination is required.

**NOTICE: Do not seal termination cap to vent pipe. Cap must be removable for vent inspection and maintenance.**

**⚠ WARNING: Never run vent downward as this may cause excessive temperatures which could cause a fire. Operation of improperly installed and maintained venting system could result in serious injury, property damage or loss of life.**

## GROUND FLOOR INSTALLATION

Recommended Applications:

- Installation using cabinet surrounds
- Through the wall using round or square termination (up to 12") adjustable pipe)
- **NOT FOR CORNER INSTALLATION**

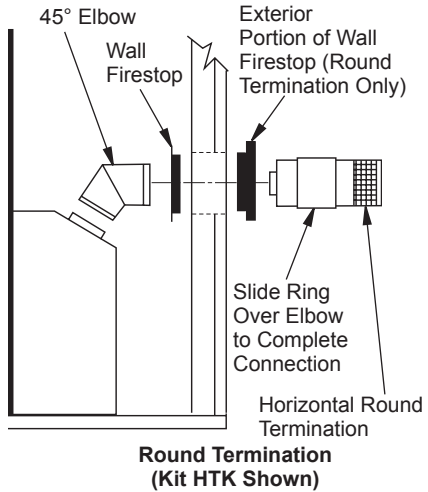
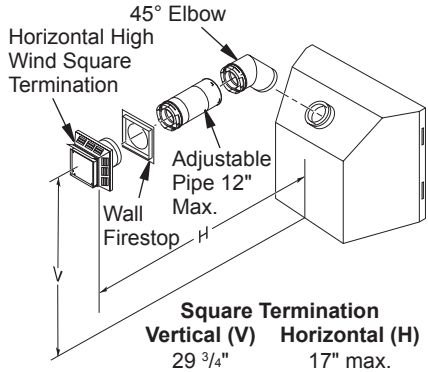

**Figure 14 - Horizontal Termination Configuration for Square or Round Termination**

# VENTING INSTALLATION

Continued

## CORNER INSTALLATION

Recommended Applications:

- Corner ground floor installation
- Ground floor installation where pipe vents horizontally through wall (over 12" horizontal pipe)
- Basement installation where one foot clearance from ground to termination is possible

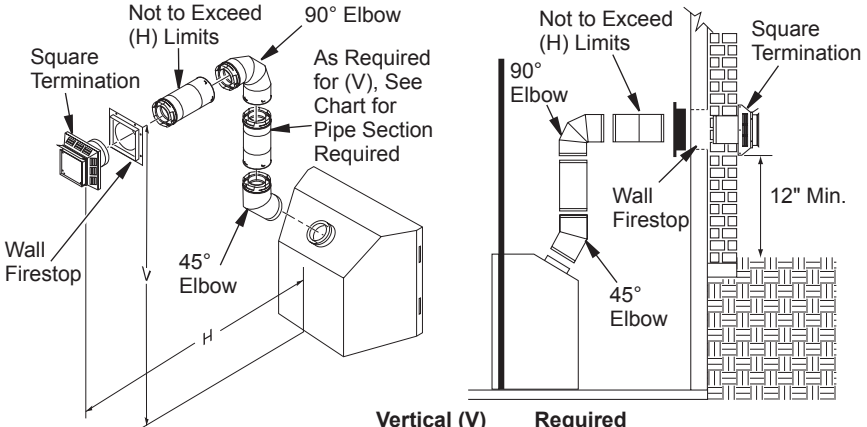

Vertical (V)	Vertical (V) Vertical Pipe	Required Horizontal (H)
*43 3/4" min.	None	30" max.
53 3/4" min.	1 ft.	48" max.
65 3/4" min.	2 ft.	60" max.
77 3/4" min.	3 ft.	84" max.
89 3/4" min.	4 ft.	20' max.

\* Ground Floor Corner Venting

**Figure 15 - Horizontal Termination Configuration for Corner Installation Using One 90° Elbow**

## SNORKEL TERMINATION INSTALLATION

Recommended Applications:

- Installations requiring a vertical rise on building exterior
- Any installation using snorkel termination to achieve one foot above ground

Snorkel terminations are available for installations requiring a vertical rise on exterior of building. If installing snorkel termination below grade, you must provide proper drainage to prevent water from entering snorkel termination (see Figure 16). Do not back fill around snorkel termination.

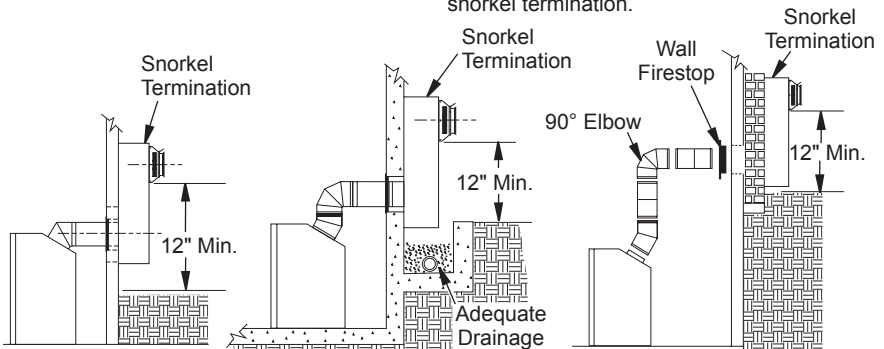

**Figure 16 - Snorkel Termination Configurations for Below Ground Installation**

# VENTING INSTALLATION

*Continued*

## HORIZONTAL SYSTEM INSTALLATION USING TWO 90° ELBOWS

The following configurations show the minimum vertical rise requirements for a horizontal system using two 90° elbows.

### Venting with Two 90° Elbows

Vertical (V)	Horizontal (H <sub>1</sub> )	Horizontal (H <sub>1</sub> ) + Horizontal (H <sub>2</sub> )
5' min.	2' max.	6' max.
6' min.	4' max.	12' max.
7' min.	6' max.	18' max.
8' min.	8' max.	20' max.
20' max.	8' max.	20' max.

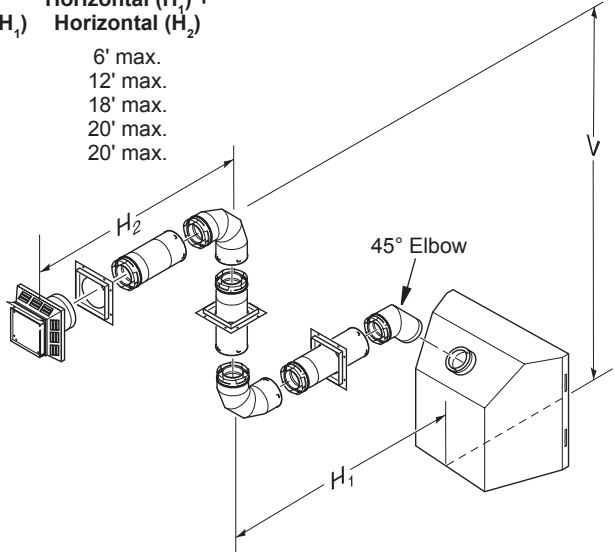

**Figure 17 - Horizontal Termination Configuration for Venting Using Two 90° Elbows**

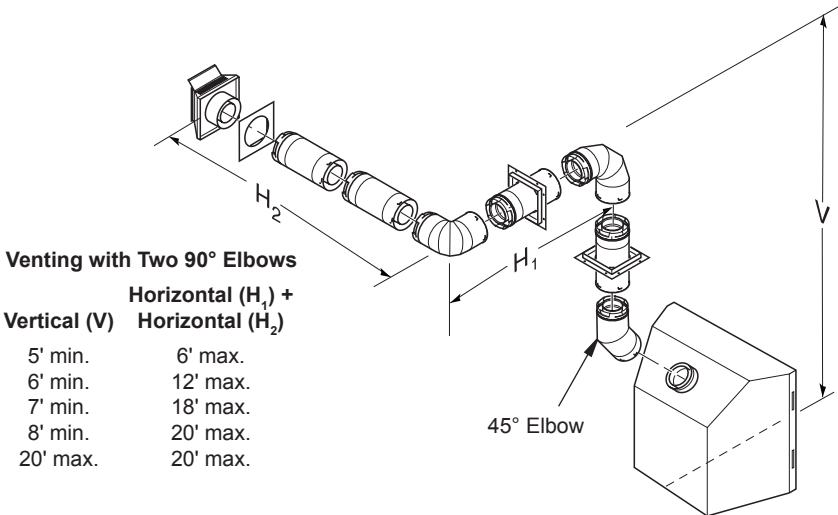

### Venting with Two 90° Elbows

Vertical (V)	Horizontal (H <sub>1</sub> ) + Horizontal (H <sub>2</sub> )
5' min.	6' max.
6' min.	12' max.
7' min.	18' max.
8' min.	20' max.
20' max.	20' max.

**Figure 18 - Horizontal Termination Configuration for Venting Using Two 90° Elbows with Termination at 90° with Fireplace**



# VENTING INSTALLATION

Continued

## INSTALLATION FOR VERTICAL TERMINATION

*Note: Vertical restrictor must be installed in all vertical installations.*

1. Determine route your vertical venting will take. If ceiling joists, roof rafters or other framing will obstruct venting system, consider an offset (see Figure 19) to avoid cutting load bearing members. *Note: Pay special attention to these installation instructions for required clearances (air space) to combustibles when passing through ceilings, walls, roofs, enclosures, attic rafters, etc. Do not pack air spaces with insulation. Also note maximum vertical rise of venting system and any maximum horizontal offset limitations.*
2. Set fireplace in desired location. Drop a plumb line down from ceiling to position of fireplace exit flue. Mark center point where vent will penetrate ceiling. Drill a small locating hole at this point. Drop a plumb line from inside of roof to locating hole in ceiling. Mark center point where vent will penetrate roof. Drill a small locating hole at this point.

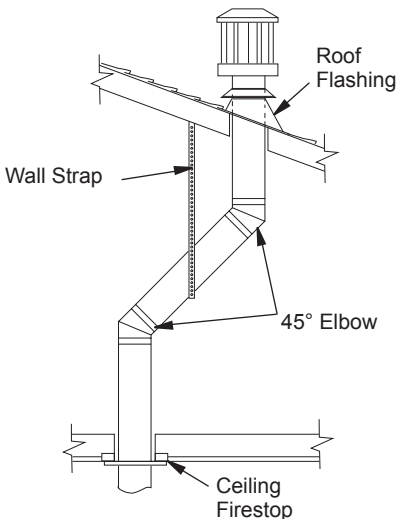

**Figure 19 - Offset with Wall Strap and 45° Elbows**

## Flat Ceiling Installation

1. Cut a 11 1/2" square hole in ceiling using locating hole as a center point. Opening should be framed to 11 1/2" x 11 1/2" inside dimensions, as shown in Figure 9 on page 10 using framing lumber the same size as ceiling joists. If area above the ceiling is an insulated ceiling or an attic, nail firestop from top side. This prevents loose insulation from falling into required clearance space. If area above ceiling is a living space, install firestop below framed hole. Firestop should be installed with no less than 3 nails per side (see Figure 20).
2. Assemble desired lengths of pipe and elbows necessary to reach from fireplace flue up through firestop. Be sure all pipe and elbow connections are fully twist-locked (see Figure 8, page 11).
3. Cut a hole in roof using locating hole as a center point. (Cover any exposed open vent pipes before cutting hole in roof.) The 11 1/2" x 11 1/2" hole must be measured on the horizontal; actual length may be larger depending on pitch of roof. There must be a 1" clearance from vent pipe to combustible materials. Frame opening as shown in Figure 9, page 11.
4. Connect a section of pipe and extend up through hole.

*Note: If an offset is needed to avoid obstructions, you must support vent pipe every 3 feet. Use wall straps for this purpose (see Figure 19). Whenever possible, use 45° elbows instead of 90° elbows. The 45° elbow offers less restriction to the flow of flue gases and intake air.*

5. Place flashing over pipe section(s) extending through roof. Secure base of flashing to roof and framing with roofing nails. Be sure roofing material overlaps top edge of flashing as shown in Figure 19. There must be a 1" clearance from

If area above is an attic or insulated area, install firestop above framed hole.

If area above is a living space, install firestop below framed hole.

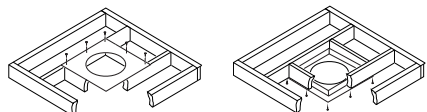

**Figure 20 - Installing Firestop**



# VENTING INSTALLATION

## Continued

vent pipe to combustible materials.

- Continue to add pipe sections until height of vent cap meets the minimum building code requirements described in Figure 7 on page 8. *Note: You must increase vent height for steep roof pitches. Nearby trees, adjoining rooflines, steep pitched roofs and other similar factors may cause poor draft or down-drafting in high winds. Increasing vent height may solve this problem.*

- Twist-lock vent cap onto last section of vent pipe.

*Note: If vent pipe passes through any occupied areas above first floor, including storage spaces and closets, you must enclose pipe. You may frame and sheetrock enclosure with standard construction material. Make sure and meet minimum allowable clearances to combustibles. Do not fill any required air spaces with insulation.*

### Vertical Termination Configurations

Figures 21 through 24 show four different configurations for vertical termination.

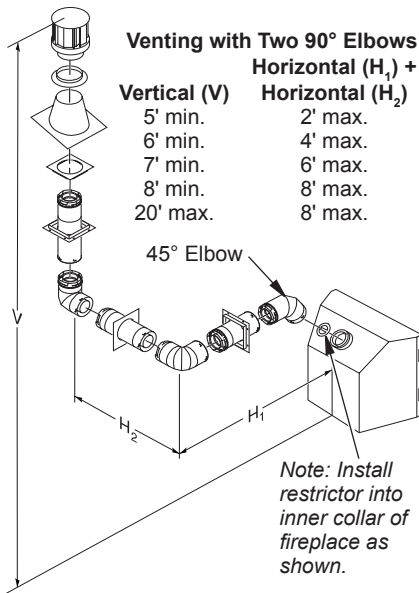

**Figure 21 - Vertical Venting Configuration Using Two 90° Elbows with Two Horizontal Runs (Vertical Round High Wind Termination Shown)**

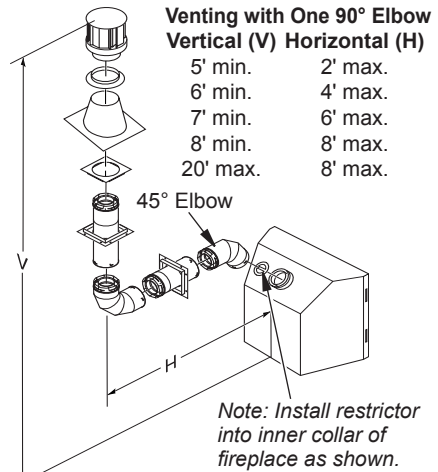

**Figure 22 - Vertical Venting Configuration Using One 90° Elbow (Vertical Round High Wind Termination Shown)**

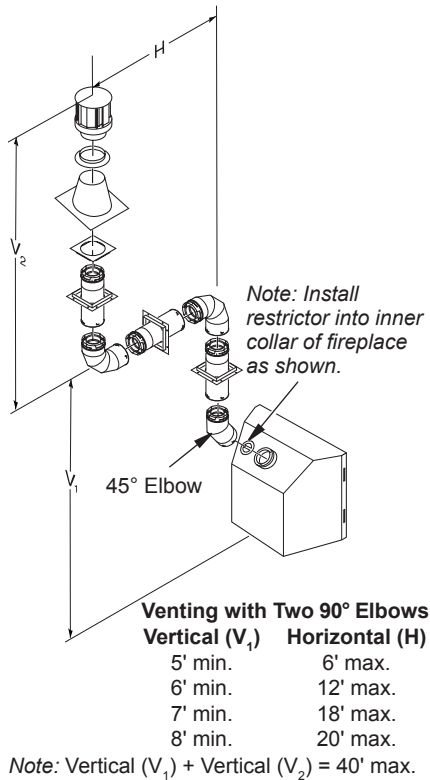

**Figure 23 - Vertical Venting Configuration Using Two 90° Elbows (Vertical Round High Wind Termination Shown)**

# VENTING INSTALLATION

Continued

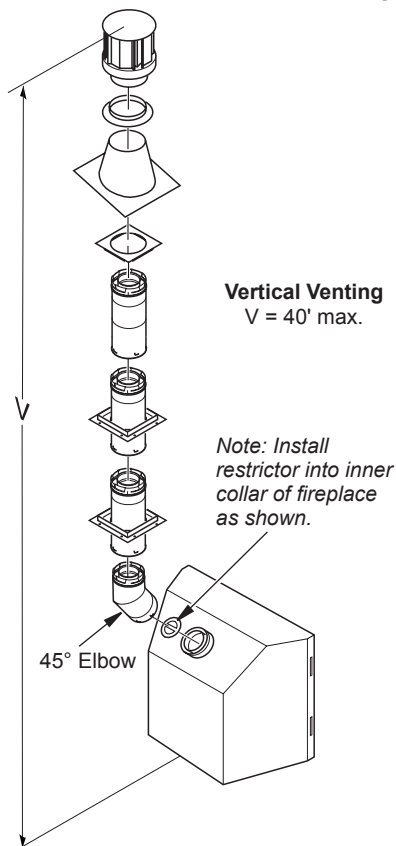

**Figure 24 - Vertical Venting Configuration With No Horizontal Run (Vertical Round High Wind Termination Shown)**

## HIGH ALTITUDE INSTALLATION

Your FMI PRODUCTS, LLC direct-vent fireplace has been tested and approved for elevations from 0-2000 feet (USA).

Fireplaces for High Altitude (models ending in -HA) are for installation above 4000 feet only. These fireplaces are equipped with parts specific for higher altitudes.

When installing a non-high altitude fireplace at an elevation above 2000 feet (in the USA), you may need to decrease the input rating by changing the existing burner orifice to a smaller size. Reduce input 4% for each 1000 feet above sea level. Check with your local gas company for proper orifice size identification.

**IMPORTANT:** For horizontal installations above 2,000 feet, it is recommended that a 12" extension pipe be added before

starter elbow (see Figure 25) and a round horizontal termination be used.

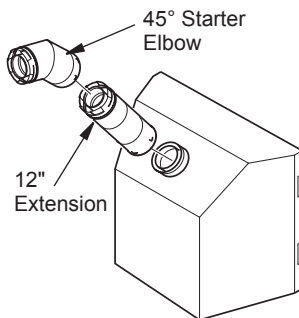

**Figure 25 - Recommended 12" Extension for High Altitude Installation**

## PARTS LIST FOR VENTING KITS AND COMPONENTS

FMI PRODUCTS, LLC (5" / 8") Pipe & Vent Kits

Number	Description
P58-6	6" Section Double Wall Pipe, Galvanized
P58-12	12" Section Double Wall Pipe, Galvanized
P58-24	24" Section Double Wall Pipe, Galvanized
P58-36	36" Section Double Wall Pipe, Galvanized
P58-48	48" Section Double Wall Pipe, Galvanized
PA58-712	Adjustable 7"-12" Section Double Wall Pipe, Galvanized
E58-45	45° Elbow, Galvanized
E58-90	90° Elbow, Galvanized
VKG-58	Ground Floor Vent Kit, Galvanized (Includes: 45° Elbow, 7"-12" Adjustable Pipe, Wall Firestop, Horizontal Square Termination, 16 Screws)
VKB-58	Basement Vent Kit, Galvanized (Includes: 45° Elbow, 7"-12" Adjustable Pipe, Wall Firestop, Horizontal Square Termination, 4' Pipe, 90° Elbow, 20 Screws)
VKS-58	Snorkel Vent Kit, Galvanized (Includes: 45° Elbow, 7"-12" Adjustable Pipe, Wall Firestop, 36" Snorkel Termination, 4' Pipe, 1" Pipe, 90° Elbow, 26 Screws)
VKR-58	Roof Vent Kit, Galvanized (Includes: 45° Elbow, 7"-12" Adjustable Pipe, Flue Restrictor, Vertical High Wind Termination, 2' Pipe, 4' Pipe, Wall Firestop, Storm Collar, Roof Flashing [0/12 - 6/12], 26 Screws)

# VENTING INSTALLATION

*Continued*

<u>Number</u>	<u>Description</u>	<u>Number</u>	<u>Description</u>
VKC-58	Corner Vent Kit, Galvanized (Includes 45° Elbow, 7"-12" Adjustable Pipe, Wall Firestop, Horizontal Termination, 6" Pipe, 90° Elbow, 18 Screws)	ST-58-14	14" Snorkel Termination, Galvanized
HHTK-58	High Wind Round Horizontal Termination Kit (Includes Round Termination, Wall Firestop, 45° Elbow)	ST-58-36	36" Snorkel Termination, Galvanized
HHT-58	High Wind Round Termination Kit, Galvanized	SC-58	Storm Collar, Galvanized
HTK-58	Horizontal Round Termination Kit (Includes Round Termination, Wall Firestop, 45° Elbow)	WF-58	Wall Firestop, Galvanized
HT-58	Horizontal Round Termination, Galvanized	RF-58-6	Roof Flashing - 0 to 6/12 Pitch, Galvanized
HTS-58	Horizontal Square Termination, Galvanized	RF-58-12	Roof Flashing - 6/12 to 12/12 Pitch, Galvanized
HTKS-58	Horizontal Square Termination Kit (Includes: Square Termination, Wall Firestop, 45° Elbow)	VR-58	Vertical Restrictor, Galvanized
HTS-58	Horizontal Square Termination, Galvanized	S-58	Vinyl Siding Standoff, Galvanized
VT-58	Vertical Round Termination, Galvanized	WS-58	Wall Strap
		CS-58	Cathedral Ceiling Support
		FP-58	Firestop Plate
		SF-58	Stucco Flashing - For use with HTS-58
		RF-58	Flat Roof Flashing
		PF58-927	Flex Pipe Section 9" to 24"
		PF58-1236	Flex Pipe Section 12" to 36"
		PF58-1854	Flex Pipe Section 18" to 54"
		VKF58-927	Flex Kit (Includes Flex Pipe Wall Section 9" to 27", Firestop and Horizontal Square Termination)

## FIREPLACE INSTALLATION

### CHECK GAS TYPE

Use proper gas type for fireplace unit you are installing. If your gas supply is not correct, do not install fireplace. See retailer where you purchased fireplace for proper fireplace according to your gas type or to purchase gas conversion kit (see *Accessories*, page 42).

### INSTALLING OPTIONAL BLOWER ACCESSORY

**NOTICE:** If installing blower in an existing fireplace with gas connections, shut off gas supply and disconnect fireplace from gas supply. Contact a qualified service person to do this.

**WARNING:** If there is a duplex electrical outlet installed in the right side of the bottom of the fireplace base area, be sure that the electrical power to the outlet is turned off before proceeding with blower installation. Failure to do this may result in serious injury.

### Model BK Installation

Follow all instructions provided in blower accessory kit.

1. Attach power cord to blower motor by firmly pushing two female terminals at end of power cord onto two spade terminals on blower motor (see Figure 26).
2. Attach green ground wire from power cord to blower housing using screw provided (see Figure 26). Tighten screws securely.
3. Place blower against lower rear wall of firebox outer wrapper with exhaust port directed upward. Blower will fit inside back opening and be held in position against back wall by magnets (see Figure 26).

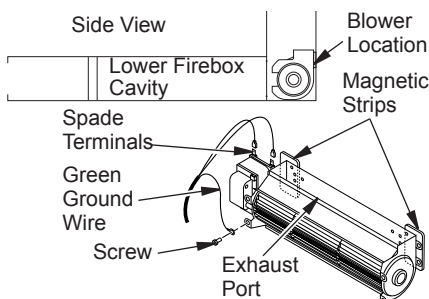
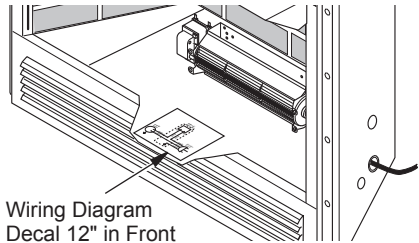

**Figure 26 - Blower Model BK**

# FIREPLACE INSTALLATION

*Continued*

4. Be certain that all wire terminals are securely attached to terminals on blower motor and that screw retaining green ground wire is tight.
5. Mount speed control box to switch bracket by placing plastic control shaft forward through opening in switch bracket (see Figure 27).
6. While supporting speed control, secure control shaft with lock nut by pushing and turning lock nut with pliers clockwise until it is tight against front panel. Place provided control knob on shaft.
7. Turn on power to duplex outlet if previously turned off per warning in column 1, page 19.
8. Plug in blower power cord.
  - a. If your firebox is installed as a free-standing unit with an accessory mantel, determine whether power cord will exit left side or right side of firebox. Route power cord through exit hole and plug power cord into a wall receptacle near firebox.
  - b. If your firebox installation is recessed and/or prewired, plug power cord into duplex outlet provided. Refer to your firebox owner's manual for instructions on wiring duplex outlet.
9. Check to make sure that power cord is completely clear of blower wheel and that there are no other foreign objects in blower wheel. Turn blower on and check for operation. Turn blower off by turning knob fully counterclockwise before continuing.
10. Peel off backing paper and stick supplied wiring diagram decal on firebox bottom approximately 12" in front of blower (see Figure 28).



Wiring Diagram Decal 12" in Front of Blower

**Figure 28 - Location of Wiring Diagram Decal (Model May Vary From Illustration)**

## Model BKT Installation

**Note:** The BKT blower is for application into direct-vent models only. When installing the BKT thermostatically-controlled blower, you must first secure the wiring connections from the thermal switch to the blower (if it has not already been factory installed).

1. Attach green ground wire from power cord to blower housing using screw provided (see Figure 29, page 21) Tighten screws securely with a Phillips screwdriver.
2. Connect wire harness and power cord terminals. Connect the jumper wire to the blower motor terminal to the terminal of the thermal switch. Connect one wire of the thermal switch and one wire to the other remaining blower motor terminal.

**Note:** The power cord outer insulation sleeve may have to be stripped slightly to allow enough wire length to reach and make all connections. DO NOT trim excessive length away. Just enable enough to make all connections securely.

**CAUTION: Never touch blower wheel while in operation.**

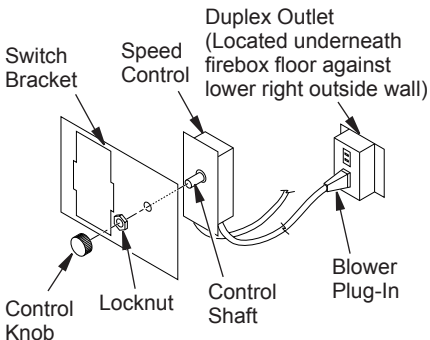
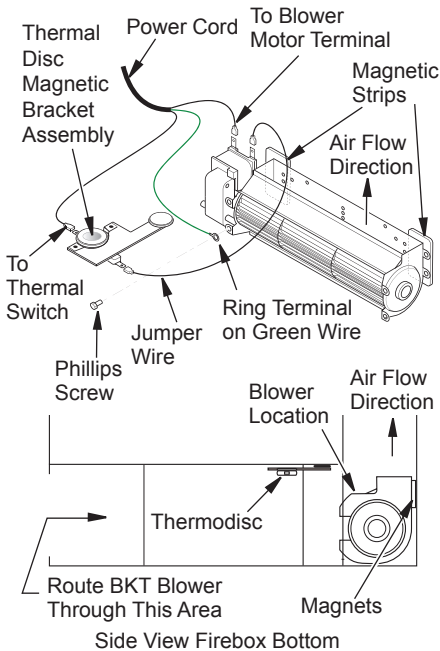

**Figure 27 - Attaching Speed Control to Firebox**

# FIREPLACE INSTALLATION

*Continued*

3. Place the blower against the lower rear wall of the firebox outer wrapper with the exhaust port directed upward. Attach Thermal disc magnetic bracket to the bottom of the firebox sub-floor. The thermo-disc must be oriented near the fireplace bottom as shown in Figure 29, in order to sense temperature and properly operate. The blower will be held in position against the back wall by the magnets incorporated onto the blower housing (see Figure 29).
4. Be certain that all wire terminals are securely attached to terminals on blower motor and that the screw retaining the green ground wire is tight.
5. Mount speed control box against mounting plate provided in lower fireplace cavity by placing plastic control shaft forward through round hole (see Figure 27, page 20).
6. While supporting speed control, secure control shaft with lock nut by pushing and turning lock nut with pliers clockwise until it is tight against mounting plate. Place control knob provided on shaft (see Figure 27, page 20).
7. Check to make sure that power cord is completely clear of blower wheel and that there are no other foreign objects in blower wheel. Also double check all wire leads and make sure wire routing is not pinched or in a precarious position. Correct accordingly.
8. Turn on power to duplex outlet if previously turned off per warning in column 1, page 19.
9. Plug in blower power cord to duplex outlet.
10. Blower will only run when speed control knob is in the ON position and thermal switch senses temperature after fireplace begins to heat up. Blower speed can be adjusted by rotating control knob. To turn off, turn knob fully counterclockwise until it clicks off. If blower is ON and has been running with fireplace operating, blower will continue to run for a short time after fireplace has been turned off. As thermal switch cools down, blower shuts down automatically.
11. Peel off the backing paper and stick the supplied wiring diagram decal on the firebox bottom approximately 12" in front of the blower (see Figure 28, page 19).



**Figure 29 - Blower Model BKT**

## Blower Wiring Diagram

**⚠ CAUTION: Label all wires prior to disconnection when servicing controls. Wiring errors can cause improper and dangerous operation. Verify proper operation after servicing.**

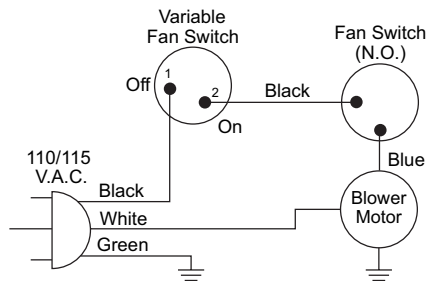

**Figure 30 - Blower Wiring Diagram for Thermostat-Controlled Models**

# FIREPLACE INSTALLATION

*Continued*

## INSTALLING GAS PIPING TO FIREPLACE LOCATION

**⚠ WARNING:** A qualified service person must connect fireplace to gas supply. Follow all local codes.

**⚠ CAUTION:** For propane/LP units, never connect fireplace directly to the propane/LP supply. This fireplace requires an external regulator (not supplied). Install the external regulator between the fireplace and propane/LP supply.

**⚠ WARNING:** For natural gas, never connect fireplace to private (non-utility) gas wells. This gas is commonly known as wellhead gas.

### Installation Items Needed

Before installing fireplace, make sure you have the items listed below.

- external regulator (supplied by installer)
- piping (check local codes)
- sealant (resistant to propane/LP gas)
- equipment shutoff valve \*
- test gauge connection \*
- sediment trap
- tee joint
- pipe wrench
- approved flexible gas line with gas connector (if allowed by local codes)

\* An equipment shutoff valve with 1/8" NPT tap is an acceptable alternative to test gauge connection. Purchase the equipment shutoff valve from your retailer.

For propane/LP connection only, the installer must supply an external regulator. The external regulator will reduce incoming gas pressure. You must reduce incoming gas pressure to between 11" and 14" of water. If you do not reduce incoming gas pressure,

fireplace regulator damage could occur. Install external regulator with the vent pointing down as shown in Figure 31. Pointing the vent down protects it from freezing rain or sleet.

**⚠ CAUTION:** Use only new, black iron or steel pipe. Internally-tinned copper tubing may be used in certain areas. Check your local codes. Use pipe of 1/2" inside diameter or greater to allow proper gas volume to fireplace. If pipe is too small, undue loss of volume will occur.

Installation must include an equipment shutoff valve, union and plugged 1/8" NPT tap. Locate NPT tap within reach for test gauge hook up. NPT tap must be upstream from fireplace (see Figure 32, page 23).

**IMPORTANT:** Install main gas valve (equipment shutoff valve) in an accessible location. The main gas valve is for turning on or shutting off the gas to the appliance.

Check your building codes for any special requirements for locating equipment shutoff valve to fireplaces.

Apply pipe joint sealant lightly to male NPT threads. This will prevent excess sealant from going into pipe. Excess sealant in pipe could result in clogged fireplace valves.

**⚠ WARNING:** Use pipe joint sealant that is resistant to liquid petroleum (LP) gas.

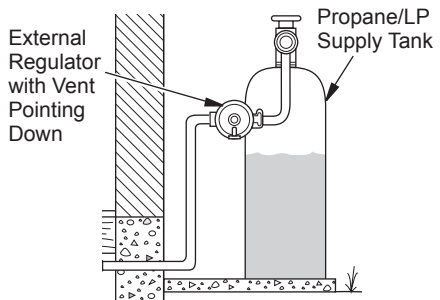
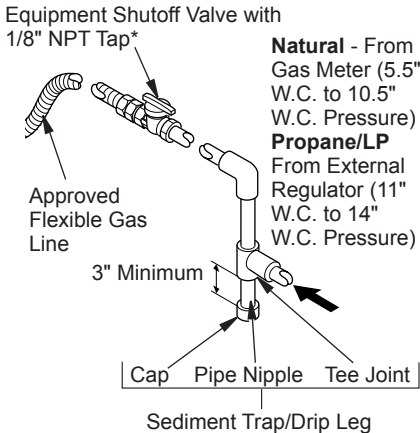

**Figure 31 - External Regulator with Vent Pointing Down (Propane/LP Only)**

# FIREPLACE INSTALLATION

## Continued

We recommend that you install a sediment trap/drip leg in supply line as shown in Figure 32. Locate sediment trap/drip leg where it is within reach for cleaning. Install in piping system between fuel supply and fireplace. Locate sediment trap/drip leg where trapped matter is not likely to freeze. A sediment trap traps moisture and contaminants. This keeps them from going into fireplace gas controls. If sediment trap/drip leg is not installed or is installed wrong, fireplace may not run properly.



**Figure 32 - Gas Connection**

\* The equipment shutoff valve may be supplied with the appliance or you can purchase it from your retailer.

## CONNECTING FIREPLACE TO GAS SUPPLY

### Installation Items Needed

- 5/16" hex socket wrench or nut-driver
  - sealant (resistant to propane/LP gas, not provided)
1. Open lower louver door panel by gently pulling forward.
  2. Route flexible gas line (provided by installer) from equipment shutoff valve to fireplace. Route flexible gas supply line through one of the access holes on side of fireplace.
  3. Attach flexible gas line from gas supply to control valve (see Figure 33).
  4. Check all gas connections for leaks. See [Checking Gas Connections](#).

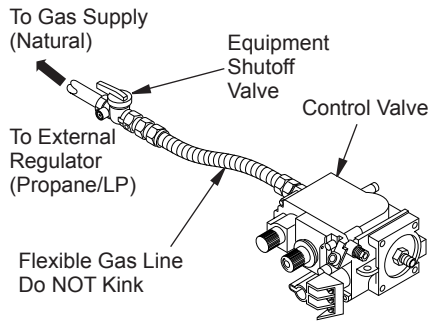

**Figure 33 - Connecting Flexible Gas Line to Millivolt Valve**

## CHECKING GAS CONNECTIONS

**WARNING:** Test all gas piping and connections, internal and external to unit, for leaks after installing or servicing. Correct all leaks at once.

**WARNING:** Never use an open flame to check for a leak. Apply noncorrosive leak detection fluid to all joints. Bubbles forming show a leak. Correct all leaks at once.

## PRESSURE TESTING GAS SUPPLY PIPING SYSTEM

Test Pressures In Excess Of 1/2 PSIG (3.5 kPa)

1. Disconnect fireplace and its individual equipment shutoff valve from gas supply piping system. Pressures in excess of 1/2 psig (3.5 kPa) will damage fireplace gas regulator.
2. Cap off open end of gas pipe where equipment shutoff valve was connected.
3. Pressurize supply piping system by either opening propane/LP supply tank valve for propane/LP gas fireplace or opening main gas valve located on or near gas meter for natural gas fireplace or using compressed air.
4. Check all joints of gas supply piping system. Apply noncorrosive leak detection fluid to all joints. Bubbles forming show a leak. Correct all leaks at once.
5. Reconnect fireplace and equipment shutoff valve to gas supply. Check reconnected fittings for leaks.



## FIREPLACE INSTALLATION

*Continued*

### Test Pressures Equal To or Less Than 1/2 PSIG (3.5 kPa)

1. Close equipment shutoff valve (see Figure 34).
2. Pressurize supply piping system by either opening propane/LP supply tank valve for propane/LP gas fireplace or opening main gas valve located on or near gas meter for natural gas fireplace or using compressed air.
3. Check all joints from propane/LP supply tank for propane/LP or gas meter for natural gas to equipment shutoff valve (see Figure 35 or Figure 36). Apply non-corrosive leak detection fluid to all joints. Bubbles forming show a leak. Correct all leaks at once.

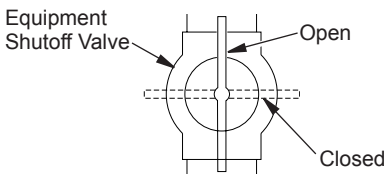

**Figure 34 - Equipment Shutoff Valve**

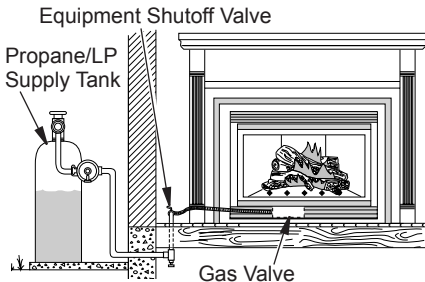

**Figure 35 - Checking Gas Joints for Propane/LP Gas Fireplace**

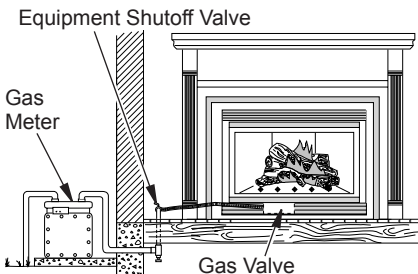

**Figure 36 - Checking Gas Joints for Natural Gas Fireplace**

### PRESSURE TESTING FIREPLACE GAS CONNECTIONS

1. Open equipment shutoff valve (see Figure 34).
2. Open main gas valve located on or near gas meter for natural gas or open supply tank valve for propane/LP gas.
3. Make sure control knob of fireplace is in the OFF position.
4. Check all joints from equipment shutoff valve to gas valve (see Figure 35 or Figure 36). Apply noncorrosive leak detection fluid to all joints. Bubbles forming show a leak. Correct all leaks at once.
5. Light fireplace (see *Operation*, page 28). Check all other internal joints for leaks.
6. Turn off fireplace (see *To Turn Off Gas to Appliance*, page 29).

### INSTALLING OPTIONAL WALL MOUNT SWITCH - GWMS2

1. Connect one terminal of 25 ft. wire for wall switch to TPTH terminal on valve. Connect remaining wire terminal to TH terminal on valve. Make sure that wire terminals are in positions on unit as pictured in Figure 37. If wires are not connected as shown the switch will not work.
2. Route 25 ft. wire through openings provided on sides of burner system to a convenient location to mount your switch.
3. Connect one bare wire end to each of the terminals of the GWMS2 wall switch.
4. Install wall switch and cover in wall.

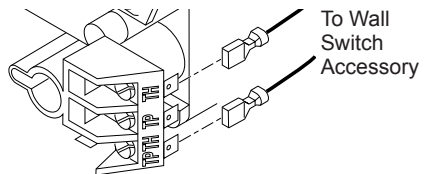

**Figure 37 - Connecting Wall Switch to Control Valve**

### INSTALLING OPTIONAL WIRELESS HAND-HELD REMOTE CONTROL MRC SERIES

**NOTICE: Use only alkaline batteries (not included).**

#### Installing Remote Receiver

1. Open bottom louver (V)(TC32 series) or remove screen door assembly (V)(TC32 series) and locate switch bracket on the right.



# FIREPLACE INSTALLATION

Continued

2. Remote receiver can be placed in the hole on the switch bracket or place on the floor underneath the firebox. See remote instructions for further information.
3. Attach terminal wires to battery.
4. Connect wires from receiver to TH and TPTH to control valve (see Figure 38).

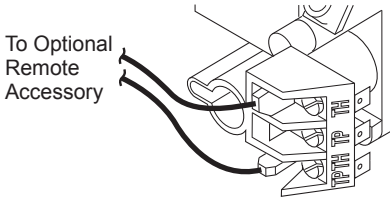

Figure 38 - Control Valve Terminals

## Removing Louver Panels

Remove top and bottom louver panels by simultaneously pulling both top end spring latches towards center of appliance until they are disengaged from locating holes (see Figure 39). Repeat for bottom spring latches and pull louvers outward. To install or replace items removed, simply reverse procedures above.

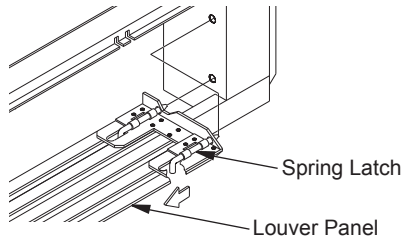

Figure 39 - Removing Louver Panel

## REMOVING/REPLACING GLASS DOOR

**WARNING**

HOT GLASS WILL CAUSE BURNS.  
DO NOT TOUCH GLASS UNTIL COOLED.  
NEVER ALLOW CHILDREN TO TOUCH GLASS.



**CAUTION:** Do not operate this fireplace with a broken glass door panel or without the glass door panel securely in place. For replacement part information see *Replacement Parts*, page 33.

**CAUTION:** Wear gloves and safety glasses while handling or removing broken glass. Do not remove if glass is hot. Keep children and pets away from glass.

**WARNING:** If fireplace has been running, turn off and unplug fireplace. Let cool before removing glass door or louvers.

## Removing Screen Door Assembly (TC32 Series)

Push screen door assembly in toward the bottom left and right sides until the magnetic door latch pops the screen door out. Hold the screen door assembly at the bottom and swing the door up to disengage the tabs on the top of the door from inside the slots underneath the upper face.

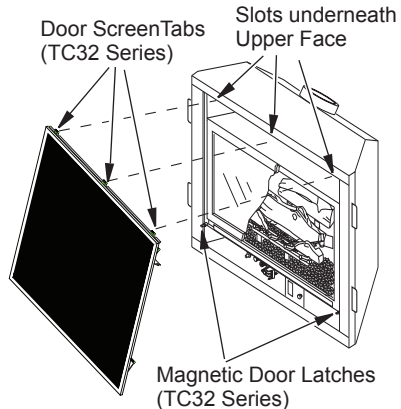

Figure 40 - Removing/Replacing Screen Door Assembly (TC32 Series)

## Replacing Screen Door Assembly (TC32 Series)

Push magnetic door latch out to the open position. Position screen door tabs with slot openings in upper face frame. Swing door screen assembly in towards the bottom face,

## FIREPLACE INSTALLATION

*Continued*

Press in on the bottom of door screen until magnetic door latch is pushed in.

### Removing Glass Door

If replacement of glass is necessary, the entire assembly, glass and frame, must be replaced. If glass is broken, wear gloves and tape remaining fragments onto frame.

1. Remove screen/rod assembly from firebox, push rod either left or right and then down and forward. Set assembly aside.
2. Lift up on latches to unlock. There are two on top of firebox and two below firebox that hold glass door in place (see Figure 41).
3. While holding glass door to prevent it from falling and causing injury, remove the five screws from hinge located on left side of door frame assembly (see Figure 42).

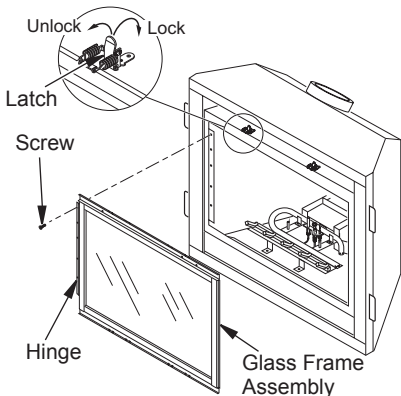

**Figure 41 - Removing/Replacing Glass Door**

4. Remount new frame at hinge with five new screws before closing door. This will ensure seating of gasket.
5. Close glass door frame. Lock latches by placing bar under tab on door and pushing down and back on latch (see Figure 41).
6. Replace screen/rod assembly by reversing step 1.
7. Replace louvers by reversing procedure under *Removing Louver Panels*, page 24 for T32N-A Series.
8. Replace screen door assembly, see removing screen door assembly, page 24, (for TC32 series).

### Cleaning Glass Door

See *Cleaning and Maintenance* on page 30.

## INSTALLING OPTIONAL BRICK LINER MODEL BL32D

**⚠ WARNING:** If fireplace has been running, turn off and unplug fireplace. Let cool before installing brick liner.

This brick liner kit is optional. You may purchase brick liner from your local retailer or see *Replacement Parts*, page 33.

**⚠ CAUTION:** Always handle brick panels with two hands. Do not force brick panels into place. Excessive force will break brick panels.

1. Remove top and bottom louvers to allow access to door latches.
2. Unlock door latches and open glass door. See steps 1 and 2 of *Removing/Replacing Glass Door*, page 25.
3. If installing brick liner in new fireplace, go to step 4. If installing brick liner in an existing fireplace, carefully remove logs, lava rock and ember material.
4. Remove three screws from deflector shield on the inside top of firebox. Set shield and screws aside.
5. Install rear brick panel first. Rest bottom edge of panel on back edge of grate (see Figure 42).
6. Install left side brick panel by sliding it between grate and side of firebox (see Figure 42).
7. Install right brick panel using the same method described in step 5 for left brick panel.

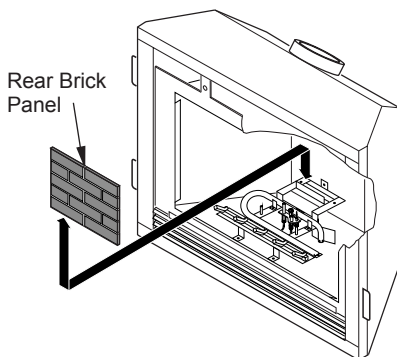
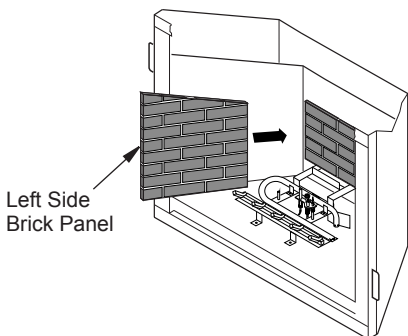

**Figure 42 - Installing Rear Brick Panel**

## FIREPLACE INSTALLATION

### Continued

8. Replace deflector shield using screws removed in step 4.
9. Follow instructions below to install logs, lava rock and ember material.
10. Close glass door, lock latches on top and bottom of door and replace screen (see steps 5 and 6 of *Removing Glass Door*, page 26).
11. Close top and bottom louvers.



**Figure 43 - Installing Side Brick Panels**

### INSTALLING LOGS, LAVA ROCK AND GLOWING EMBERS

It is very important to install these logs exactly as instructed. Do not modify logs. Only use logs supplied with fireplace.

Open louvers, remove screen, unlock door latches and open glass door. See steps 1 and 2 of *Removing Glass Door*, page 26. Install logs according to instructions for fireplace model numbers.

1. Find and place log #1 (rear log). The log has a flat bottom with a slit cut into it to sit over the grate flap, (see Figure 44).

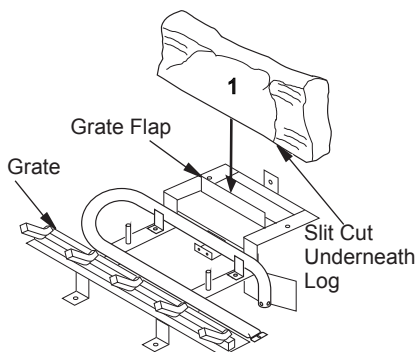

**Figure 44 - Installing Log No. 1**

2. Rest log #2 (front log) on pins on front part of grate (see Figure 45).

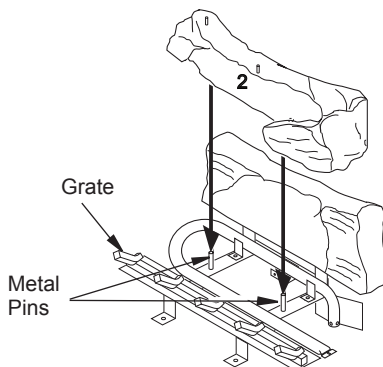

**Figure 45 - Installing Log No. 2**

3. Place log #3 (crossover log) onto front log. Make sure it is seated properly on surface of rear log and pin on front log as shown in Figure 46.

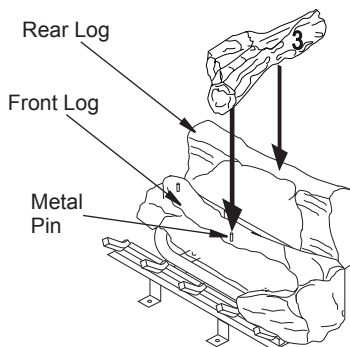

**Figure 46 - Installing Log No. 3**

4. Place log #4 (right log) onto the landing on right side of front log as shown in Figure 47.

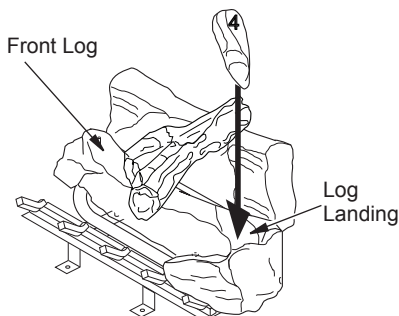
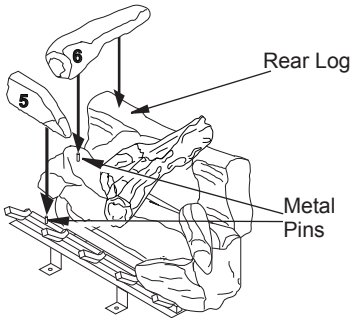

**Figure 47 - Installing Log No. 4**

# FIREPLACE INSTALLATION

*Continued*

- Place log #5 (base log) onto front left part of grate making sure log fits over metal pin of grate. See Figure 48.
- Place log #6 (left log) onto pin on left side of front log, the rear part of log rests over the log no. 1 (See Figure 48).

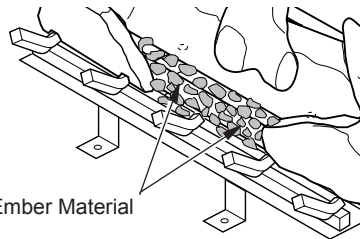

**Figure 48 - Installing Logs No. 5 and No. 6**

- Place lava rock along sides and front of firebox bottom in areas that are visible only. It is not necessary to use all of the lava rock provided.

**NOTICE: Do not put lava rock on burner or under burner. Placing lava rock on burner will cause performance problems.**

- Pull ember material apart into pieces no larger than a dime. Place these pieces loosely and sparingly directly onto exposed section of front burner and along space between burner and grate prongs (see Figure 49). This will create the glowing ember appearance as the flame touches the ember material. Do not block air slots by using too much ember material in one area. Place small pieces of ember material to cover pilot ports. It is not necessary to use all of the ember material provided.



**Figure 49 - Placing Ember Material on Burner**

- Close glass door, lock door latches, replace screen and close louvers (see steps 5 and 7 of *Removing Glass Door*, page 26).

## OPERATION

**FOR YOUR SAFETY  
READ BEFORE LIGHTING**

**WARNING:** If you do not follow these instructions exactly, a fire or explosion may result causing property damage, personal injury or loss of life.

- This appliance is equipped with an ignition device which automatically lights the pilot. Do not try to light the pilot by hand.
- BEFORE LIGHTING** smell all around the appliance area for gas. Be sure to smell next to the floor because some gas is heavier than air and will settle on the floor.

### WHAT TO DO IF YOU SMELL GAS

- Do not try to light any appliance.
  - Do not touch any electric switch.
  - Do not use any phone in your building.
  - Immediately call your gas supplier from a neighbor's phone. Follow the gas supplier's instructions.
  - If you cannot reach your gas supplier, call the fire department.
- Use only your hand to push in or turn the gas control knob. Never use tools. If the knob will not push in or turn by hand, don't try to repair it, call a qualified service technician. Force or attempted repair may result in a fire or explosion.
  - Do not use this appliance if any part has been under water. Immediately call a qualified service technician to inspect the appliance and to replace any part of the control system and any gas control which has been under water.

# OPERATION

Continued

## LIGHTING INSTRUCTIONS

1. STOP! Read the safety information on page 28.
2. Open lower louver panel.
3. Turn off all electric power to fireplace.
4. Push in gas control knob slightly and turn clockwise ↷ to OFF.
5. Wait five (5) minutes to clear out any gas. Then smell for gas, including near the floor. If you smell gas, STOP! Follow "B" in the safety information on page 28. If you don't smell gas, go to the next step.
6. The pilot is located by the main burner and should not require accessing for lighting.
7. Turn gas control knob counterclockwise ↶ to PILOT (see Figure 50).
8. Push in gas control knob all the way and hold. Immediately light the pilot by repeatedly pressing the piezo spark ignitor until a flame appears. Continue to hold for about 1 minute after pilot is lit. Release gas control knob and it will pop back. Pilot should remain lit. If it goes out, repeat steps 4 through 8.
  - If gas control knob does not pop up when released, stop and immediately call your service technician or gas supplier.
  - If pilot will not stay lit after several tries, turn gas control knob to OFF and call your service technician or gas supplier.
9. Turn on all electric power to fireplace.
10. Turn gas control knob counterclockwise ↶ to ON.
11. This valve is equipped with a HI/LO feature. Set fireplace input as desired.
12. To leave pilot lit and shut off burners only, turn control knob clockwise ↷ to the PILOT position or set selector switch in the OFF position.
13. Close lower louver panel.

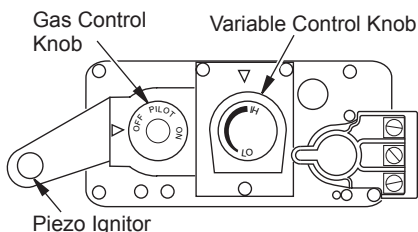

Figure 50 - Control Valve

## TO TURN OFF GAS TO APPLIANCE

1. Open lower louver panel.
2. Set selector switch in the OFF position to prevent draining battery.
3. Turn off all electrical power to appliance if service is to be performed.
4. Push in gas control knob slightly and turn clockwise ↷ to OFF.
5. Close lower louver panel.

## MANUAL LIGHTING PROCEDURE

1. Remove glass door (see [Removing/Replacing Glass Door](#), page 25).
2. Follow steps 1 through 8 under [Lighting Instructions](#).
3. Press gas control knob and light pilot with match.
4. Keep gas control knob pressed in for 30 seconds after lighting pilot. After 30 seconds, release gas control knob. Follow steps 10 through 13 under [Lighting Instructions](#).
5. Replace glass door (see [Removing/Replacing Glass Door](#), page 25).

## OPTIONAL HAND-HELD REMOTE OPERATION

*Note: All remote control accessories must be purchased separately (see [Accessories](#), page 42). Follow instructions included with the remote control.*

**NOTICE: You must light the pilot before using the hand-held remote control unit. See [Lighting Instructions](#).**

After lighting, let pilot flame burn for about one minute. Turn control knob to ON position. Adjust flame adjustment knob anywhere between HI and LO. Slide selector switch to the REMOTE position (see Figure 51, page 30). *Note: The burner may light if hand-held remote was on when selector switch was last turned off. You can now turn the burner on and off with the hand-held remote control unit.* **IMPORTANT:** Do not leave selector switch in the REMOTE or ON position when the pilot is not lit. This will drain the battery.

## OPERATION

*Continued*

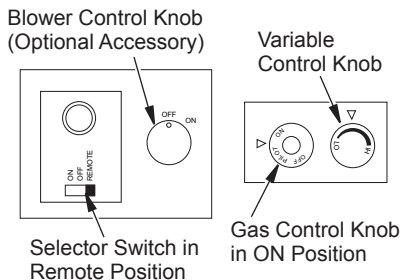

**Figure 51 - Setting Selector Switch, Gas Control Knob and Variable Control Knob for Remote Operation**

### OPERATING OPTIONAL BLOWER ACCESSORY

Locate blower controls by opening lower louver panel on fireplace. Blower controls are located on the right side of switch bracket to the left just inside louver panel.

The BK manual blower and BKT thermostatically-controlled blower have an ON setting and an OFF setting. Blower will only run when the switch is in the ON position. In the OFF position, blower will not operate.

**Note for BKT Only:** If you are using BKT blower with optional thermostat (wall mounted or remote control) for the fireplace, your fireplace and blower will not turn on and off at the same time. Fireplace may run for several minutes before blower turns on. After fireplace modulates to the pilot position, blower will continue to run. Blower will shut off after firebox temperature decreases.

The blower helps distribute heated air from the fireplace. Periodically check louvers of firebox and remove any dust, dirt or other obstructions that will hinder the flow of air.

## INSPECTING BURNERS

Check pilot flame pattern and burner flame patterns often.

### PILOT ASSEMBLY

The pilot assembly is factory preset for the proper flame height. Alterations may have occurred during shipping and handling. Call a qualified service person to readjust the pilot if necessary.

The height of the thermopile must be  $\frac{3}{8}$ " to  $\frac{1}{2}$ " above pilot flame as shown in Figure 52. The thermocouple must be at a height of about  $\frac{1}{8}$ " above pilot flame. The flame from pilot burner must extend beyond both the thermocouple and thermopile.

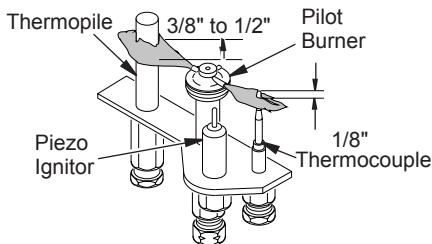

**Figure 52 - Pilot Assembly**

If your pilot assembly does not meet these requirements:

- turn fireplace off (see [To Turn Off Gas to Appliance](#), page 29)
- see [Troubleshooting](#), page 34

### BURNER FLAME PATTERN

Burner flames will be steady, not lifting or floating. Flame patterns will be different from unit to unit and will vary depending on installation type and weather conditions.

If the vent configuration is installed incorrectly, flames will lift or "ghost". This can be dangerous. Inspect flames after installation to ensure proper installation and performance.

Figure 53 shows a typical flame pattern.

If burner flame pattern differs from that described:

- turn fireplace off (see [To Turn Off Gas to Appliance](#), page 29)
- see [Troubleshooting](#), page 34

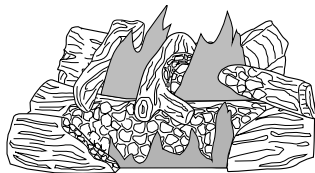

**Figure 53 - Typical Flame Pattern**

## CLEANING AND MAINTENANCE

**⚠ WARNING:** Turn off fireplace and let cool before cleaning.

**⚠ CAUTION:** You must keep control areas, burners and circulating air passageways of fireplace clean. Inspect these areas of fireplace before each use. Have fireplace inspected yearly by a qualified service person. Fireplace may need more frequent cleaning due to excessive lint from carpeting, bedding material, pet hair, etc.

**⚠ WARNING:** Only parts supplied by the manufacturer should be used when replacing broken or damaged glass door panel (see *Replacement Parts*, page 33). This glass door panel is a complete unit. No substitute materials may be used.

**⚠ CAUTION:** Wear gloves and safety glasses while handling or removing broken glass. Do not remove if glass is hot. Keep children and pets away from glass.

### GLASS DOOR

**⚠ WARNING:** Handle glass door panel with care. Do not strike, slam or otherwise abuse glass. Do not operate fireplace with the glass door unlatched, removed, cracked or broken.

**⚠ WARNING:** Do not use abrasive cleaners as this may damage glass. Use a nonabrasive household glass cleaner to clean glass. Do not clean glass when hot.

If glass has been broken, carefully remove glass door (see *Removing/Replacing Glass Door*, page 25). Vacuum all glass pieces with a shop vac.

**⚠ CAUTION:** Do not vacuum if pieces are hot.

Use only the tempered glass door replacement intended for this fireplace (see *Replacement Parts*, page 33 for detail on ordering). No substitutions may be made. See *Removing/Replacing Glass Door*, page 25 for instructions for replacing glass door.

**⚠ WARNING:** Do not operate fireplace with the glass door unlatched, removed, cracked or broken.

Glass must be cleaned periodically. During start up it is normal for condensation to form on the inside of glass causing lint, dust and other airborne particles to cling to glass surface. During initial start up a slight film may form on glass due to paint curing. Glass should be cleaned several times with a non-ammonia, nonabrasive household cleaner and warm water after the first two weeks of operation. Afterwards, clean glass two or three times during each heating season, depending on the usage and circumstances present. Refer to *Removing/Replacing Glass Door* on page 25 of this manual when removing glass door for cleaning.



# CLEANING AND MAINTENANCE

*Continued*

## PILOT AND BURNERS

- Remove ember material before cleaning burners and replace when cleaning is complete.
- Burner and controls should be cleaned with compressed air to remove dust, dirt or lint.
- Use a vacuum cleaner or small, soft bristled brush to remove excess dust, dirt or lint.

## LOGS

- If you remove logs for cleaning, refer to *Installing Logs, Lava Rock and Glowing Embers*, page 27, to properly replace logs.
- Use a vacuum cleaner to remove any carbon buildup on logs.
- Replace log(s) if broken. See *Replacement Parts* on page 33.
- Replace ember material periodically as needed. See *Replacement Parts* on page 33.

## VENTING SYSTEM

Conduct annual inspection of venting system following these guidelines:

1. Check areas of venting system that are exposed to the weather for corrosion (rust spots or streaks and, in extreme cases, holes). Have these items replaced immediately by a qualified service person.
2. Remove the vent cap and shine a flashlight into the vent. Remove any foreign material.
3. Check for evidence of excessive condensation. Continuous condensation can cause corrosion of caps, pipes and fittings and can be caused by having excessive lateral runs, too many elbows or exterior portions of the system being exposed to cold weather.
4. Inspect joints to verify that no pipe section or fitting has been disturbed and loosened. Check mechanical supports such as wall straps for rigidity.



## REPLACEMENT PARTS

*Note: Use only original replacement parts. This will protect your warranty coverage for parts replaced under warranty.*

Contact authorized dealers of this product. If they can't supply original replacement part(s), call FMI PRODUCTS, LLC at 1-866-328-4537.

When calling, have ready:

- your name
- your address
- model and serial numbers of your fireplace
- how fireplace was malfunctioning
- purchase date

Usually, we will ask you to return the part to the factory.

## SERVICE HINTS

### When Gas Pressure Is Too Low

- pilot will not stay lit
- burners will have delayed ignition
- fireplace will not produce specified heat
- propane/LP gas supply might be low (propane/LP units only)

You may feel your gas pressure is too low. If so, contact your local gas supplier.

## TECHNICAL SERVICE

You may have further questions about installation, operation, or troubleshooting. If so, contact FMI PRODUCTS, LLC at 1-866-328-4537. When calling please have your model and serial numbers of your fireplace ready.

You can also visit FMI PRODUCTS, LLC's web site at [www.fmiproducts.com](http://www.fmiproducts.com).

## SPECIFICATIONS

### (V)T32N-A Series, (V)T32N-A-HA Series, (V)TC32N, (V)TC32N-HA, CGDV32NR and CTDV32NR-HA

- Rating: 12,000/18,000 Btu/Hr
- Type Gas: Natural Gas Only
- Ignition: Piezo
- Manifold Pressure:  
Models (V)T32N-A Series and CGDV32NR 3.5" W.C.  
Models (V)T32N-A-HA series and CTDV32NR-HA 3.8" W.C.

- Minimum Inlet Gas Pressure (W.C.): 5.5"
- Dimensions (H x W x D) (Firebox only. Does not include nailing flanges or standoffs): 32 1/4" x 34 1/2" x 16 5/8"
- Fireplace Weight\*: 80 lb
- Shipping Weight\*: 83 lb

\*For refractory lined models add 45 lb

### (V)T32P-A, (V)TC32P Series and CGDV32PR

- Rating: 11,000/17,000 Btu/Hr
- Type Gas: Propane/LP Gas Only
- Ignition: Piezo
- Manifold Pressure: 10" W.C.
- Minimum Inlet Gas Pressure (W.C.): 11"
- Dimensions (H x W x D) (Firebox only. Does not include nailing flanges or standoffs): 32 1/4" x 34 1/2" x 16 5/8"
- Fireplace Weight\*: 80 lb
- Shipping Weight\*: 83 lb

\*For refractory lined models add 45 lb

## TROUBLESHOOTING

**⚠ WARNING:** Turn off fireplace and let cool before servicing. Only a qualified service person should service and repair fireplace.

**⚠ CAUTION:** Never use a wire, needle or similar object to clean pilot. This can damage pilot unit.

*Note: All troubleshooting items are listed in order of operation.*

OBSERVED PROBLEM	POSSIBLE CAUSE	REMEDY
When ignitor button is pressed, there is no spark at pilot	<ol style="list-style-type: none"> <li>1. Ignitor electrode not connected to ignitor cable</li> <li>2. Ignitor cable pinched or wet</li> <li>3. Piezo ignitor nut is loose</li> <li>4. Broken ignitor cable</li> <li>5. Bad piezo ignitor</li> <li>6. Ignitor electrode broken</li> <li>7. Ignitor electrode positioned wrong</li> </ol>	<ol style="list-style-type: none"> <li>1. Reconnect ignitor cable</li> <li>2. Free ignitor cable if pinched by any metal or tubing. Keep ignitor cable dry</li> <li>3. Tighten nut holding piezo ignitor. Nut is located behind the mounting bracket</li> <li>4. Replace ignitor cable</li> <li>5. Replace piezo ignitor</li> <li>6. Replace pilot assembly</li> <li>7. Tighten electrode. Replace if necessary</li> </ol>
When ignitor button is pressed, there is spark at pilot but no ignition	<ol style="list-style-type: none"> <li>1. Gas supply turned off or equipment shutoff valve closed</li> <li>2. Gas control knob not in PILOT position</li> <li>3. Gas control knob not pressed in while in PILOT position</li> <li>4. Air in gas lines when installed</li> <li>5. Depleted gas supply (propane/LP models only)</li> <li>6. Pilot is clogged</li> <li>7. Gas regulator setting is not correct</li> </ol>	<ol style="list-style-type: none"> <li>1. Turn on gas supply or open equipment shutoff valve</li> <li>2. Turn gas control knob to PILOT position</li> <li>3. Press in gas control knob while in PILOT position</li> <li>4. Continue holding down control knob. Repeat igniting operation until air is removed</li> <li>5. Contact local propane/LP gas company</li> <li>6. Clean pilot (see <a href="#"><i>Cleaning and Maintenance</i></a>, page 31) or replace pilot assembly</li> <li>7. Replace gas regulator</li> </ol>

# TROUBLESHOOTING

*Continued*

OBSERVED PROBLEM	POSSIBLE CAUSE	REMEDY
Pilot lights but flame goes out when control knob is released	<ol style="list-style-type: none"> <li>1. Gas control knob not fully pressed in</li> <li>2. Gas control knob not pressed in long enough</li> <li>3. Equipment shutoff valve not fully open</li> <li>4. Pilot flame not touching thermocouple, which allows thermocouple to cool, causing pilot flame to go out. This problem could be caused by one or both of the following: A) Low gas pressure B) Dirty or partially clogged pilot</li> <li>5. Thermocouple connection loose at control valve</li> <li>6. Thermocouple damaged</li> <li>7. Control valve damaged</li> </ol>	<ol style="list-style-type: none"> <li>1. Press in gas control knob fully</li> <li>2. After pilot lights, keep gas control knob pressed in 30 seconds</li> <li>3. Fully open equipment shut-off valve</li> <li>4. A) Contact local natural or propane/LP gas company B) Clean pilot (see <i>Cleaning and Maintenance</i>, page 31) or replace pilot assembly</li> <li>5. Hand tighten until snug, then tighten 1/4 turn more</li> <li>6. Replace pilot assembly</li> <li>7. Replace control valve</li> </ol>
Burner does not light after pilot is lit	<ol style="list-style-type: none"> <li>1. Burner orifice clogged</li> <li>2. Inlet gas pressure is too low</li> <li>3. Thermopile leads disconnected or improperly connected</li> <li>4. Thermopile is defective</li> </ol>	<ol style="list-style-type: none"> <li>1. Clean burner (see <i>Cleaning and Maintenance</i>, page 31) or replace burner orifice</li> <li>2. Contact local propane/LP or natural gas company</li> <li>3. Reconnect leads</li> <li>4. Replace thermopile</li> </ol>
Delayed ignition burner	<ol style="list-style-type: none"> <li>1. Manifold pressure is too low</li> <li>2. Burner porting or orifice clogged</li> </ol>	<ol style="list-style-type: none"> <li>1. Contact local propane/LP or natural gas company</li> <li>2. Clean burner (see <i>Cleaning and Maintenance</i>, page 31) or replace burner orifice</li> </ol>
Burner backfiring during combustion	<ol style="list-style-type: none"> <li>1. Burner orifice is clogged or damaged</li> <li>2. Damaged burner</li> <li>3. Gas regulator defective</li> </ol>	<ol style="list-style-type: none"> <li>1. Clean burner (see <i>Cleaning and Maintenance</i>, page 31) or replace burner orifice</li> <li>2. Replace damaged burner</li> <li>3. Replace gas control</li> </ol>
Slight smoke or odor during initial operation	<ol style="list-style-type: none"> <li>1. Residues from manufacturing processes and logs curing</li> </ol>	<ol style="list-style-type: none"> <li>1. Problem will stop after a few hours of operation</li> </ol>

## TROUBLESHOOTING

*Continued*

OBSERVED PROBLEM	POSSIBLE CAUSE	REMEDY
Fireplace produces a whistling noise when burner is lit	<ol style="list-style-type: none"> <li>1. Turning gas control knob to HI position when burner is cold</li> <li>2. Air in gas line</li> <li>3. Dirty or partially clogged burner orifice</li> </ol>	<ol style="list-style-type: none"> <li>1. Turn gas control knob to LO position and let warm up for a minute</li> <li>2. Operate burner until air is removed from line. Have gas line checked by local propane/LP or natural gas company</li> <li>3. Clean burner (see <i>Cleaning and Maintenance</i>, page 31) or replace burner orifice</li> </ol>
Glass soots	<ol style="list-style-type: none"> <li>1. Flame impingement on logs</li> <li>2. Debris around burner air mixer</li> </ol>	<ol style="list-style-type: none"> <li>1. Adjust log set so that the flame does not excessively impinge in it</li> <li>2. Inspect the opening at the base of the burner to see that it is NOT packed with any type of material</li> </ol>
Fireplace produces a clicking/ticking noise just after burners are lit or shut off	<ol style="list-style-type: none"> <li>1. Metal expanding while heating or contracting while cooling</li> </ol>	<ol style="list-style-type: none"> <li>1. This is normal. If noise is excessive, contact qualified service person</li> </ol>
Remote does not function	<ol style="list-style-type: none"> <li>1. Battery is not installed or battery power is low</li> </ol>	<ol style="list-style-type: none"> <li>1. Replace 9-volt batteries in receiver and remote control</li> </ol>
Fireplace shuts off in use	<ol style="list-style-type: none"> <li>1. High or gusting winds</li> <li>2. Low line pressure</li> <li>3. Pilot is partially clogged</li> <li>4. Inner vent pipe leaking exhaust gasses into system</li> <li>5. Glass too loose and air tight gasket leaks in corners after usage</li> <li>6. Bad thermopile or thermocouple</li> <li>7. Improper vent cap installation</li> </ol>	<ol style="list-style-type: none"> <li>1. Fireplace has been tested for up to 40 mph winds. However, extreme conditions may occur. See <i>Lighting Instructions</i> on page 29</li> <li>2. Contact local propane/LP or natural gas company</li> <li>3. Clean pilot (see <i>Cleaning and Maintenance</i>, page 31)</li> <li>4. Locate and correct all leaks (see <i>Checking Gas Connections</i>, page 23)</li> <li>5. Tighten glass</li> <li>6. Replace faulty component</li> <li>7. Check for proper installation and freedom from debris or blockage</li> </ol>

## TROUBLESHOOTING

*Continued*



**WARNING: If you smell gas**

- Shut off gas supply.
- Do not try to light any appliance.
- Do not touch any electrical switch; do not use any phone in your building.
- Immediately call your gas supplier from a neighbor's phone. Follow the gas supplier's instructions.
- If you cannot reach your gas supplier, call the fire department.

OBSERVED PROBLEM	POSSIBLE CAUSE	REMEDY
Fireplace produces unwanted odors	1. Gas leak. <b>See Warning statement above</b>	1. Locate and correct all leaks (see <u><i>Checking Gas Connections</i></u> , page 23)
Gas odor even when control knob is in OFF position	1. Gas leak. <b>See Warning statement above</b> 2. Control valve defective	1. Locate and correct all leaks (see <u><i>Checking Gas Connections</i></u> , page 23) 2. Replace control valve
Gas odor during combustion	1. Gas leak. <b>See Warning statement above</b>	1. Locate and correct all leaks (see <u><i>Checking Gas Connections</i></u> , page 23)
Dark residue on logs or inside of fireplace	1. Improper log placement 2. Air holes at burner inlet blocked 3. Burner flame holes blocked 4. Improper venting or excessive blockage 5. Excessive amounts of embers and pan material	1. Properly locate logs (see <u><i>Installing Logs, Lava Rock and Glowing Embers</i></u> , page 27) 2. Clean out air holes at burner inlets. Periodically repeat as needed 3. Remove blockage or replace burner 4. Have the vent system inspected, including the termination cap. Remove any restrictions or obstruction 5. Clear excess embers until a minimum gap of 1/2" remains under the grate

# PARTS

MODELS (V)T32N-A, (V)T32NB-A, (V)T32NR-A, (V)T32NRB-A, (V)T32P-A, (V)T32PB-A, (V)T32PR-A, (V)T32PRB-A, (V)TC32(N)(P), (V)TC32(NB)(PB), (V)TC32N-HA, CGDV32NR, CGDV32PR AND CTDV32NR-HA

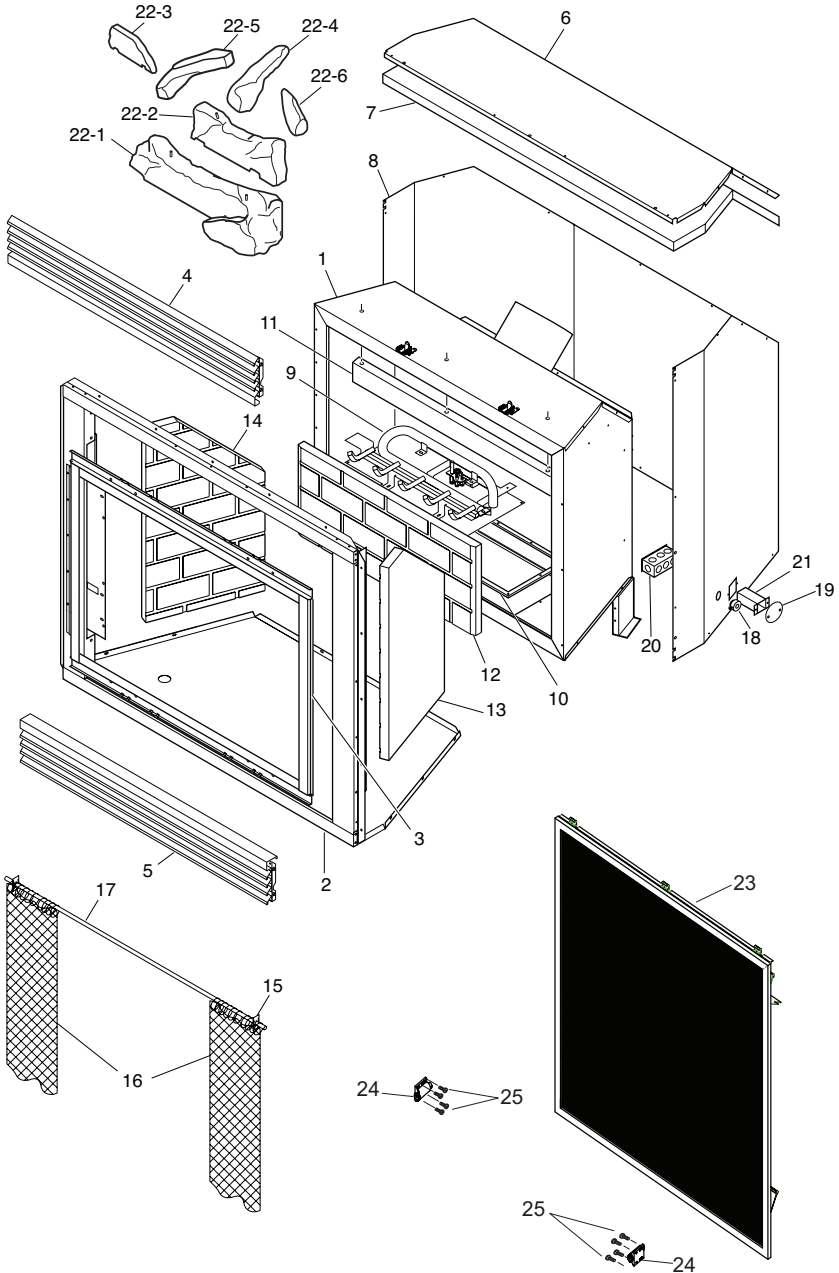

## PARTS

This list contains replaceable parts used in your fireplace. When ordering parts, follow the instructions listed under Replacement Parts on page 33 of this manual.

PART NUMBER				
KEY NO.	(VT)32N-A (VT)32P-A (VT)32NB-A (VT)32PB-A	CGDV32NR CGDV32PR CTDV32NR-HA (VT)32NR-A (VT)32PR-A (VT)32NRB-A (VT)32PRB-A (V)TC32(N)(P) (V)TC32(NB)(PB) (V)TC32N-HA	DESCRIPTION	QTY.
1	**	**	Firebox Assembly	1
2	**	**	Face Weldment	1
3	108892-01	108892-01	Door Assembly (T & CGDV Models Only)	1
	108892-02	108892-02	Door Assembly (VT Models Only)	1
4	109155-01	108903-01	Top Louver/Panel Assembly	
5	109155-02	108903-02	Bottom Louver/Panel Assembly	1
6	**	**	Fireplace Top	1
7	**	**	Fireplace Top Insulation	1
8	**	**	Fireplace Surround	1
9	108885-01	108885-01	Burner Assembly (Natural Gas)	1
	108885-02	108885-02	Burner Assembly (Propane/LP Gas) (See page 40 & 41)	1
10	108890-01	108890-01	Burner Base Gasket	1
11	109082-03	109082-03	Heat Shield	1
12	108897-01	108897-01	Rear Refractory Brick Panel (B Models Only)	1
13	108901-01	108901-01	Right Refractory Brick Panel (B Models Only)	1
14	108901-02	108901-02	Left Refractory Brick Panel (B Models Only)	1
15	11418	11418	Push-On Nut	2
16	12125	12125	Screen	2
17	109479-01	109479-01	Screen Rod	1
18	14123	14123	Strain Relief	1
19	21171	21171	Gas Knock-Out Cover	2
20	24353	24353	Handy Box Assembly	1
21	24460	24460	Gas Conduit Assembly	1
22	109222-01	109222-01	Log Set	1
22-1	109403-01	109403-01	Front Log (No. 1)	1
22-2	109404-01	109404-01	Rear Log (No. 2)	1
22-3	109407-01	109407-01	Base Log (No. 3)	1
22-4	109406-01	109406-01	Crossover Log (No. 4)	1
22-5	109405-01	109405-01	Left Top Log (No. 5)	1
22-6	109408-01	109408-01	Right Top Log (No. 6)	1
23		125408-03	Screen Door (TC Models Only)	1
24		125519-01	Door Latch Magnet (TC Models Only)	2
25		125558-01	Door Latch Screw (TC Models Only)	8
<b>PARTS AVAILABLE - NOT SHOWN</b>				
	25487	25487	Lava Rock/Bag Assembly	1
		PCDM-32T	Propane/LP Gas Conversion Kit (model CTDV32NR-HA only)	1

\*\* Not a field replaceable part.

## PARTS

BURNER ASSEMBLY MODELS (V)T32N-A, (V)T32NB-A, (V)T32NR-A, (V)T32NRB-A, (V)T32P-A, (V)T32PB-A, (V)T32PR-A, (V)T32PRB-A, (V)TC32(N)(P), (V)TC32(NB)(PB), TC32N-HA CGDV32NR, CGDV32PRAND CTDV32NR-HA

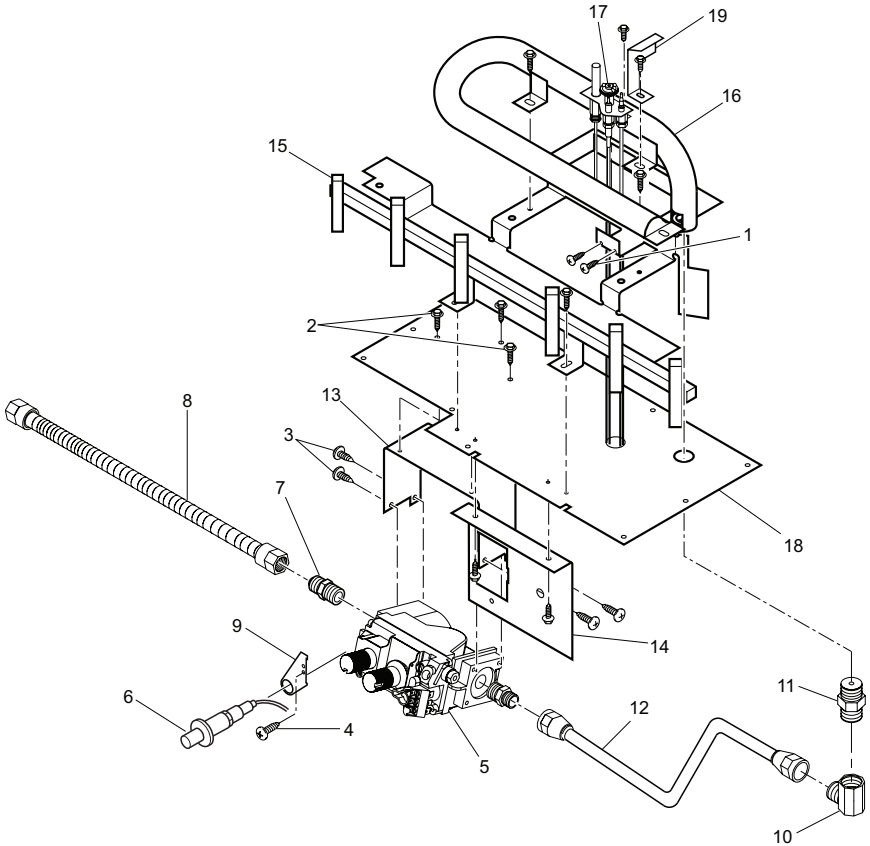



## PARTS

### BURNER ASSEMBLY MODELS (V)T32N-A, (V)T32NB-A, (V)T32NR-A, (V)T32NRB-A, (V)T32P-A, (V)T32PB-A, (V)T32PR-A, (V)T32PRB-A, (V)TC32(N)(P), (V)TC32(NB)(PB), (V)TC32N-HA, CGDV32NR, CGDV32PR AND CTDV32NR-HA

This list contains replaceable parts used in your fireplace. When ordering parts, follow the instructions listed under Replacement Parts on page 33 of this manual.

KEY			
NO.	PART NO.	DESCRIPTION	QTY.
1	11102	Screw #8-32 x 3/8 PPH Zinc	2
2	11105	Screw #10 x 1/2 Zinc	9
3	11179	Screw #10-24 x 1/4 Zinc	4
4	11237	Screw, Trilab M4 x 8 mm	1
5	14389	Millivolt Valve (Natural Gas)	1
	14390	Millivolt Valve (Propane/LP Gas)	1
	117370-01	Millivolt Valve (NG-High Altitude)	1
6	14492	Piezo Ignitor	1
7	14500	Brass Fitting	2
8	14253	Flexible Connector	1
9	14511	Ignitor Bracket	1
10	14528	Brass Elbow Fitting	1
11	104506-25	Orifice (Natural #47)	1
	104506-02	Orifice (Propane/LP #55)	1
12	104509-02	Aluminum Tubing Assy	1
13	26808	Valve Bracket	1
14	26827	Switch Bracket	1
15	108886-01	Base Grate Assembly	1
16	108891-01	Burner	1
17	108084-02	Pilot Assembly (Natural)	1
	108084-03	Pilot Assembly (Propane/LP)	1
	108084-05	Pilot Assembly (NG-High Altitude)	1
18	**	Burner Base Assembly	1
19	27113	Air Deflector	1

\*\* Not a field replaceable part.

## ACCESSORIES

**NOTICE: All accessories may not be available for all fireplace models.**

Purchase these accessories from your local dealer. If they can not supply these accessories call FMI PRODUCTS, LLC at 1-866-328-4537 for information. You can also write to the address listed on the back page of this manual.

### REFRACTORY BRICK LINER KIT BL32DS

This brick liner adds a touch of style to your direct-vent fireplace. Complete installation instructions included in this manual.

**BLX32STL** - Ledgestone Refractory Kit

**BLX32SVF** - Fiber Liner Kit

**PLX32** - Porcelain Liner Kit

### PROPANE/NATURAL GAS CONVERSION KIT

**PCDM-32T** - Propane/LP Gas Conversion Kit

**NCDM-32T** - Natural Gas Conversion Kit

### FACE/LOUVER PANEL KIT

**RLD32** - Rolled Louver Panels, Black

### LOUVER TRIM KIT (Rolled Louvers Only)

**LT32B** - Brushed Brass

**LT32P** - Platinum

### DEFLECTION HOOD

**HD32** - Hood - Black (2" Brow)

### PERIMETER TRIM KIT

**PT32** - Black

**PT32B** - Brushed Brass

**PT32P** - Platinum

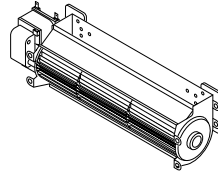

### MANUAL BLOWER KIT - BK

Manual variable control blower accessory provides better heat distribution. Complete installation and operation instructions included in this manual.

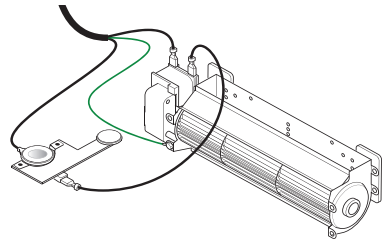

### THERMOSTATICALLY- CONTROLLED BLOWER KIT - BKT

Provides better heat distribution. Blower turns off and on automatically, as needed. Complete installation and operation instructions included in this manual.

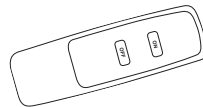

### RECEIVER AND HAND-HELD ON/OFF REMOTE CONTROL KIT - MRC

**For all Remote-Ready Models.** Allows the fireplace to be turned on and off conveniently.

### WALL MOUNTED ON/OFF SWITCH GWMS2

Allows burner system to be turned on and off with a wall switch.



# WARRANTY

## KEEP THIS WARRANTY

Model (located on product or identification tag) \_\_\_\_\_

Serial No. (located on product or identification tag) \_\_\_\_\_

Date Purchased \_\_\_\_\_

Keep receipt for warranty verification.

## FMI PRODUCTS, LLC LIMITED WARRANTIES

### New Products

**Standard Warranty:** FMI PRODUCTS, LLC warrants this new product and any parts thereof to be free from defects in material and workmanship for a period of four (4) years from the date of first purchase from an authorized dealer provided the product has been installed, maintained and operated in accordance with FMI PRODUCTS, LLC's warnings and instructions.

For products purchased for commercial, industrial or rental usage, this warranty is limited to 90 days from the date of first purchase.

### Factory Reconditioned Products

**Limited Warranty:** FMI PRODUCTS, LLC warrants factory reconditioned products and any parts thereof to be free from defects in material and workmanship for 30 days from the date of first purchase from an authorized dealer provided the product has been installed, maintained and operated in accordance with FMI PRODUCTS, LLC's warnings and instructions.

### Terms Common to All Warranties

The following terms apply to all of the above warranties:

Always specify model number and serial number when contacting the manufacturer. To make a claim under this warranty the bill of sale or other proof of purchase must be presented.

This warranty is extended only to the original retail purchaser when purchased from an authorized dealer, and only when installed by a qualified installer in accordance with all local codes and instructions furnished with this product.

This warranty covers the cost of part(s) required to restore this product to proper operating condition and an allowance for labor when provided by a FMI PRODUCTS, LLC Authorized Service Center or a provider approved by FMI PRODUCTS, LLC. Warranty parts must be obtained through authorized dealers of this product and/or FMI PRODUCTS, LLC who will provide original factory replacement parts. Failure to use original factory replacement parts voids this warranty.

Travel, handling, transportation, diagnostic, material, labor and incidental costs associated with warranty repairs, unless expressly covered by this warranty, are not reimbursable under this warranty and are the responsibility of the owner. All warranty will be voided if this product is used with a thermostat.

Excluded from this warranty are products or parts that fail or become damaged due to misuse, accidents, improper installation, lack of proper maintenance, tampering, or alteration(s).

This is FMI PRODUCTS, LLC's exclusive warranty, and to the full extent allowed by law; this express warranty excludes any and all other warranties, express or implied, written or verbal and limits the duration of any and all implied warranties, including warranties of merchantability and fitness for a particular purpose to four (4) years on new products and 30 days on factory reconditioned products from the date of first purchase. FMI PRODUCTS, LLC makes no other warranties regarding this product.

FMI PRODUCTS, LLC's liability is limited to the purchase price of the product, and FMI PRODUCTS, LLC shall not be liable for any other damages whatsoever under any circumstances including indirect, incidental, or consequential damages.

Some states do not allow limitations on how long an implied warranty lasts or the exclusion or limitation of incidental or consequential damages, so the above limitation or exclusion may not apply to you.

This warranty gives you specific legal rights, and you may also have other rights which vary from state to state.

For information about this warranty contact:

  
**FMI PRODUCTS, LLC**  
2701 S. Harbor Blvd.  
Santa Ana, CA 92704  
1-866-328-4537  
[www.fmiproducts.com](http://www.fmiproducts.com)

116646-01  
Rev. N  
04/13