

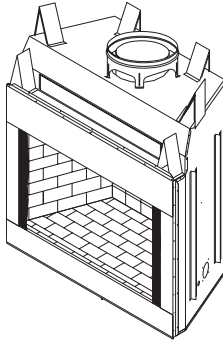

**RESIDENTIAL WOOD BURNING FIREPLACE  
OWNER'S OPERATION AND INSTALLATION MANUAL**



**(V)GM36, (V)GM42 AND (V)GM50 WOOD BURNING MASONRY  
FIREPLACES WITH INSULATION  
(V)GM36H, (V)GM42H AND (V)GM50H WOOD BURNING  
HERRINGBONE MASONRY FIREPLACES WITH INSULATION**

**SAVE THIS BOOK**

This book is valuable. In addition to instructing you on how to install and maintain your appliance, it also contains information that will enable you to obtain replacement parts or accessory items when needed. Keep it with your other important papers.

This fireplace is approved for use as a wood burning fireplace or for use with a vented gas log approved to ANS Z21.60, Z21.84 or RGA 2-72 standards or for use with a vent-free gas log heater approved to ANS Z21.11.2 standard.

This wood burning fireplace complies with UL127-CAN/ULS-S610-M87 standard as a **FACTORY BUILT APPLIANCE**.

**FOR CANADA:** The authority having jurisdiction (such as the municipal building department, fire department, etc.) should be contacted before installation to determine the need to obtain a permit.

**INSTALLER:** Leave this manual with the appliance.  
**CONSUMER:** Retain this manual for future reference.

**⚠ WARNING: Improper installation, adjustment, alteration, service or maintenance can cause injury, property damage or loss of life. Refer to this manual for assistance or additional information. Consult a qualified installer or local distributor.**

## TABLE OF CONTENTS

Safety .....	2	Brick Installation .....	14
Specifications .....	3	Glass Door Installation .....	22
Fireplace Installation.....	6	Operation and Maintenance Guidelines .....	23
Venting Installation .....	8	Replacement and Accessory Parts.....	25
Optional Gas Line Installation.....	13	Technical Service.....	26

## SAFETY

**IMPORTANT: Check local codes before installing this fireplace.**

Before beginning the installation of the fireplace, read these instructions through completely.

- This DESA Heating, LLC fireplace and its components are safe when installed according to this installation manual. Unless you use DESA Heating, LLC components, which have been designed and tested for the fireplace system, you may cause a fire hazard.
- The DESA Heating, LLC warranty will be voided by and DESA Heating, LLC disclaims any responsibility for the following actions.
  - a. Modification of the fireplace, components, doors, air inlet system and damper control.
  - b. Use of any component part not manufactured or approved by DESA Heating, LLC in combination with a DESA Heating, LLC fireplace system.

Proper installation is the most important step in ensuring safe and continuous operation of the fireplace. Consult the local building codes as to the particular requirements concerned with the installation of all factory built fireplaces.

**⚠ WARNING: Do not install a fireplace insert in this box unless the manufacturer's instructions with the insert specifically state this fireplace has been tested for use with this insert.**

**This fireplace is not intended to be used as a substitute for a furnace to heat an entire home. Use for supplemental heat only.**

### FOR YOUR SAFETY

- **Do not store or use gasoline or any other flammable vapors or liquids in the vicinity of this or any other appliance.**
- **Due to high temperatures, the appliance should be located out of traffic and away from furniture and draperies.**
- **Do not place clothing or other flammable materials on or near the appliance.**
- **Never leave children unattended when a fire is burning in the fireplace.**

**⚠ WARNING: Use solid wood or processed solid fuel firelogs only. When processed wood fuel fire logs are used, do not poke or stir the logs while they are burning. Use only fire logs that have been evaluated for the application in fireplace and refer to fire log warnings and caution markings on packaging prior to use.**

# SAFETY

Continued

**⚠ WARNING: Always leave glass doors fully opened or fully closed when operating fireplace.**

## SPECIFICATIONS

MODELS VGM36(H) AND GM36(H)

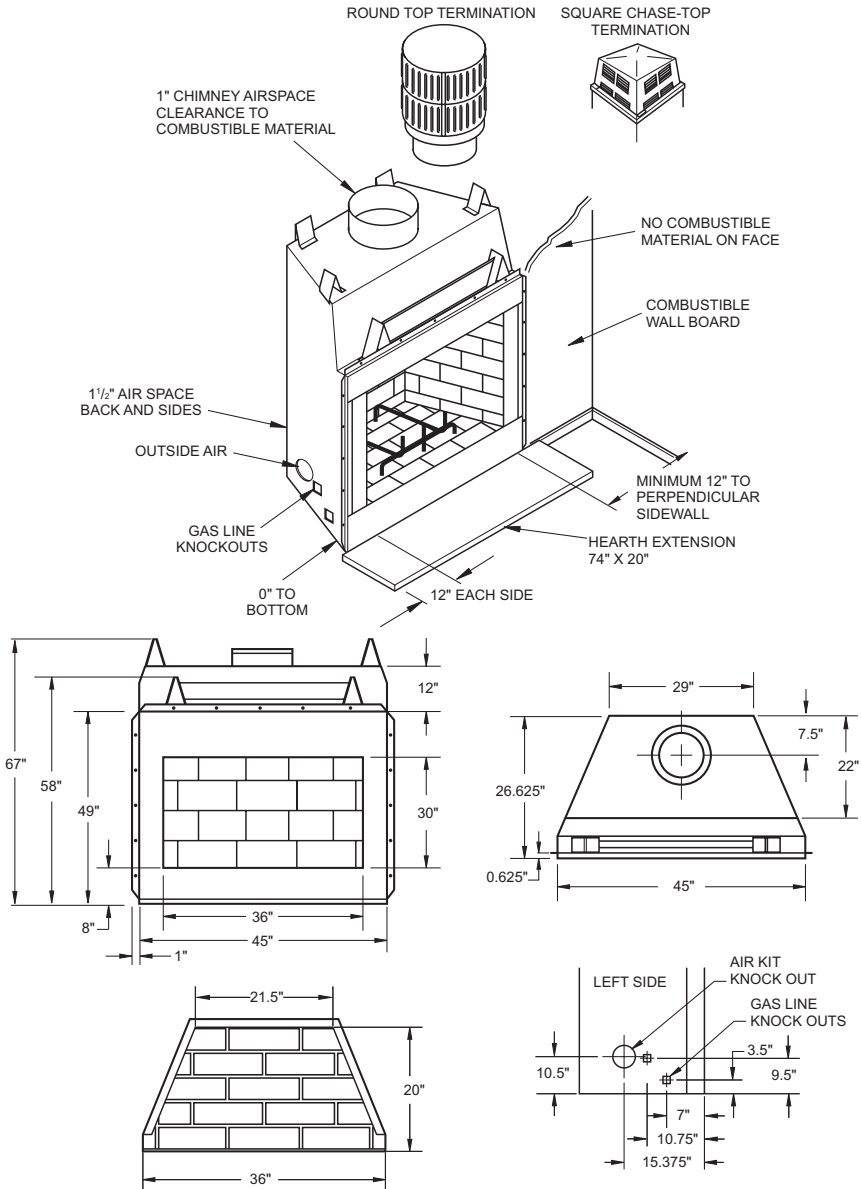

# SPECIFICATIONS

*Continued*

## MODELS VGM42(H) AND GM42(H)

ROUND TOP TERMINATION

SQUARE CHASE-TOP  
TERMINATION

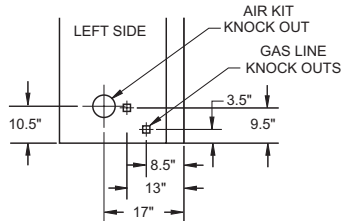
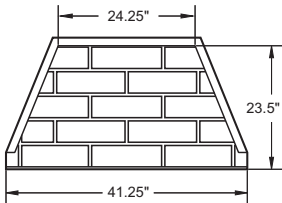
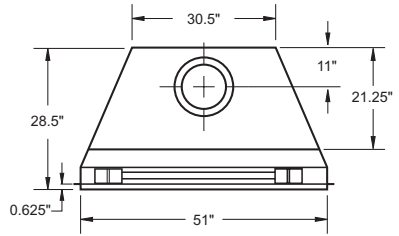
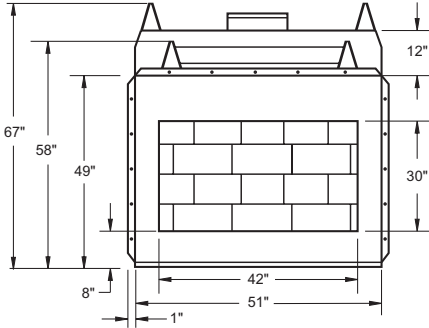
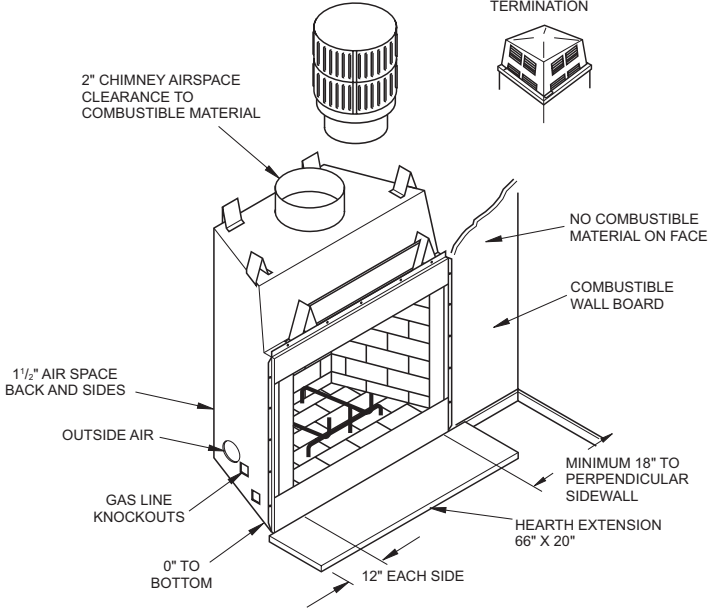

# SPECIFICATIONS

*Continued*

## MODELS VGM50(H) AND GM50(H)

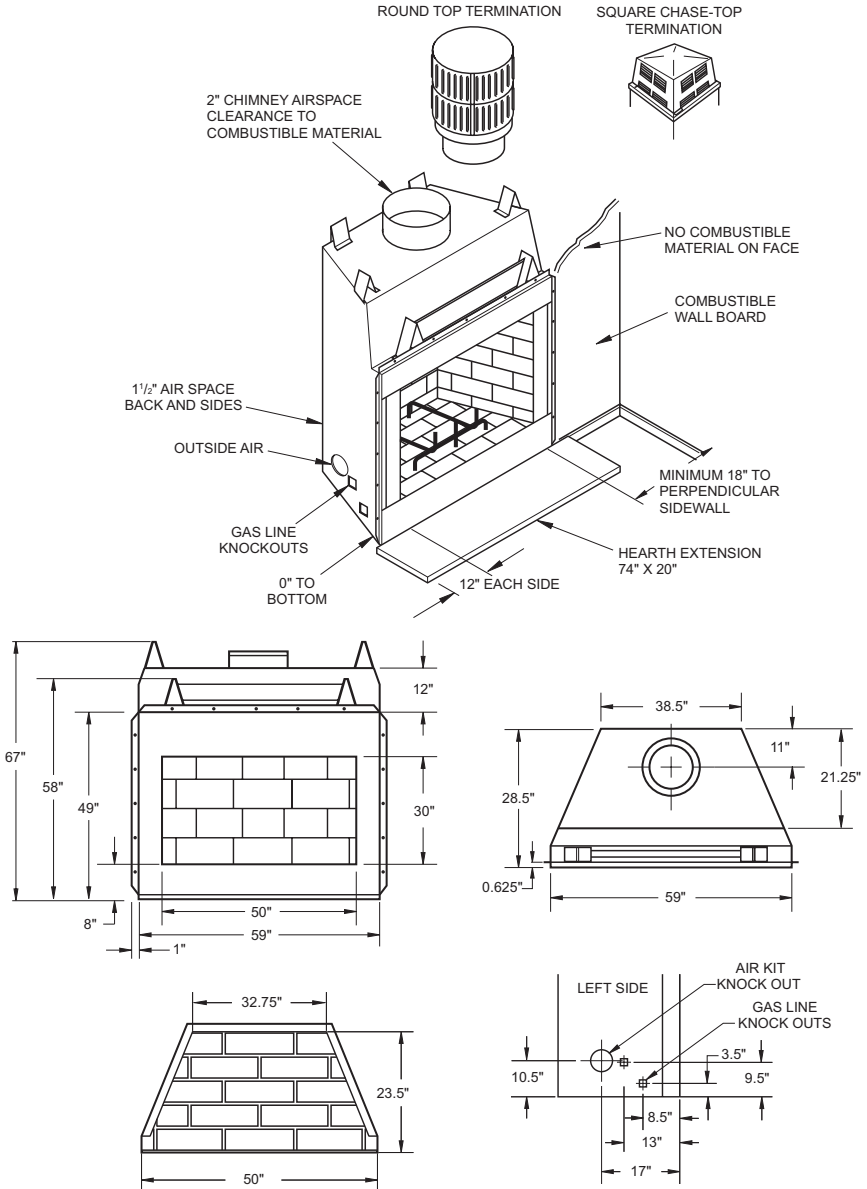

# FIREPLACE INSTALLATION

## SELECTING LOCATION

To determine the safest and most efficient location for the fireplace, you must take into consideration the following guidelines:

1. The location must allow for proper clearances (see Figures 1 and 2).
2. Consider a location where the fireplace will not be affected by drafts, air conditioning ducts, windows or doors.
3. A location that avoids the cutting of joists or roof rafters will make installation easier.
4. An outside air kit is available with this fireplace (see *Optional Outside Air Kit* on page 8).

## MINIMUM CLEARANCE TO COMBUSTIBLES

Back and sides of fireplace	1 1/2" min.*
Front of fireplace	48" min.
Floor**	0" min.
Perpendicular wall to opening	18" min.
Model GM36	12" min.
Top spacers	0" min.
Mantel clearance	see <i>Mantels</i> , page 7
Chimney outer pipe surface	2" min.
Models GM36	1" min.

\* Not required at nailing flanges

\*\* See step 2 of *Framing*

**WARNING: Do not pack required air spaces with insulation or other materials.**

## Minimum/Maximum Chimney Height

The minimum height of the chimney, measured from the base of the fireplace to the flue gas outlet of the termination, is 16 feet for straight flue or a flue with one elbow set. The maximum distance between elbows is 6 feet. For systems with two elbow sets, the minimum height is 22 feet. The maximum height of any system is 50 feet. This measurement includes the fireplace, chimney sections and the height of the termination assembly at the level of the flue gas outlet (see Figure 15, page 11).

## FRAMING

1. Frame the opening for the fireplace using the dimensions shown in Figures 1 and 2.

2. If the fireplace is to be installed directly on carpeting, tile (other than ceramic) or any combustible material other than wood flooring, the fireplace must be installed upon a metal or wood panel extending the full width and depth of the fireplace.
3. Set the fireplace directly in front of this opening and slide the unit back until the nailing flanges touch the side framing.
4. Check the level of the fireplace and shim with sheet metal if necessary.
5. Before securing fireplace to prepared framing, the ember protector (provided) must be placed between the hearth extension (not supplied) and under the bottom front edge of the fireplace to protect against glowing embers falling through. If the fireplace is to be installed on a raised platform, a Z-type ember protector (not supplied) must be fabricated to fit your required platform height. The ember protector should extend under the fireplace a minimum of 1 1/2". The ember protector should be made of galvanized sheet metal (28 gauge minimum) to prevent corrosion.
6. Using screws or nails, secure the fireplace to the framing through flanges located on the sides of the fireplace.

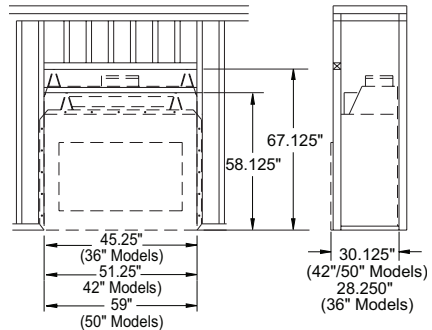

**Figure 1 - Framing Dimensions**

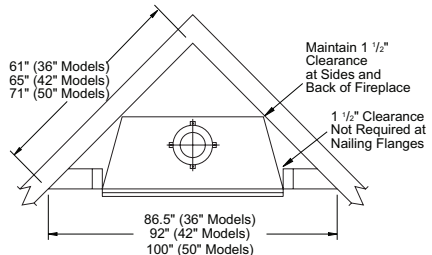

**Figure 2 - Corner Installation**

# FIREPLACE INSTALLATION

Continued

## HEARTH EXTENSION

A hearth extension projecting a minimum of 20" in front of and a minimum of 12" beyond each side of the fireplace opening is required to protect combustible floor construction in front of the fireplace. Fabricate a hearth extension using a material which meets the following specifications: a layer of noncombustible, inorganic material having a thermal conductivity of  $K=0.84$  BTU IN/FT, HR. F (or less) at 1" thick. For example, if the material selected has a K factor of 0.25, such as glass fiber, the following formula would apply:

$$\frac{0.25}{0.84} \times 1.0" = 0.30" \text{ thickness required}$$

Thermal conductivity "K" of materials can be obtained from the manufacturer or supplier of the noncombustible material. If the hearth extension is to be covered, use noncombustible material such as tile, slate, brick, concrete, metal, glass, marble, stone, etc. Provide a means to prevent the hearth extension from shifting and seal gap between the fireplace frame and hearth extension with a noncombustible material (see Figure 3).

**WARNING: Hearth extension is to be installed only as shown in Figure 3.**

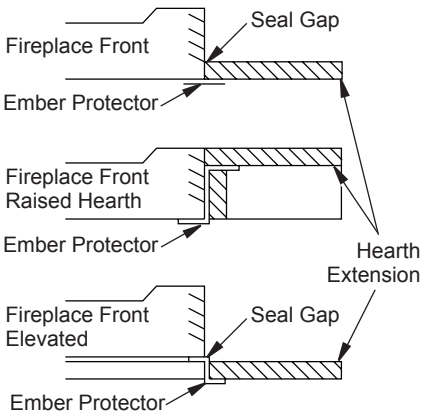

Figure 3 - Hearth Extension

## MANTELS

A mantel may be installed if desired (see Figure 4). Woodwork such as wood trims, mantels or any other combustible material projecting from the front face must not be placed within 12" (GM36) or 18" (GM42/50) of the fireplace opening. Combustible materials above 12" (GM36) or 18" (GM42/50) and projecting more than 1 1/2" from the fireplace must not be placed less than 15" (GM36) or 21" (GM42/50) from the top opening of the fireplace (NFPA STD 211, Sec. 7-3.3.3).

Mantels or any other combustible material also may come up to the side edge of the black metal face of the fireplace just as long as the projection from the front face fall within the limit shown in Figure 4.

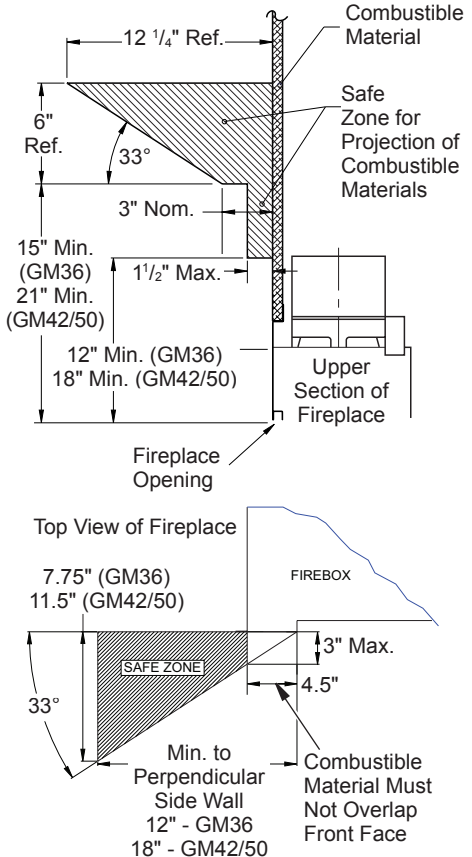

Figure 4 - Mantel Clearances to Combustible Material

# VENTING INSTALLATION

## OPTIONAL OUTSIDE AIR KIT (MODEL AK4/AK4F)

The installation of an outside air kit should be performed during the rough framing of the fireplace due to the nature of its location. Outside combustion air is accessed through a vented crawl space (AK4F) or through a sidewall (AK4).

**CAUTION: Combustion air inlet ducts shall not terminate in attic space.**

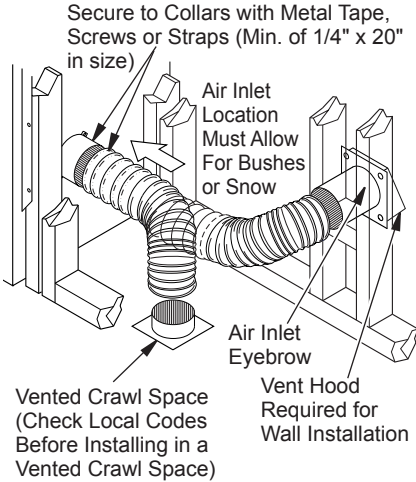

Figure 5 - Outside Air Kit

## CHIMNEY PIPE

The DESA Heating, LLC chimney system consists of 12", 18", 24", 36" and 48" snap-lock, double-wall pipe segments, planned for maximum adaptability to individual site requirements. Actual lengths gained after fitting overlaps must be taken into consideration (lineal gain) and are given in the lineal gain chart (see Figure 6). Lineal Gain is the actual measurable length of a part after two or more parts are connected. For Canada, use chimney parts designated "HT".

**WARNING: The opening in the collar around the chimney at the top of the fireplace must not be obstructed. Never use blown insulation to fill the chimney enclosure.**

LINEAL GAIN		
PART NO.	DESCRIPTION	GAIN (IN)
Georgian	Fireplace	66 1/2"
12-12DM	Pipe Section	10 5/8"
12-12HT		
18-12DM	Pipe Section	16 5/8"
18-12HT		
24-12DM	Pipe Section	23 5/8"
24-12HT		
36-12DM	Pipe Section	34 5/8"
36-12HT		
48-12DM	Pipe Section	46 5/8"
48-12HT		
RLT-12D	Round Termination	7 3/4"*
RLT-12HT		
STL-12D	Square Chase-Top with Slip Section	7" to 15"**

\* The lineal gain for the terminations is measured to the flue gas outlet height.

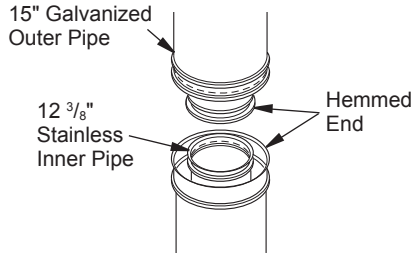

Figure 6 - Lineal Gain

## ASSEMBLY AND INSTALLATION OF DOUBLE WALL CHIMNEY SYSTEM

Each double wall chimney section consists of a galvanized outer pipe, a stainless steel inner flue pipe and a wire spacer. Pipe sections must be assembled independently as chimney is installed. When connecting chimney directly to fireplace, inner flue pipe section must be installed first with lanced side up. Outer pipe section can then be installed over flue pipe section with hemmed end up. Press down on each pipe section until lances securely engage hem on fireplace starter. The wire will assure proper spacing between the inner and outer pipe sections.



# VENTING INSTALLATION

*Continued*

Continue to assemble chimney sections as outlined above, making sure both inner and outer pipe sections are locked together. When installing double wall snap-lock chimney together, it is important to assure joint between chimney sections is locked. Check by pulling chimney upward after locking. The chimney will not come apart if properly locked. It is not necessary to add screws to keep chimney together (exception, see Figure 7).

OFFSET A	RISE B	CHIMNEY LENGTH				
		12"	18"	24"	36"	48"
4 3/8"	16 3/8"	ELBOW SET ONLY				
9 3/4"	25 1/2"	1				
12 3/4"	30 3/4"		1			
15"	34 3/4"			1		
18"	40"	1	1			
21 1/4"	46 1/4"				1	
23 3/4"	49 1/4"		1	1		
27 3/4"	56 3/4"					1
30"	60 3/4"		1		1	
33"	66"					1
36"	71"		1			1
38 1/4"	75"				2	
41 1/4"	80 1/4"	1	1		1	
45"	86 3/4"				2	
46 3/4"	89 1/2"	1	1			1
51"	97"				1	1
53 1/4"	101"				2	
56 1/4"	106 1/4"					2
59 1/4"	111 1/2"		1		1	1
61 3/4"	115 1/2"	1				2
64 3/4"	120 3/4"		1			2
68 1/4"	127"				2	1
70"	130"		1	1		2
74 1/4"	137 1/2"	1			2	1
76 3/4"	141 1/2"		1		2	1
79 3/4"	146 3/4"				4	

**OFFSET CHART (22-50 FT. SYSTEM HEIGHT)**

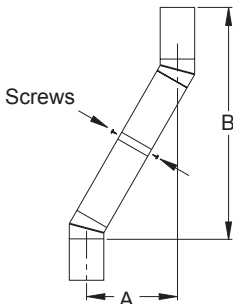

**Figure 7 - Elbow Offset**

## USING ELBOW OFFSETS (30E-12DM)

- To achieve desired offset, you may install combinations of 12", 18", 24", 36" and 48" length of double wall pipe (see offset chart and Figure 7).
- Chimney weight above offset rests on return elbow. Straps must be securely nailed to rafters or joists (see Figure 8, details a and b).
- Maximum length of pipe between supports (return elbow or 12S-12DM) is 6' of angle run. Maximum of two 6' angle run sections per chimney system (see Figure 9, page 10).
- All pipe connections between the offset and return must be secured with two screws on the outer pipe only (see Figure 7). Do not penetrate the inner stainless.

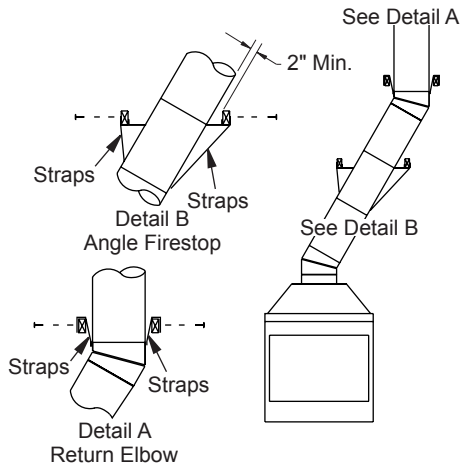

**Figure 8 - Ceiling Support Pipe 12S-12DM**

# VENTING INSTALLATION

Continued

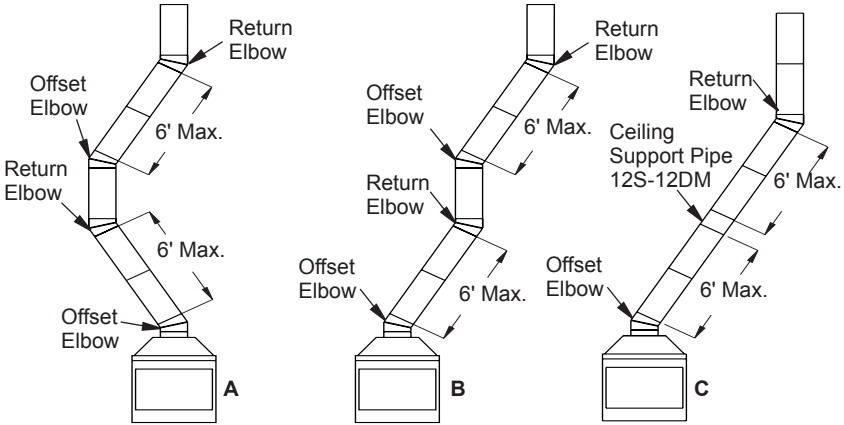

Figure 9 - Typical Offset Terminations

## FIRESTOP SPACERS (FS-10, 1100EFS-10DM FOR GM36)

Firestop spacers are required at each point where the chimney penetrates a floor space. Their purpose is to establish and maintain the required clearance between the chimney and the combustible materials. When the pipe passes through a framed opening into a living space above, the firestop must be placed onto the ceiling from below as shown in Figure 10.

They also provide complete separation from one floor space to another or attic space as required by most codes. When the double wall pipe passes through a framed opening into an attic space, the firestop must be placed into an attic floor as shown in Figure 11.

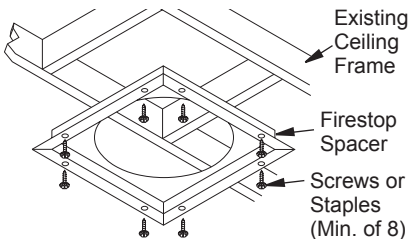

Figure 10 - Firestop Spacer with Living Space Above Ceiling

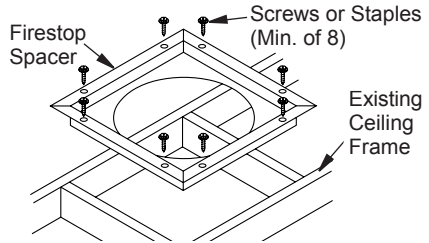

Figure 11 - Firestop Spacer with Attic Space Above Ceiling

## PENETRATING THE ROOF

To maintain a 1" (GM36) or 2" (GM42/GM50) clearance to the pipe on a roof with a pitch, a rectangular opening must be cut.

1. Determine the center point through which the pipe will penetrate the roof.
2. Determine the center point of the roof. Pitch is the distance the roof drops over a given span, usually 12". A 6/12 pitch means that the roof drops 6" for each 12" one measure horizontally down from the roof rafters.
3. Use the roof opening chart (Figure 12, page 11) to determine the correct opening length and flashing required.
4. Remove the shingles around the opening measured. Cut out this section.

# VENTING INSTALLATION

*Continued*

5. Add the next sections of the pipe until the end penetrates the roof line. Check to see that the proper clearances are maintained. Extend chimney by adding sections of double wall pipe until pipe is minimum of 30" above the highest point of the roof cut-out. Termination and chimney must extend a minimum of 36" above the highest point where it passes through the roof.

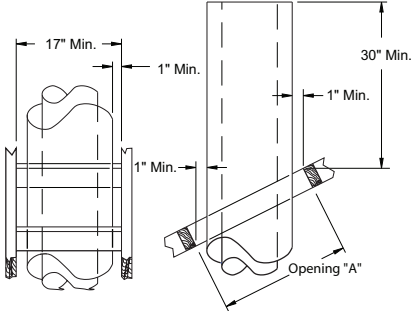

Pitch	Slope	Opening "A" Max.	Used Flashing Model No.
Flat	0°	17"	V6F-10DM
0-6/12	26.6°	19"	V6F-10DM
6/12-12/12	45.0°	24"	V12F-10DM

**Roof Opening GM36**

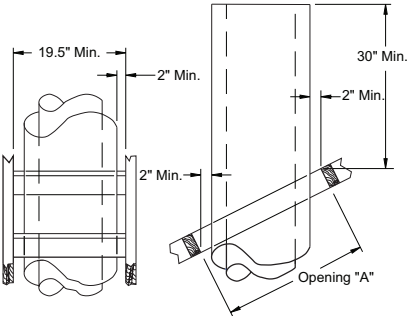

Pitch	Slope	Opening "A" Max.	Used Flashing Model No.
Flat	0°	19.5"	V6F-10DM
0-6/12	26.6°	22"	V6F-10DM
6/12-12/12	45.0°	27"	V12F-10DM

**Roof Opening GM42/50**

**Figure 12 - Roof Opening Measurements**

## FLASHING INSTALLATION (V6F-10DM OR V12F-10DM)

Determine the flashing to be used with the roof opening chart. Slide flashing over pipe until base is flat against roof. Replace as many shingles as needed to cover exposed area and flashing base. Secure in position by nailing through shingles (see Figure 13). DO NOT NAIL THROUGH FLASHING CONE.

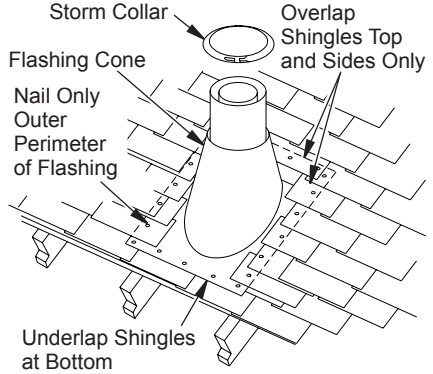

**Figure 13 - Flashing Installation**

## Installing Flashing on a Metal Roof

When installing the flashing on a metal roof, it is required that putty tape be used between the flashing and the roof. The flashing must be secured to the roof using #8 x 3/4" screws and then sealed with roof coating to prevent leakage through the screw holes. A roof coating must also be applied around the perimeter of the flashing to provide a proper seal.

## Storm Collar Installation (SC2-1)

Place storm collar over pipe and slide down until it is snug against the open edge of the flashing (see Figure 14). Apply waterproof caulk around the perimeter of the collar to provide a proper seal.

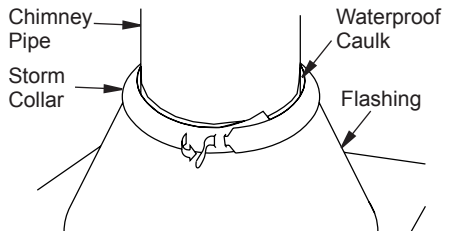

**Figure 14 - Storm Collar**

# VENTING INSTALLATION

Continued

## Terminations/Spark Arrestor

The fireplace system must be terminated with the listed round top or chase terminations. In any case, refer to the installation instructions supplied with the termination.

**CAUTION:** Do not seal openings on the rooftop flashing. Follow the installation instructions provided with the termination being used.

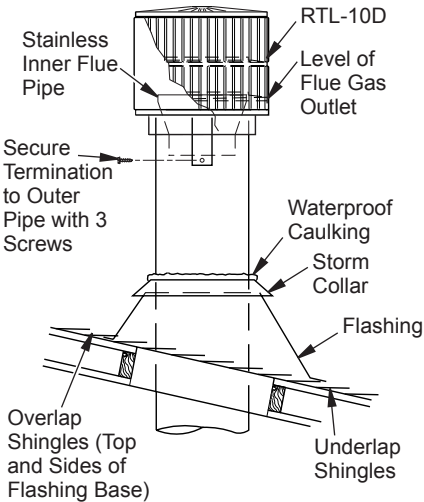

Figure 15 - Termination

## CHASE INSTALLATIONS

Instructions for chase installations are included with the chase style termination chosen. In a multiple chase installation, be sure to provide adequate distance between terminations to prevent smoke spillage from one termination to another. We suggest that terminations be separated at least 24" center to center and stacked at a vertical height difference of 18" (see Figure 16).

Note: If a decorative shroud is to be installed, contact the manufacturer for specifications.

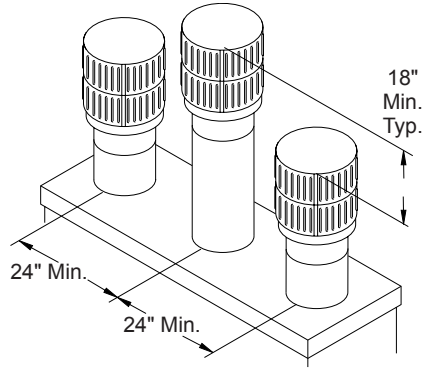

Figure 16 - Multiple Chase Installation

## 10 FOOT RULE

All flue gas outlet chimney terminations must extend a minimum of 3 feet in height above the highest point where it passes through the roof and must be at least 2 feet above the highest point of the roof that is within a horizontal distance of 10 feet (see Figure 17).

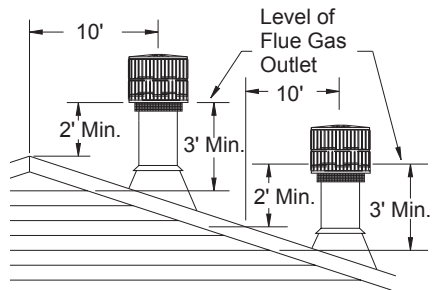

Figure 17 - 10 Foot Rule

## FINISHING THE FIREPLACE

Combustible materials, such as wallboard, gypsum board, sheet rock, drywall, plywood, etc. may make direct contact with sides and top around the fireplace face. It is important that combustible materials do not overlap the face itself. Brick, glass, tile or other noncombustible materials may overlap the front face provided they do not obstruct essential openings like louvered slots or any other opening. When overlapping with a noncombustible facing material, use only noncombustible mortar or adhesive.

## OPTIONAL GAS LINE INSTALLATION

Gas line hook up should be done by your supplier or a qualified service person.

*Note: Before you proceed, make sure your gas supply is turned off.*

Use only a 1/2" black iron pipe and appropriate fittings.

1. Remove knockout indentation on refractory or firebrick wall located above refractory hearth floor. The knockout indentation must be firmly tapped with any solid object such as a 1/2" dowel until it is released. Remove fragmented portions of refractory (see Figure 18).
2. Remove gas line cover plate located on either side of fireplace and pull out insulation from gas line conduit sleeve. Save insulation for reuse. Replace screws.
3. Run a 1/2" black iron gas line into fireplace through rear at gas line conduit sleeve (if using a raised platform, add height). Provide sufficient gas line into fireplace chamber for fitting connection (see Figure 19).

*Note: Secure incoming gas line to wood framing to provide rigidity for threaded end.*

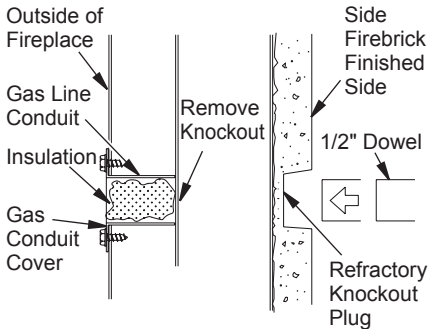

**Figure 18 - Gas Line Knockout**

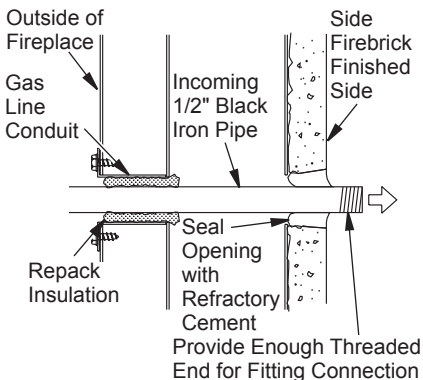

**Figure 19 - Gas Line Installation**

4. Repack insulation around gas line and into sleeve opening. Seal any gaps between gas line and refractory knockout hole with refractory cement or commercial furnace cement. Install gas appliance or cap-off gas line if desired.

**⚠ CAUTION: All gas piping and connections must be tested for leaks after the installation is completed. After ensuring that the gas valve is on, apply soap and water solution to all connections and joints. Bubbles forming show a leak. Correct all leaks at once. DO NOT USE AN OPEN FLAME FOR LEAK TESTING AND DO NOT OPERATE ANY APPLIANCE IF A LEAK IS DETECTED. LEAK TESTING SHOULD BE DONE BY A QUALIFIED SERVICE PERSON.**

**⚠ WARNING: Do not operate an unvented gas log set in this fireplace with the chimney removed.**

If you install a decorative gas appliance (vented gas log), the decorative gas appliance must comply with the *Standard for Decorative Gas Appliance for Installation in Solid Fuel Burning Fireplaces, ANS Z21.60, Z21.84 or RG 2-72* and shall also be installed in accordance with the *National Fuel Gas Code, ANSI Z223NFPA 54 latest edition*.

**⚠ WARNING: If the fireplace has been used for wood burning, the firebox and chimney must be cleaned of soot, creosote and ashes by a qualified chimney cleaner. Creosote will ignite if heavily heated.**

**⚠ WARNING: When using a decorative vented gas log, the damper must be removed or permanently locked in the fully open position and the glass doors must be in the fully open position.**

## BRICK INSTALLATION

**Installation of brick should be done after the fireplace is placed in a permanent location.**

Brick housing panels are already installed in firebox. Each housing is stamped with a letter (full size bricks are not stamped). These letters will help identify the brick when installing. It is important to install these bricks exactly as instructed. Press brick firmly into brick housing until it snaps. Groove line on side of brick will come in contact with flange on brick housing. This secures brick into housing. See Figure 20.

Bricks are packaged in four separate boxes. These boxes are labeled by sections of firebox.

Box #1 - Hearth Panel

Box #2 - Rear Panel

Box #3 - Left or Right Panel

Box #4 - Left or Right Panel

Install bricks one section at a time starting with hearth panel followed by rear panel and then left or right panel. It is important to install bricks in sequence.

*Note: The left and right panels have identical bricks. Please note, full size bricks are NOT stamped.*

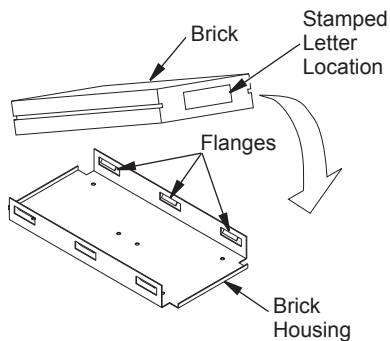

**Figure 20 - Installing Brick**

### INSTALLING BRICK "S"

Use brick "S" if an optional gas line is installed. Mount brick "S" as shown in Figure 21. It is important that the knockout hole is in its proper location. The knockout hole on brick "S" should align with hole on brick housing.

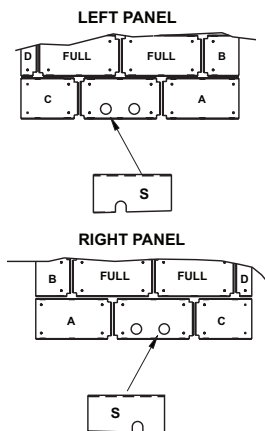

**Figure 21 - Installing Brick "S"**



# BRICK INSTALLATION

Continued

## STANDARD BRICK INSTALLATION FOR MODEL (V)GM42

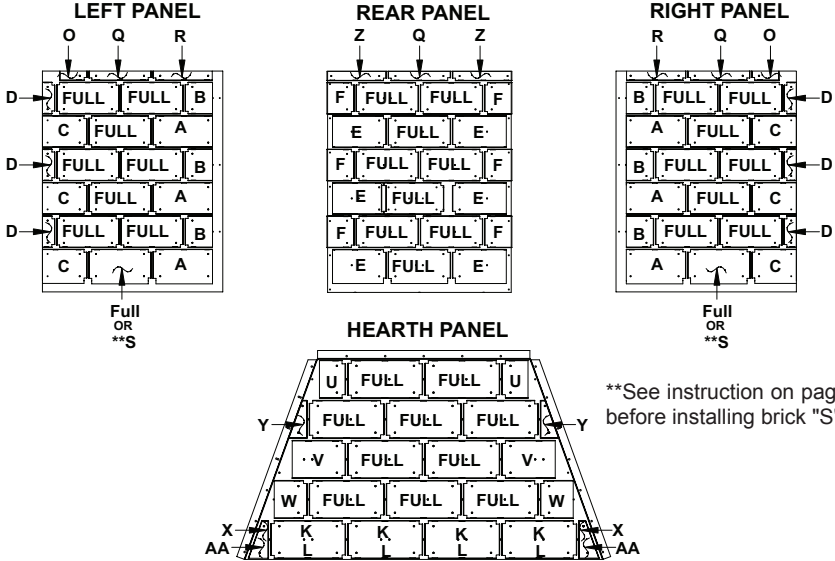

## HERRINGBONE BRICK INSTALLATION FOR MODEL (V)GM42H

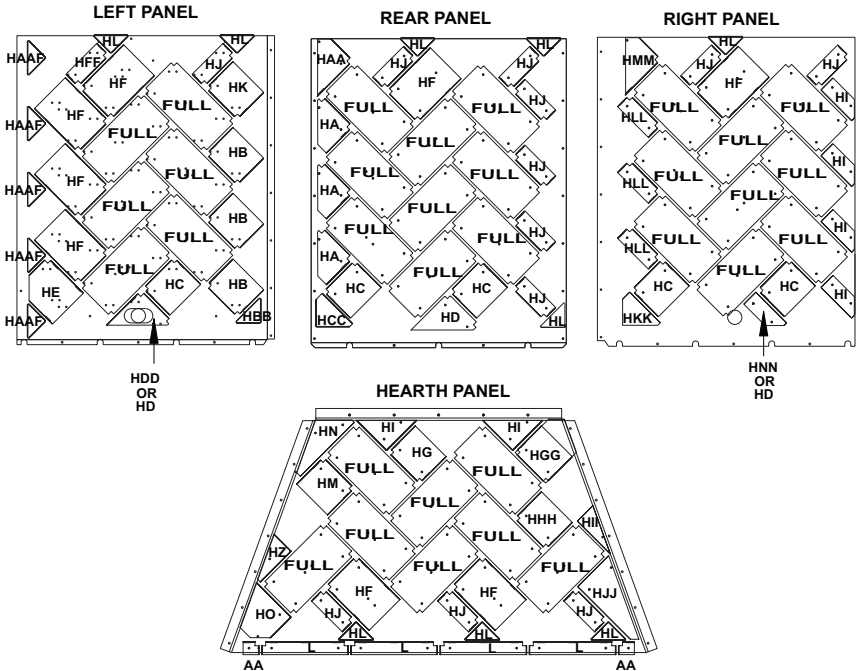



# BRICK INSTALLATION

Continued

## STANDARD BRICK INSTALLATION FOR MODEL (V)GM50

LEFT PANEL

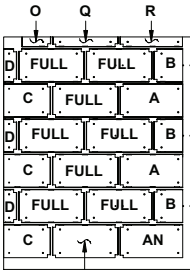

REAR PANEL

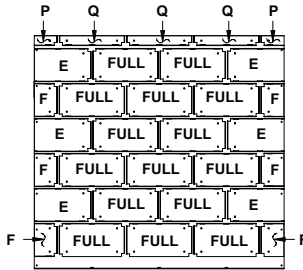

RIGHT PANEL

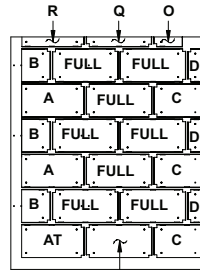

HEARTH PANEL

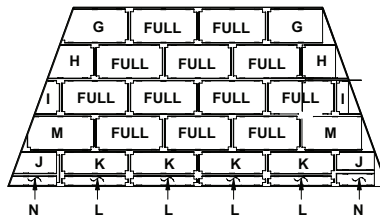

\*\*See instruction on page 14 before installing brick "S"

## HERRINGBONE BRICK INSTALLATION FOR MODEL (V)GM50H

LEFT PANEL

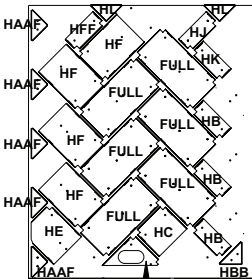

HDD  
OR  
HD

REAR PANEL

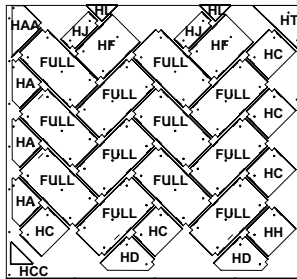

RIGHT PANEL

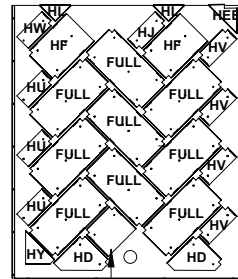

HX  
OR  
HC

HEARTH PANEL

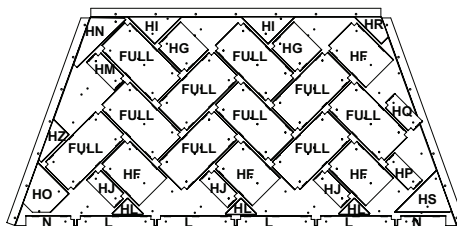

# BRICK INSTALLATION

*Continued*

## STANDARD BRICK MATRIX - (V)GM36

STANDARD BRICK MATRIX FOR MODEL (V)GM36																	
BRICK MATRIX	Full	A	B	C	D	E	F	G	H	I	J	K	L	M	N	O	P
Box #1 Hearth-36	8	-	-	-	-	-	-	2	2	2	-	-	3	2	-	-	-
Box #2 Rear-36	9	-	-	6	6	-	-	-	-	-	-	-	-	-	-	-	-
Box #3 Left or Right-36	5	-	-	-	-	-	-	-	-	-	-	-	-	-	-	-	1
Box #4 Left or Right-36	5	-	-	-	-	-	-	-	-	-	-	-	-	-	-	-	1
<b>TOTAL</b>	<b>27</b>	<b>0</b>	<b>0</b>	<b>6</b>	<b>6</b>	<b>0</b>	<b>0</b>	<b>2</b>	<b>2</b>	<b>2</b>	<b>0</b>	<b>0</b>	<b>3</b>	<b>2</b>	<b>0</b>	<b>0</b>	<b>2</b>

STANDARD BRICK MATRIX FOR MODEL (V)GM36 (Continued)														
BRICK MATRIX	Q	R	S	T	U	V	W	X	Y	Z	AA	AB	AC	AD
Box #1 Hearth-36	-	-	-	-	-	-	-	-	-	-	-	2	-	-
Box #2 Rear-36	2	-	-	-	-	-	-	-	-	-	-	-	-	-
Box #3 Left or Right-36	1	-	-	-	-	-	-	-	-	-	-	-	3	1
Box #4 Left or Right-36	1	-	-	-	-	-	-	-	-	-	-	-	3	1
<b>TOTAL</b>	<b>4</b>	<b>0</b>	<b>0</b>	<b>0</b>	<b>0</b>	<b>0</b>	<b>0</b>	<b>0</b>	<b>0</b>	<b>0</b>	<b>0</b>	<b>2</b>	<b>6</b>	<b>2</b>

STANDARD BRICK MATRIX FOR MODEL (V)GM36 (Continued)						
BRICK MATRIX	AE	AF	AG	AH	AI	TOTAL
Box #1 Hearth-36	-	-	-	-	-	21
Box #2 Rear-36	-	-	-	-	2	25
Box #3 Left or Right-36	3	3	3	1	-	21
Box #4 Left or Right-36	3	3	3	1	-	21
<b>TOTAL</b>	<b>6</b>	<b>6</b>	<b>6</b>	<b>2</b>	<b>2</b>	<b>88</b>

## HERRINGBONE BRICK MATRIX - (V)GM36H

HERRINGBONE BRICK MATRIX FOR MODEL (V)GM36H											
BRICK MATRIX	Full	HC	HD	HE	HF	HJ	HL	HOO	HPP	HQQ	HRR
Box #1 Hearth-36	4	-	-	-	3	2	3	1	1	1	1
Box #2 Rear-36	6	1	2	-	1	1	7	-	-	-	-
Box #3 Left-36	6	1	1	-	1	5	3	-	-	-	-
Box #4 Right-36	3	-	1	1	4	1	1	-	-	-	-
<b>TOTAL</b>	<b>19</b>	<b>2</b>	<b>4</b>	<b>1</b>	<b>9</b>	<b>12</b>	<b>14</b>	<b>1</b>	<b>1</b>	<b>1</b>	<b>1</b>

HERRINGBONE BRICK MATRIX FOR MODEL (V)GM36H (Continued)											
BRICK MATRIX	HSS	HTT	HUU	HVV	HWW	HXX	HYY	HZZ	HAAA	HAAB	HV
Box #1 Hearth-36	-	-	-	-	-	-	-	-	-	-	-
Box #2 Rear-36	3	1	1	-	-	-	-	-	-	-	3
Box #3 Left-36	-	-	-	-	-	-	3	1	1	1	-
Box #4 Right-36	-	-	-	3	1	1	-	-	-	1	-
<b>TOTAL</b>	<b>3</b>	<b>1</b>	<b>1</b>	<b>3</b>	<b>1</b>	<b>1</b>	<b>3</b>	<b>1</b>	<b>1</b>	<b>2</b>	<b>-</b>

HERRINGBONE BRICK MATRIX FOR MODEL (V)GM36H (Continued)									
BRICK MATRIX	HAAC	HAAD	HAAE	HAAF	HAAG	HAAH	AB	L	TOTAL
Box #1 Hearth-36	-	2	1	-	-	-	2	3	24
Box #2 Rear-36	1	-	-	-	-	-	-	-	27
Box #3 Left-36	-	-	-	-	-	-	-	-	23
Box #4 Right-36	-	-	-	3	2	4	-	-	26
<b>TOTAL</b>	<b>1</b>	<b>2</b>	<b>1</b>	<b>3</b>	<b>2</b>	<b>4</b>	<b>2</b>	<b>3</b>	<b>100</b>

# BRICK INSTALLATION

*Continued*

## STANDARD BRICK MATRIX - (V)GM42

STANDARD BRICK MATRIX FOR MODEL (V)GM42																	
BRICK MATRIX	Full	A	B	C	D	E	F	G	H	I	J	K	L	M	N	O	P
Box #1 Hearth-42	10	-	-	-	-	-	-	-	-	-	-	4	4	-	-	-	-
Box #2 Rear-42	9	-	-	-	-	6	6	-	-	-	-	-	-	-	-	-	-
Box #3 Left or Right-42	9	3	3	3	3	-	-	-	-	-	-	-	-	-	-	1	-
Box #4 Left or Right-42	9	3	3	3	3	-	-	-	-	-	-	-	-	-	-	1	-
<b>TOTAL</b>	<b>37</b>	<b>6</b>	<b>6</b>	<b>6</b>	<b>6</b>	<b>6</b>	<b>6</b>	<b>0</b>	<b>0</b>	<b>0</b>	<b>0</b>	<b>4</b>	<b>4</b>	<b>0</b>	<b>0</b>	<b>2</b>	<b>0</b>

STANDARD BRICK MATRIX FOR MODEL (V)GM42 (Continued)																
BRICK MATRIX	Q	R	S	T	U	V	W	X	Y	Z	AA	AB	AC	AD	AE	AF
Box #1 Hearth-42	-	-	-	-	2	2	2	2	2	-	2	-	-	-	-	-
Box #2 Rear-42	1	-	-	-	-	-	-	-	-	2	-	-	-	-	-	-
Box #3 Left or Right-42	1	1	1	-	-	-	-	-	-	-	-	-	-	-	-	-
Box #4 Left or Right-42	1	1	1	-	-	-	-	-	-	-	-	-	-	-	-	-
<b>TOTAL</b>	<b>3</b>	<b>2</b>	<b>2</b>	<b>0</b>	<b>2</b>	<b>2</b>	<b>2</b>	<b>2</b>	<b>2</b>	<b>2</b>	<b>2</b>	<b>0</b>	<b>0</b>	<b>0</b>	<b>0</b>	<b>0</b>

STANDARD BRICK MATRIX FOR MODEL (V)GM42 (Continued)						
BRICK MATRIX	AE	AF	AG	AH	AI	TOTAL
Box #1 Hearth-42	-	-	-	-	-	30
Box #2 Rear-42	-	-	-	-	-	24
Box #3 Left or Right-42	-	-	-	-	-	25
Box #4 Left or Right-42	-	-	-	-	-	25
<b>TOTAL</b>	<b>0</b>	<b>0</b>	<b>0</b>	<b>0</b>	<b>0</b>	<b>104</b>

## HERRINGBONE BRICK MATRIX - (V)GM42H

HERRINGBONE BRICK MATRIX FOR MODEL (V)GM42H														
BRICK MATRIX	Full	HA	HB	HC	HD	HE	HF	HG	HI	HJ	HK	HL	HM	HN
Box #1 Hearth-42	8	-	-	-	-	-	2	1	2	3	-	3	1	1
Box #2 Rear-42	9	3	-	2	1	-	1	-	-	6	-	3	-	-
Box #3 Left-42	6	-	3	1	1	1	4	-	-	1	1	2	-	-
Box #4 Right-42	9	-	-	2	1	-	1	-	4	2	-	1	-	-
<b>TOTAL</b>	<b>32</b>	<b>3</b>	<b>3</b>	<b>5</b>	<b>3</b>	<b>1</b>	<b>8</b>	<b>1</b>	<b>6</b>	<b>12</b>	<b>1</b>	<b>9</b>	<b>1</b>	<b>1</b>

HERRINGBONE BRICK MATRIX FOR MODEL (V)GM42H (Continued)													
BRICK MATRIX	HO	HZ	HAA	HBB	HCC	HDD	HEE	HFF	HGG	HHH	HII	HJJ	HKK
Box #1 Hearth-42	1	1	-	-	-	-	-	-	1	1	1	1	-
Box #2 Rear-42	-	-	1	-	1	-	-	-	-	-	-	-	-
Box #3 Left-42	-	-	-	1	-	1	-	1	-	-	-	-	-
Box #4 Right-42	-	-	-	-	-	-	-	-	-	-	-	-	1
<b>TOTAL</b>	<b>1</b>	<b>1</b>	<b>1</b>	<b>1</b>	<b>1</b>	<b>1</b>	<b>0</b>	<b>1</b>	<b>1</b>	<b>1</b>	<b>1</b>	<b>1</b>	<b>1</b>

HERRINGBONE BRICK MATRIX FOR MODEL (V)GM42H (Continued)							
BRICK MATRIX	HLL	HMM	HNN	HAAF	L	AA	TOTAL
Box #1 Hearth-42	-	-	-	-	4	2	33
Box #2 Rear-42	-	-	-	-	-	-	27
Box #3 Left-42	-	-	-	5	-	-	28
Box #4 Right-42	3	1	1	-	-	-	26
<b>TOTAL</b>	<b>3</b>	<b>1</b>	<b>1</b>	<b>5</b>	<b>4</b>	<b>2</b>	<b>114</b>

# BRICK INSTALLATION

*Continued*

## STANDARD BRICK MATRIX - (V)GM50

STANDARD BRICK MATRIX FOR MODEL (V)GM50																	
BRICK MATRIX	Full	A	B	C	D	E	F	G	H	I	J	K	L	M	N	O	P
Box #1 Hearth-50	12	-	-	-	-	-	-	2	2	2	2	4	4	2	2	-	-
Box #2 Rear-50	15	-	-	-	-	6	6	-	-	-	-	-	-	-	-	-	2
Box #3 Left or Right-50	9	3	3	3	3	-	-	-	-	-	-	-	-	-	-	1	-
Box #4 Left or Right-50	9	3	3	3	3	-	-	-	-	-	-	-	-	-	-	1	-
<b>TOTAL</b>	<b>45</b>	<b>6</b>	<b>6</b>	<b>6</b>	<b>6</b>	<b>6</b>	<b>6</b>	<b>2</b>	<b>2</b>	<b>2</b>	<b>2</b>	<b>4</b>	<b>4</b>	<b>2</b>	<b>2</b>	<b>2</b>	<b>2</b>

STANDARD BRICK MATRIX FOR MODEL (V)GM50 (Continued)														
BRICK MATRIX	Q	R	S	T	U	V	W	X	Y	Z	AA	AB	AC	AD
Box #1 Hearth-50	-	-	-	-	-	-	-	-	-	-	-	-	-	-
Box #2 Rear-50	3	-	-	-	-	-	-	-	-	-	-	-	-	-
Box #3 Left or Right-50	1	1	-	-	-	-	-	-	-	-	-	-	-	-
Box #4 Left or Right-50	1	1	-	-	-	-	-	-	-	-	-	-	-	-
<b>TOTAL</b>	<b>5</b>	<b>2</b>	<b>0</b>	<b>0</b>	<b>0</b>	<b>0</b>	<b>0</b>	<b>0</b>	<b>0</b>	<b>0</b>	<b>0</b>	<b>0</b>	<b>0</b>	<b>0</b>

STANDARD BRICK MATRIX FOR MODEL (V)GM50 (Continued)						
BRICK MATRIX	AE	AF	AG	AH	AI	TOTAL
Box #1 Hearth-50	-	-	-	-	-	32
Box #2 Rear-50	-	-	-	-	-	32
Box #3 Left or Right-50	-	-	-	-	-	25
Box #4 Left or Right-50	-	-	-	-	-	25
<b>TOTAL</b>	<b>0</b>	<b>0</b>	<b>0</b>	<b>0</b>	<b>0</b>	<b>114</b>

## HERRINGBONE BRICK MATRIX - (V)GM50H

HERRINGBONE BRICK MATRIX FOR MODEL (V)GM50H														
BRICK MATRIX	Full	HA	HB	HC	HD	HE	HF	HG	HH	HI	HJ	HK	HL	HM
Box #1 Hearth-50	10	-	-	-	-	-	4	2	-	2	3	-	3	1
Box #2 Rear-50	12	3	-	5	2	-	2	-	1	-	2	-	2	-
Box #3 Left-50	6	-	3	1	1	1	4	-	-	-	1	1	2	-
Box #4 Right-50	9	-	-	1	2	-	2	-	-	-	1	-	2	-
<b>TOTAL</b>	<b>37</b>	<b>3</b>	<b>3</b>	<b>7</b>	<b>5</b>	<b>1</b>	<b>12</b>	<b>2</b>	<b>1</b>	<b>2</b>	<b>7</b>	<b>1</b>	<b>9</b>	<b>1</b>

HERRINGBONE BRICK MATRIX FOR MODEL (V)GM50H (Continued)												
BRICK MATRIX	HN	HO	HP	HQ	HR	HS	HT	HU	HV	HW	HX	HY
Box #1 Hearth-50	1	1	1	1	1	1	1	-	-	-	-	-
Box #2 Rear-50	-	-	-	-	-	-	1	-	-	-	-	-
Box #3 Left-50	-	-	-	-	-	-	-	-	-	-	-	-
Box #4 Right-50	-	-	-	-	-	-	-	3	4	1	1	1
<b>TOTAL</b>	<b>1</b>	<b>1</b>	<b>1</b>	<b>1</b>	<b>1</b>	<b>1</b>	<b>1</b>	<b>3</b>	<b>4</b>	<b>1</b>	<b>1</b>	<b>1</b>

HERRINGBONE BRICK MATRIX FOR MODEL (V)GM50H (Continued)											
BRICK MATRIX	HZ	HAA	HBB	HCC	HDD	HEE	HFF	HAAF	L	N	TOTAL
Box #1 Hearth-50	1	-	-	-	-	-	-	-	4	2	38
Box #2 Rear-50	-	1	-	1	-	-	-	-	-	-	32
Box #3 Left-50	-	-	1	-	1	-	1	5	-	-	28
Box #4 Right-50	-	-	-	-	-	1	-	-	-	-	28
<b>TOTAL</b>	<b>1</b>	<b>1</b>	<b>1</b>	<b>1</b>	<b>1</b>	<b>1</b>	<b>1</b>	<b>5</b>	<b>4</b>	<b>1</b>	<b>126</b>

# BRICK INSTALLATION

*Continued*

## INSTALLING Z-SHAPED GRATE RETAINER BRACKET

Before grouting bricks, locate z-shaped grate retainer brackets on top of hearth bricks as shown in Figure 22. Position retainer brackets at 8 3/4" apart from center to center of notch.

Model	Distance Apart
GM36	3 1/4" Centers
GM42	4 1/4" Centers
GM50	8 3/4" Centers

See Chart for Grate Retainer Brackets Location

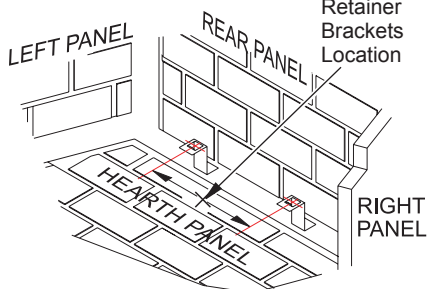

**Figure 22 - Installing Grate Retainer Bracket**

## GROUTING INSTRUCTIONS

Material provided:

2 - 9 lb. bags of cement

2 - 9 lb. bags of sand

Material required:

1 - Piping bag

1 - Joints striker

1 - Heavy duty mixing bucket

1 - Trowel

1. Moisten brick surface with a damp sponge or a spray bottle just prior to application. When bricks are wet, any excess grout mixture that might have gotten onto brick will easily wipe off.
2. In a heavy duty mixing bucket, pour seven (7) cups of water in first, then add in 4.5 lbs. (half of a bag) of sand and 4.5 lbs (half of a bag) of cement. Mix together well using a power drill with a mixing wand attachment.
3. The overall length of piping bag should be about 16". If bag is longer than 16", cut it down to size by removing end with larger opening. This will make bag easier to handle.

4. Put 2 to 3 cups of grout mixture into piping bag making sure smaller opening is downward and over a moist towel to avoid spilling. Place a wet towel over bucket making sure it is directly on surface of grout mixture. This will keep mixture moist and it will not dry out before use.
5. Begin grouting by first doing a "Filler Pass". This is done by filling the joint about 3/4 full with grout mixture. It is important to work with only 6 bricks at a time so grout doesn't have time to set up before striking.
6. Complete a "Finishing Pass" around 6 bricks you just put filler pass around. This is done by slowly filling in remainder of joint with a thick amount of grout mixture. Mixture should be a little higher than brick surface.
7. Using a trowel, remove excess grout mixture by moving trowel in the direction of the joint. Grout mixture in joint should now be flush with brick surface.
8. Using a Joint Striker, force grout mixture into joint and sweep back and forth until grout is smooth and round. If grout becomes too shallow, add more grout mixture with piping bag and strike again.
9. Continue procedure around each group of 6 bricks until an entire panel is finished.
10. Using trowel, scrape in direction of joints to remove any grout that may have collected around bricks during striking. If desired, take a moist sponge and lightly sweep over bricks to remove any grout that may have gotten on bricks. **DO NOT PRESS HARD OR RUB IN A CIRCULAR MOTION.** This will press grout into brick and turn brick a different color.

**Allow 72 hours before operating fireplace.**



**Figure 23 - Grouting Brick**

# GLASS DOOR INSTALLATION

**IMPORTANT:** Install glass door frame before installing glass door.

## DOOR MODELS BDM36E/G/C, BDM42E/G/C AND BDM50E/G/C

### Assembly

Insert L-shaped gussets starting at left top portion of door frame. Gusset holes should align with screw holes on frame. Secure using flat head screws.

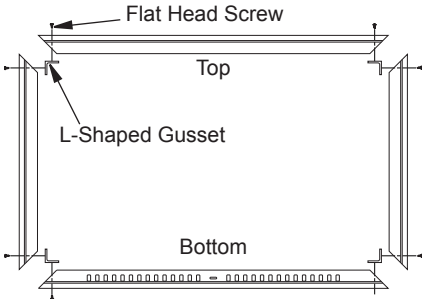

Figure 24 - Assembling Door Frame

### Installation

To install glass door frame, construct an opening (see table) on front face of fireplace. Insert door frame into face opening and tighten screws (see Figure 25).

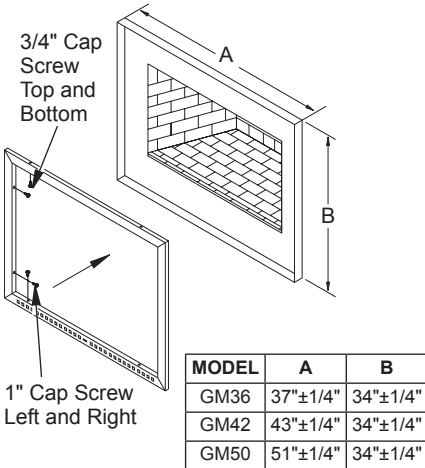

Figure 25 - Installing Door Frame

## DOOR FRAME MODELS BDMO36E/G/C, BDMO42E/G/C AND BDMO50E/G/C

### Installation

1. Remove screws from smoke shelf (see Figure 26).
2. Mount top door frame and secure with screws provided (see Figure 26).
3. Place bottom door frame on top of ash lip at front of fireplace (see Figure 27).
4. Secure bottom door frame to brick with two hex screws provided as shown in Figure 27 using a 7/16" open end or adjustable wrench.

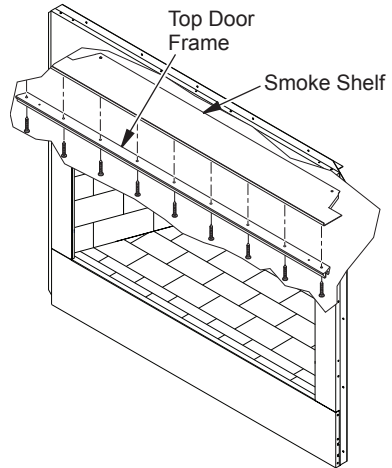

Figure 26 - Installing Top Door Frame

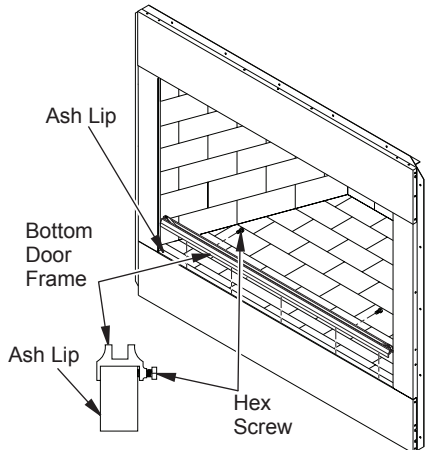

Figure 27 - Installing Bottom Door Frame

# GLASS DOOR INSTALLATION

*Continued*

## INSTALLING GLASS DOORS

Spring clips have been installed but some adjustments may be needed. Install doors using the following steps:

1. With bifold doors completely folded, insert bottom pivot pin into pivot hole located near bottom corner of front face opening and swing door to vertical position making sure top pins slide into door track. Door is installed when top door pin snaps into spring clip.

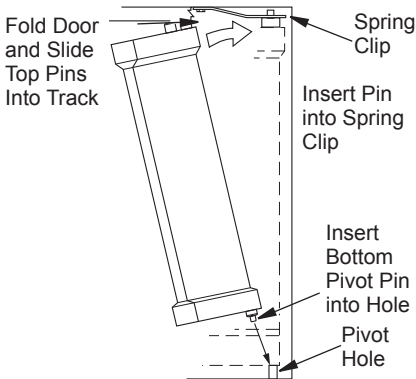

**Figure 28 - Installing Bifold Doors**

2. Repeat step 1 for remaining door.

If you find doors do not close properly or do not appear level or straight, proceed with section on door adjustment,

## DOOR ADJUSTMENT

Remove doors and slightly loosen lower pivot clips and upper spring clips. Replace doors and fully close them. Use 1/8" shims (any material) to level doors. Once proper setting is achieved, carefully open doors enough so that you can access spring clips with a phillips screwdriver. Tighten screws. See Figure 29.

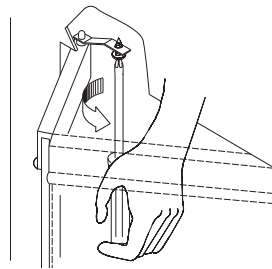

**Figure 29 - Adjusting Bi-Fold Doors**

## OPERATION AND MAINTENANCE GUIDELINES

### GLASS DOORS

Glass doors are optional with this fireplace. When fireplace is in operation, doors must be fully opened or fully closed position only or a fire hazard may be created (see Figure 30).

A fireplace equipped with glass doors operates much differently than a fireplace with an open front. A fireplace with glass doors has a limited amount of air for combustion.

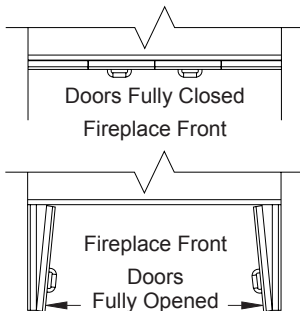

**Figure 30 - Bi-Fold Glass Doors**

Excessive heat within the fireplace can result if too large a fire is built or if combustion air gate is not completely open. The following tips should be followed to assure that both fireplace and glass door retain their beauty and function properly. Both flue damper and glass doors must be fully opened before starting fire. This will provide sufficient combustion air and maintain safe temperatures in firebox.

**IMPORTANT:** Glass must be allowed to warm slowly and evenly. Tempered glass will withstand a gradual temperature rise to 550° F, which is more than a normal fire will generate. Such materials as pitch/wax laden logs, very dry mill end lumber and large amounts of paper or cardboard boxes can create an excessively hot fire and should not be burned in this fireplace. Always keep fire back from doors and never allow flames to contact glass.

# OPERATION AND MAINTENANCE GUIDELINES

Continued

**⚠ WARNING:** Fireplaces equipped with glass doors should be operated only with doors fully opened or doors fully closed. Doors, if left partly open, may draw gas and flame out of the fireplace opening creating risks of both fire and smoke.

**⚠ WARNING:** Risk of fire! Replace grate with DESA Heating, LLC model 109496-03 GM36, 109496-02 GM42, 109496-01 GM50 grate only. This grate has been designed to keep the operation of your fireplace safe and efficient.

## Cleaning Glass

Clean glass with any commercial glass cleaner or soap and water. Do not use any abrasive material to clean glass. Do not clean glass with any cool water if glass is still hot from fire and smoke.

A gas line or gas log lighter may be installed for the purpose of installing a vented or vent-free decorative gas appliance incorporating an automatic shutoff device and complying with the *Standard for Decorative Gas Appliances for Installation in Vented Fireplaces, ANSI Z21.60* or *American Gas Association draft requirements for Gas Fired Log Lighters for Wood Burning Fireplaces, Draft NO. 4* dated August, 1993.

If you wish to install an unvented (vent-free) gas log set, only unvented gas log sets which have been found to comply with the standard for unvented room heaters, ANSI Z21.11.2 are to be installed in this fireplace.

## OUTSIDE AIR AND DAMPER HANDLE OPERATION

Damper handle, which opens and closes damper blade, is located in upper front face of fireplace. Pushing handle forward and up through keyway slot will free damper blade to automatically open. Pushing handle forward and down will lock damper blade closed (see Figure 31).

Outside air kit lever is located at left and right hand sides of fireplace (see Figure 32). Lifting lever up will free the outside air door to open. Pulling lever down will lock door.

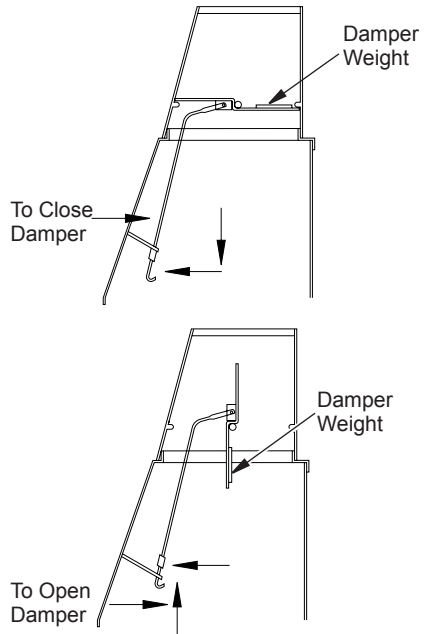

Figure 31 - Operating Damper Handle

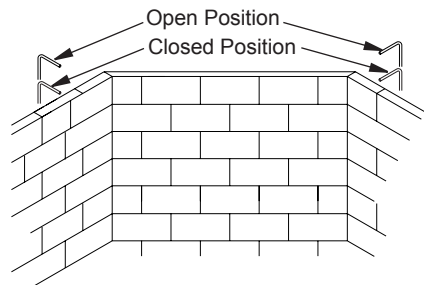
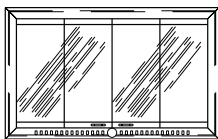

Figure 32 - Outside Air Kit Lever



## REPLACEMENT AND ACCESSORY PARTS



### BI-FOLD GLASS MASONRY DOOR

BDM36E - 36" Ebony  
BDM36G - 36" Pewter  
BDM36C - 36" Oiled Bronze  
BDM42E - 42" Ebony  
BDM42G - 42" Pewter  
BDM42C - 42" Oiled Bronze  
BDM50E - 50" Ebony  
BDM50G - 50" Pewter  
BDM50C - 50" Oiled Bronze

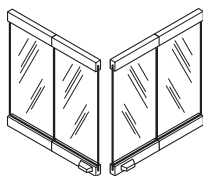

BDMO36E - 36" Ebony  
BDMO36G - 36" Pewter  
BDMO36C - 36" Oiled Bronze  
BDMO42E - 42" Ebony  
BDMO42G - 42" Pewter  
BDMO42C - 42" Oiled Bronze  
BDMO50E - 50" Ebony  
BDMO50G - 50" Pewter  
BDMO50C - 50" Oiled Bronze

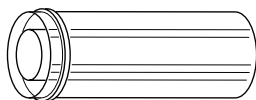

DOUBLE WALL PIPE - 12-12DM,  
18-12DM, 24-12DM, 36-12DM, 48-12DM,  
12-12HT, 18-12HT, 24-12HT, 36-12HT and  
48-12HT

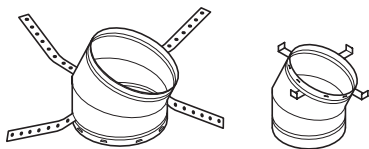

30° OFFSET AND RETURN  
30E-12DM and 30E-12HT

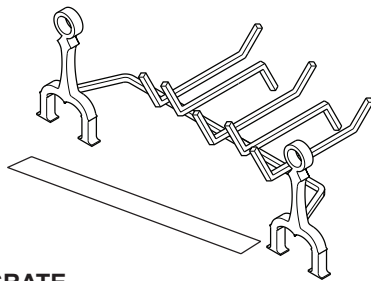

### GRATE

109496-03 - Model GM36  
109496-02 - Model GM42  
109496-01 - Model GM50

### EMBER PROTECTOR - EP36

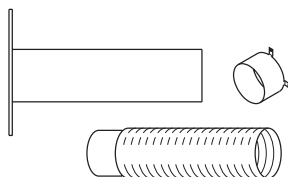

### OPTIONAL OUTSIDE AIR KIT FOR FLOOR INSTALLATION - AK4F

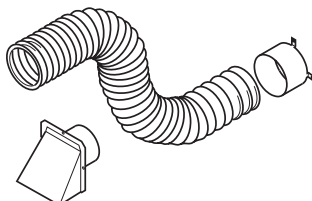

### OPTIONAL OUTSIDE AIR KIT FOR SIDEWALL INSTALLATION - AK4



### STORM COLLAR - SC2-1

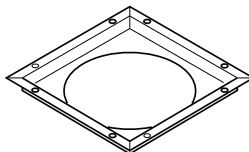

FIRESTOP SPACER - FS-10  
(1100EFS-10DM FOR MODEL GM36)

---

## REPLACEMENT AND ACCESSORY PARTS

*Continued*

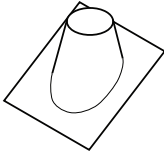

### ROOF FLASHING

V6F-10DM - 0 to 6/12 Pitch

V12F-10DM - 6/12 to 12/12 Pitch

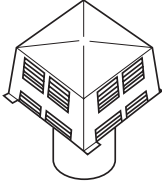

### SQUARE CHASE-TOP TERMINATION - STL-12D

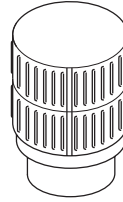

### ROUND TOP TERMINATIONS RLT-12D AND RLT-12HT

### TECHNICAL SERVICE

You may have further questions about installation, operation, or troubleshooting. If so, contact DESA Heating, LLC at 1-866-672-6040. When calling please have your model and serial numbers of your heater ready.

You can also visit DESA Heating, LLC's web site at [www.desatech.com](http://www.desatech.com).





DESA Heating, LLC  
2701 Industrial Drive  
P.O. Box 90004  
Bowling Green, KY 42102-9004  
[www.desatech.com](http://www.desatech.com)  
1-800-672-6040



112435 01  
NOT A UPC

112435-01  
Rev. R  
07/07