

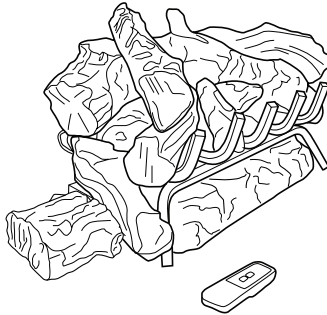

The new name in flame

VENTED DECORATIVE GAS LOG APPLIANCE OWNER'S OPERATION AND INSTALLATION MANUAL



MODELS
VTD-18N-TKA,
VTD-18P-TKA,
VTD-24N-TKA AND
VTD-24P-TKA



These logs are approved by the manufacturer for installation in listed indoor and outdoor solid fuel burning fireplaces. See warranty for additional information.

⚠ WARNING: If the information in this manual is not followed exactly, a fire or explosion may result causing property damage, personal injury or loss of life.

- Do not store or use gasoline or other flammable vapors and liquids in the vicinity of this or any other appliance.
- **WHAT TO DO IF YOU SMELL GAS**
 - Do not try to light any appliance.
 - Do not touch any electrical switch; do not use any phone in your building.
 - Immediately call your gas supplier from a neighbor's phone. Follow the gas supplier's instructions.
 - If you cannot reach your gas supplier, call the fire department.
- Installation and service must be performed by a qualified installer, service agency or the gas supplier.

INSTALLER: Leave this manual with the appliance
CONSUMER: Retain this manual for future reference.

TABLE OF CONTENTS

Safety	2	Specifications	17
Local Codes.....	4	Service Hints	17
Unpacking.....	4	Technical Service.....	17
Product Identification.....	5	Wiring Diagram.....	18
Installation	5	Replacement Parts.....	19
Operation.....	10	Accessories	19
Cleaning and Maintenance.....	12	Parts	20
Inspecting Burners.....	13	Warranty.....	Back Cover
Troubleshooting.....	14		

SAFETY

⚠ WARNING: Improper installation, adjustment, alteration, service or maintenance can cause injury or property damage. Refer to this manual for correct installation and operational procedures. For assistance or additional information consult a qualified installer, service agency or the gas supplier.

This appliance may be installed in an aftermarket,* permanently located, manufactured (mobile) home, where not prohibited by local codes.

This appliance is only for use with type of gas indicated on rating plate. This appliance is not convertible for use with other gases.

* Aftermarket: Completion of sale, not for purpose of resale, from the manufacturer

⚠ WARNING: This appliance is for installation only in a solid-fuel burning masonry or UL127 factory-built fireplace, constructed of noncombustible material and connected to a working flue. (See page 6 for minimum flue opening.)

⚠ WARNING: This is a gas-fired heater. It uses air (oxygen) from the room in which it is installed. Provisions for adequate combustion and ventilation air must be provided. Refer to the *National Fuel Gas Codes, ANSI Z233.1/ NFPA 54, Air for Combustion and Ventilation*.

State of Massachusetts: Installation must be made by a licensed plumber or gas fitter in the Commonwealth of Massachusetts.

IMPORTANT: Read this owner's manual carefully and completely before trying to assemble, operate or service this log set. Improper use of this log set can cause serious injury or death from burns, fire, explosion, electrical shock and carbon monoxide poisoning.

⚠ WARNING: This product contains and/or generates chemicals known to the State of California to cause cancer or birth defects or other reproductive harm.

⚠ WARNING: Keep flue open when operating unit.

SAFETY

Continued

⚠ DANGER: Carbon monoxide poisoning may lead to death!

Carbon Monoxide Poisoning: Early signs of carbon monoxide poisoning resemble the flu, with headaches, dizziness or nausea. If you have these signs, log set may not be working properly. **Get fresh air at once!** Have log set serviced. Some people are more affected by carbon monoxide than others. These include pregnant women, people with heart or lung disease or anemia, those under the influence of alcohol and those at high altitudes.

Natural and Propane/LP Gas: Natural and propane/LP gases are odorless. An odor-making agent is added to the gas. The odor helps you detect a gas leak. However, the odor added to the gas can fade. Gas may be present even though no odor exists.

Make certain you read and understand all warnings. Keep this manual for reference. It is your guide to safe and proper operation of this log set.

⚠ WARNING: Any change to this log set or its controls can be dangerous.

⚠ WARNING: Do not use a blower insert, heat exchanger insert or other accessory not approved for use with this appliance.

⚠ WARNING: Do not allow fans to blow directly into fireplace. Avoid any drafts that alter burner flame patterns.

Due to high temperatures, the appliance should be located out of traffic and away from furniture and draperies.

Do not place clothing or other flammable material on or near the appliance. Never place any objects on heater.

Log set becomes very hot when running. Keep children and adults away from hot surface to avoid burns or clothing ignition. Log set will remain hot for a time after shutdown. Allow surface to cool before touching.

Carefully supervise young children when they are in the room with log set. When using handheld remote accessory, keep selector switch in OFF position to prevent children from turning on burners with remote.

You must operate this appliance with a fireplace screen in place. Make sure fireplace screen is closed before running appliance.

Keep the appliance area clear and free from combustible materials, gasoline and other flammable vapors and liquids.

1. This appliance, as supplied, is only for use with type of gas indicated on rating plate.
2. If you smell gas
 - shut off gas supply
 - do not try to light any appliance
 - do not touch any electrical switch; do not use any phone in your building
 - immediately call your gas supplier from a neighbor's phone. Follow gas supplier's instructions
 - if you cannot reach your gas supplier, call the fire department
3. Never install log set
 - in a recreational vehicle
 - where curtains, furniture, clothing or other flammable objects are less than 42" from front, top or sides of log set
 - in windy or drafty areas

SAFETY

Continued

- Before installing in a solid fuel burning fireplace, chimney flue and firebox must be cleaned of soot, creosote, ashes and loose paint by a qualified chimney cleaner. Creosote will ignite if highly heated. Inspect chimney flue for damage. If damaged, repair flue before operating appliance.
- You must operate this log set with fireplace screen in place and fully closed. Any glass doors must be open during operation.
- This log set is designed to be smokeless. If logs ever appear to smoke, turn off appliance and call a qualified service person.
Note: During initial operation, slight smoking could occur due to log curing and burning of manufacturing residues. You may wish to add more ventilation by opening a window.
- To reduce creation of soot, follow instructions in Cleaning and Maintenance, page 12.
- Installation and provisions for combustion and ventilation air must conform with the *National Fuel Gas Codes, ANSI Z223.1/NFPA 54, Air for combustion and Ventilation*.
- Do not run log set
 - where flammable liquids or vapors are used or stored
 - under dusty conditions
- Do not burn solid fuel in fireplace after installing log set. Do not use this log set to cook food or burn paper or other objects.
- Do not use appliance if any part has been exposed to or under water. Immediately call a qualified service technician to inspect room heater and to replace any part of control system and any gas control which has been under water.
- Turn log set off and let cool before servicing, installing or repairing. Only a qualified service person should install, service or repair log set.
- Provide adequate clearances around air openings.
- The receiver on this unit (see Figure 12, page 9) has an antenna that has been attached with adhesive. DO NOT remove or alter placement of this antenna as this will short circuit receiver.

LOCAL CODES

Install and use log set with care. Follow all local codes. In the absence of local codes, use the latest edition of the *National Fuel Gas Code ANSI Z223.1/NFPA 54**

*Available from:

American National Standards Institute, Inc.
1430 Broadway
New York, NY 10018
National Fire Protection Association, Inc.
Battery March Park
Quincy, MA 02269

UNPACKING

CAUTION: Do not remove data plates from grate assembly. Data plates contain important warranty and safety information.

- Remove contents from side compartments (see Figure 1).
- Remove log set by lifting tray handles. Set tray on floor.
- Remove log set from tray by cutting zip ties.
- Check heater for any shipping damage. If heater is damaged call DESA Heating, LLC at 1-866-672-6040 for replacement parts before returning to dealer.

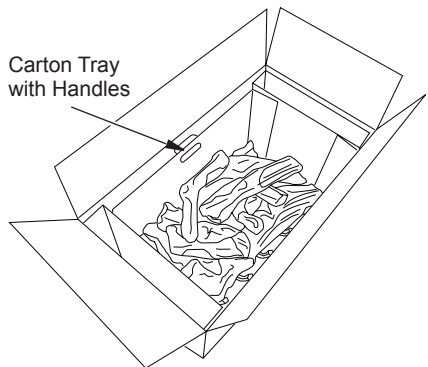

Figure 1 - Log Set in Packing Box

PRODUCT IDENTIFICATION

⚠ WARNING: Failure to position parts in accordance with these diagrams or failure to use only parts specifically approved with this appliance may result in property damage or personal injury.

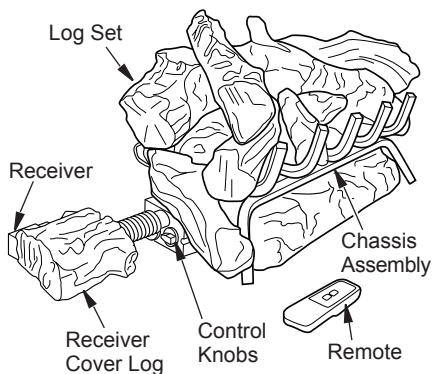

Figure 2 - Product Identification (Ramp Pan Burner)

INSTALLATION

⚠ WARNING: The Massachusetts State Board requires all installations be performed by a Licensed Plumber or Gas Fitter. Massachusetts state code requires all vent dampers be welded open or removed.

⚠ WARNING: A qualified service person must install this appliance. Follow all local codes.

⚠ WARNING: Before installing in a solid fuel burning fireplace, the chimney flue and firebox must be cleaned of soot, creosote, ashes and loose paint by a qualified chimney cleaner. Creosote will ignite if highly heated. A dirty chimney flue may create and distribute soot within the house. Inspect chimney flue for damage. If damaged, repair flue damper before operating appliance.

NOTICE: Installation, service and repair of this appliance must be performed by a qualified installer, service agency, company or gas supplier experienced with this type of gas appliance. Only factory authorized components listed in these instructions may be used in accordance with manufacturer's instructions and all codes and requirements of the authority having jurisdiction. Any modifications to or use of unauthorized components or accessory items will void manufacturer's warranty and may result in a hazardous condition.

INSTALLATION AND CLEARANCES

Figure 3 shows technical information regarding installation of your gas log set. Please make sure that all specifications shown are applicable before installation is attempted.

	SPECIFICATIONS (W.C.)		
	FUEL INLET PRESSURE		MANIFOLD PRESSURE
	Min.	Max.	
NG	7"	10.5"	3.5"
LP	11"	14"	10"

Figure 3 - Technical Information Chart

INSTALLATION

Continued

Flue Opening Specifications

Note: This vented appliance must be installed only in a solid-fuel burning fireplace constructed of noncombustible material.

The fireplace must include a flue and venting system with minimum openings shown in Figure 4.

LOG SIZING REQUIREMENTS					
Log Size	Minimum Firebox Size				Min. Flue Size
	Height	Depth	Front Width	Rear Width*	
18"	20"	14"	32"	22"	8"
24"	20"	14"	39"	25"	8"

* Measured at 14" depth.

Figure 4 - Sizes and Clearances

CHECK GAS TYPE

Use the correct gas type (natural or propane/LP) for your unit. If your gas supply is not correct, DO NOT install this gas log set. Call dealer where you bought the appliance for proper type of appliance.

⚠ WARNING: This appliance is equipped for either natural gas or propane/LP gas but not both. Gas type is indicated on the rating plate. Field conversion is not permitted.

VENTING SPECIFICATIONS FOR INSTALLATION

The fireplace chimney flue and vent must be drafting properly. To check vent for proper drafting, light a tightly rolled newspaper on one end and place it to inside front edge of fireplace. Observe smoke and be sure vent is properly drawing it up the chimney. If smoke spills out into room, extinguish flame and remove any obstruction until proper venting is achieved.

The chimney flue must remain open a minimum of 43 sq. inches of free air opening during operation of this log set. A multipurpose damper clamp is provided to fix damper in position.

For Massachusetts Residents Only: Installation of this vented gas log set in the Commonwealth of Massachusetts requires the damper be permanently removed or welded in the fully open position.

Minimum flue sizes shown in Figure 3, page 5, are based on a 6' chimney height using round pipe. Your minimum flue size will vary based on input rate and chimney height. Refer to the *National Fuel Gas Code ANSI Z223.1/NFPA 54, Section 6.6* for details.

INSTALLING DAMPER CLAMP

Secure damper stop clamp to edge of damper as shown in Figure 5. If for any reason this clamp doesn't work on your fireplace, another suitable clamp or permanent stop must be installed, or damper blade must be cut or removed.

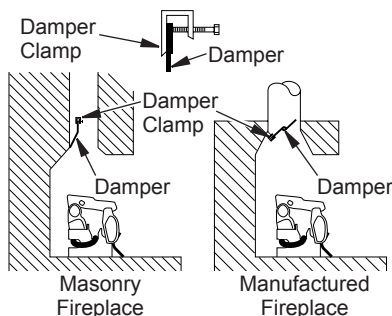

Figure 5 - Attaching Damper Clamp

INSTALLING APPLIANCE ASSEMBLY

⚠ WARNING: If installing in a sunken fireplace, special care is needed. You must raise fireplace floor to allow access to appliance controls. This will insure adequate air flow and guard against sooting. Raise fireplace floor with noncombustible material. Make sure material is secure.

⚠ CAUTION: Do not pick up appliance assembly by logs. This could damage unit. Only handle assembly by grates.

IMPORTANT: Make sure appliance is level. If unit is not level, unit will not work properly.

INSTALLATION

Continued

Installation Items Needed

- control cover kit (provided with appliance)
 - approved flexible gas hose and fittings (provided with appliance) (if allowed by local codes)
 - sealant (resistant to propane/LP gas, not provided)
1. Position appliance in fireplace.
 2. Connect to gas supply (see [Connecting to Gas Supply](#)).

Flexible Gas Hose with Regulator

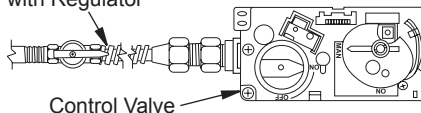

Figure 6 - Flexible Gas Hose and Gas Regulator

CONNECTING TO GAS SUPPLY

⚠ WARNING: This appliance requires 3/8" NPT National Pipe Thread) inlet connection to pressure regulator.

⚠ WARNING: A qualified service person must connect heater to gas supply. Follow all local codes.

⚠ CAUTION: Never connect propane/LP appliance directly to propane/LP supply. This unit requires an external regulator (not supplied). Install external regulator between unit and propane/LP supply.

⚠ WARNING: Never connect natural gas fireplace to private (non-utility) gas wells. This gas is commonly known as wellhead gas.

Installation Items Needed

Before installing log set, make sure you have items listed below.

- external regulator (supplied by installer)
- piping (check local codes)
- sealant (resistant to propane/LP gas)
- equipment shutoff valve*
- test gauge connection*
- sediment trap
- tee joint
- pipe wrench
- approved flexible gas line with gas connector (if allowed by local codes) (provided)

* A CSA design-certified equipment shutoff valve with 1/8" NPT tap is an acceptable alternative to test gauge connection. Purchase optional CSA design-certified equipment shutoff valve from your dealer.

For propane/LP units, installer must supply an external regulator. The external regulator will reduce incoming gas pressure. You must reduce incoming gas pressure to between 11" and 14" of water. If you do not reduce incoming gas pressure, regulator damage could occur. Install external regulator with vent pointing down as shown in Figure 7. Pointing vent down protects it from freezing rain or sleet.

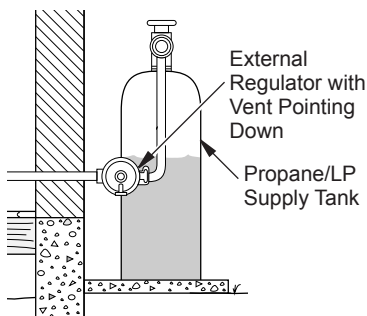

Figure 7 - External Regulator with Vent Pointing Down

INSTALLATION

Continued

⚠ CAUTION: Use only new, black iron or steel pipe. Internally-tinned copper tubing may be used in certain areas. Check your local codes. Use pipe of 1/2" diameter or greater to allow proper gas volume to heater. If pipe is too small, undue loss of volume will occur.

Installation must include an equipment shutoff valve, union and plugged 1/8" NPT tap. Locate NPT tap within reach for test gauge hook up. NPT tap must be upstream from log set (see Figure 8).

IMPORTANT: Install equipment shutoff valve in an accessible location. Equipment shutoff valve is for turning on or shutting off gas to appliance.

Apply pipe joint sealant lightly to male NPT threads. This will prevent excess sealant from going into pipe. Excess sealant in pipe could result in clogged heater valves.

⚠ WARNING: Use pipe joint sealant that is resistant to liquid petroleum (LP) gas.

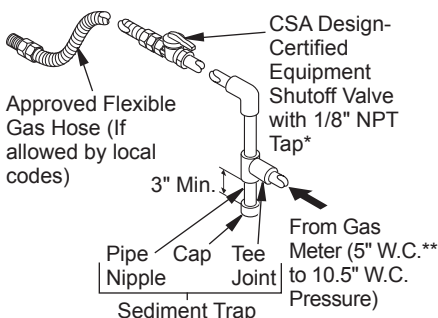

Figure 8 - Gas Connection

* Purchase the optional CSA design-certified shutoff valve from your dealer.

** Minimum inlet pressure for purpose of input adjustment.

We recommend that you install a sediment trap in supply line as shown in Figure 8. Locate sediment trap where it is within reach for cleaning. Install in piping system between fuel supply and appliance. Locate sediment trap where trapped matter is not likely to freeze. A sediment trap traps moisture and contaminants. This keeps them from going into heater controls. If sediment trap is not installed or is installed wrong, heater may not run properly.

⚠ CAUTION: Avoid damage to gas control. Hold gas control with wrench when connecting it to gas piping and/or fittings.

CHECKING GAS CONNECTIONS

⚠ WARNING: Test all gas piping and connections, internal and external to unit, for leaks after installing or servicing. Correct all leaks at once.

⚠ WARNING: Never use an open flame to check for a leak. Apply a noncorrosive leak detection fluid to all joints. Bubbles forming show a leak. Correct all leaks at once.

⚠ CAUTION: Make sure external regulator has been installed between propane/LP supply and appliance. See guidelines under Connecting to Gas Supply, page 7.

PRESSURE TESTING GAS SUPPLY PIPING SYSTEM

Test Pressures In Excess Of 1/2 PSIG (3.5 kPa)

1. Disconnect appliance with its appliance main gas valve (control valve) and equipment shutoff valve from gas supply piping system. Pressures in excess of 1/2 psig will damage appliance regulator.
2. Cap off open end of gas pipe where equipment shutoff valve was connected.

INSTALLATION

Continued

3. Pressurize supply piping system by either opening propane/LP supply tank valve for propane/LP gas or opening main gas valve located on or near gas meter for natural gas, or using compressed air.
4. Check all joints of gas supply piping system. Apply noncorrosive leak detection fluid to all joints. Bubbles forming show a leak.
5. Correct all leaks at once.
6. Reconnect appliance and equipment shutoff valve to gas supply. Check reconnected fittings for leaks.

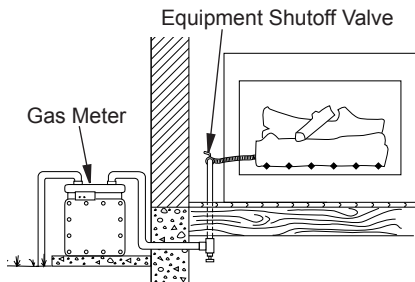

**Figure 11 - Checking Gas Joints
(Natural Gas Only)**

Test Pressures Equal To or Less Than 1/2 PSIG (3.5 kPa)

1. Close equipment shutoff valve (see Figure 9).
2. Pressurize supply piping system by either opening propane/LP supply tank valve for propane/LP gas or opening main gas valve located on or near gas meter for natural gas, or using compressed air.
3. Check all joints from gas meter to equipment shutoff valve for natural gas or propane/LP supply to equipment shutoff valve for propane/LP (see Figures 10 and 11). Apply noncorrosive leak detection fluid to all joints. Bubbles forming show a leak.
4. Correct all leaks at once.

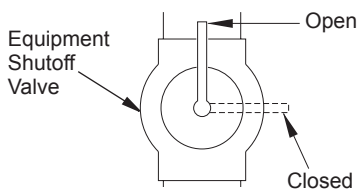
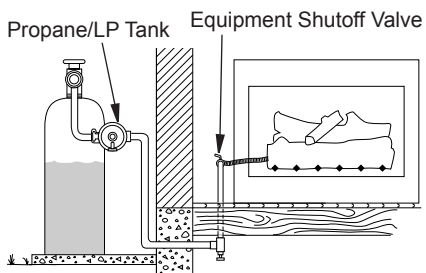

Figure 9 - Equipment Shutoff Valve



**Figure 10 - Checking Gas Joints
(Propane/LP Gas Only)**

PRESSURE TESTING APPLIANCE GAS CONNECTIONS

1. Open equipment shutoff valve (see Figure 9).
2. Open main gas valve located on or near gas meter for natural gas or open propane/LP supply tank valve.
3. Make sure control knob of appliance is in OFF position.
4. Check all joints from equipment shutoff valve to gas control (see Figures 10 and 11). Apply noncorrosive leak detection fluid to all joints. Bubbles forming show a leak.
5. Correct all leaks at once.
6. Light appliance (see *Operation*, page 10). Check all other internal joints for leaks.
7. Turn off appliance.

INSTALLING RECEIVER AND COVER LOG

1. Place receiver into position beside chassis in fireplace. Receiver should lay flat on floor of fireplace (see Figure 12).
2. Place receiver cover log over receiver. This will hide receiver from view (see Figure 12).

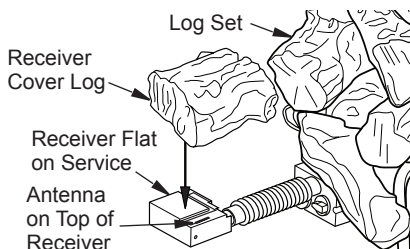

Figure 12 - Receiver and Cover Log

OPERATION

FOR YOUR SAFETY READ BEFORE LIGHTING

⚠ WARNING: Keep flue open when operating unit.

⚠ WARNING: If you do not follow these instructions exactly, a fire or explosion may result causing property damage, personal injury or loss of life.

- A. This appliance has a pilot which must be lighted by hand. When lighting pilot, follow these instructions exactly.
- B. **BEFORE LIGHTING** smell all around the appliance area for gas. Be sure to smell next to the floor because some gas is heavier than air and will settle on the floor.

WHAT TO DO IF YOU SMELL GAS

- Do not try to light any appliance.
 - Do not touch any electric switch; do not use any phone in your building.
 - Immediately call your gas supplier from a neighbor's phone. Follow the gas supplier's instructions.
 - If you cannot reach your gas supplier, call the fire department.
- C. Use only your hand to push in or turn the gas control knob. Never use tools. If knob will not push in or turn by hand, don't try to repair it, call a qualified service technician or gas supplier. Force or attempted repair may result in a fire or explosion.
 - D. Do not use this appliance if any part has been under water. Immediately call a qualified service technician to inspect the appliance and to replace any part of the control system and any gas control which has been under water.

REMOTE OPERATION

REMOTE LIGHTING INSTRUCTIONS





NOTICE: During initial operation of new appliance, metallic components may emit an odor as paint and assembly compounds are heated and cured. Be sure to provide adequate fresh air if odors are detected.

⚠ CAUTION: A mild gas flash within 10 seconds is normal during shutdown of this heater. Remain clear of hearth area for the entire shutdown process to avoid possible injury.

1. STOP! Read safety information, above.
2. Make sure equipment shutoff valve is fully open.
3. Turn motor knob clockwise  to OFF position.
4. Wait five (5) minutes to clear out any gas. Then smell for gas, including near the floor. If you smell gas, STOP! Follow "B" in safety information, above. If you don't smell gas, go to next step.

5. Make sure ON/OFF switch is in "-" (ON) position.

⚠ WARNING: Burner will come on automatically within one minute after pilot burner is lighted.

6. Press buttons  and  at the same time. A short acoustic signal confirms start sequence has begun. Further short acoustic signals (0.2 sec., 1 Hz) indicate ignition process until it is completed and main gas flows. If pilot is already lit, motor will turn on (max. flame height) while buttons are pressed down. If pilot does not light, see [Troubleshooting](#), page 14.
7. Press  to turn on main burner and increase flame height. Press  to decrease flame height and shut off main burner.

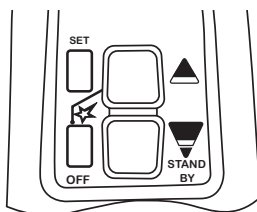

Figure 13 - Control Panel for Remote

OPERATION

Continued

REMOTE OPERATION

8. Short tapping of either button allows incremental change in flame height.
9. Press OFF button to switch off main gas and pilot gas.
10. To turn off burners only, press ▼ to decrease flame height and shut off main burner. Close equipment shutoff valve (see Figure 9, page 9).

FUNCTIONS OF REMOTE CONTROL

Battery

- After charged battery has been correctly installed, remote hand set is ready for operations.
- Remove battery if remote handset will not be used more than one year.

Changing Code

The control is radio frequency operated. A code (chosen from among 4,000 available codes) is preset for all valves, but can be changed if required (15 additional codes available). Change DIP switch position. (DIP switch is located inside hand held control at top of battery compartment.) Press receiver's reset button on bottom of receiver module until you hear a second (longer) signal. When pressing ▼ button on remote handset in the following 20 sec., receiver learns new code.

Shut Off Procedure

To save battery power; press ▼ to turn main gas to pilot gas. Press OFF button to shut off heater including pilot flame. Heater can be shut off with ON/OFF switch, thus disabling remote hand set.

Setting Display (°C/24h and °F/12h)

Press and hold OFF and ▼ until display changes from °F (and 12 hour clock) to °C (and 24 hour clock) or vice versa.

Setting Time

- After connecting battery or by simultaneously pressing ▲ and ▼ display will start to flash. You are in SET mode.
- From SET mode press ▲ to set hour and ▼ to set minute.
- Wait or press OFF to return to manual mode.

Battery Replacement

Remote handset battery needs to be changed when LED is dim. Battery life expectancy is 2 to 3 years. If 4 "AA" batteries are used in receiver, replacement is recommended at the beginning of heating season. Battery needs to be changed when acoustic error message appears during ignition (see [Identifying Error Signals from Receiver](#) on page 16).

TO TURN OFF GAS TO APPLIANCE

Press OFF button on remote control to switch off main gas and pilot gas.

MANUAL OPERATION

LIGHTING PROCEDURE

⚠ WARNING: Manual lighting must be performed by a qualified service person.

The system has a "MANUAL OVERRIDE" feature that allows you to light with a match.

Lighting with a Match

1. STOP! Read safety information, page 10.
2. Make sure equipment shutoff valve is fully open.

3. Turn motor knob clockwise  to OFF position.
4. Wait (5) minutes to clear any gas and then smell for gas around heater and near floor. If you smell gas, STOP! follow "B" on page 10. If you do not smell gas, go to next step.
5. Make sure ON/OFF switch is in "-" (ON) position.
6. With MAN knob on valve in MAN position, a metallic core is visible. (see Figure 14, page 12).
7. Push and hold down metal core fully by using a non-sharp object such as a pen. This lets pilot gas flow.

OPERATION

Continued

MANUAL OPERATION

- Light pilot burner with a match, (see Figure 15).
- Continue holding down metal core for about 10 seconds. Pilot should stay lit after releasing metal core. If not, repeat steps 1 thru 4, page 11.
- Turn MAN knob counterclockwise ↺ to ON position. This lets main gas flow.
- Turn Motor knob to adjust flame. Knob has a slipping clutch that allows manual flame height adjustment as well as adjustment to pilot gas.
- STOP! Read safety information, page 10.
- Make sure equipment shutoff valve is fully open.
- Turn motor knob clockwise ↻ to OFF position.
- Wait (5) minutes to clear any gas and then smell for gas around heater and near floor. If you smell gas, STOP! follow "B" on page 10.
- ON/OFF switch in "—" ON position.
- MAN-knob on valve is in MAN position (see Figure 14). When in MAN position you can see a metallic core.

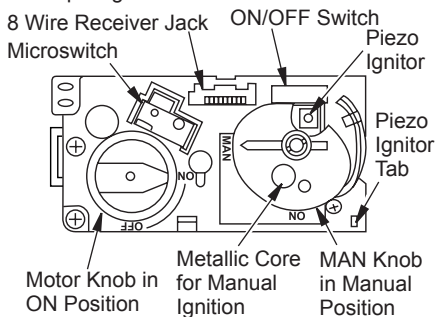

Figure 14 - Control Valve

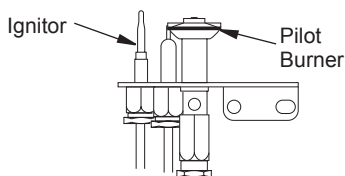

Figure 15 - Pilot

Lighting with Piezo Ignitor

- Disconnect ignitor cable from receiver and connect to Piezo Ignitor Tab (see Figure 14 and [Wiring Diagram](#) on page 18).

- Push and hold down metal core fully with a pen while pilot gas flows.
- Press and release piezo ignitor button until pilot lights.
- Continue holding down metal core for about 10 seconds and then release metal core. Pilot should stay lit. If not, repeat steps 1 through 4.
- Turn MAN knob counterclockwise ↺ to ON position. This lets main gas flow.
- Turn motor knob to adjust flame. Knob has a slipping clutch that allows manual flame height adjustment.
- To turn off burners only, press ▼ to decrease flame height and shut off main burner. Close equipment shutoff valve (see Figure 9, page 9).

TO TURN GAS OFF TO APPLIANCE

Press OFF button on remote control to switch off main gas and pilot gas or manually turn motor-knob clockwise ↻ to "O" OFF position.

CLEANING AND MAINTENANCE

- Keep area around log set clean and clear of debris.
- Periodically inspect air mixer and burner tube for foreign matter blocking air inlet and flame holes.
- Once every year, a qualified agency or certified chimney sweep should examine and clean venting system of fireplace.

INSPECTING BURNERS

Check pilot flame pattern and burner flame patterns often.

PILOT FLAME PATTERN

Figure 16 shows a correct pilot flame pattern. Figure 17 shows an incorrect pilot flame pattern. The incorrect pilot flame is not touching thermocouple. When thermocouple cools, heater will shut down.

If pilot flame pattern is incorrect, as shown in Figure 17

- turn heater off (see To Turn Off Gas to Appliance, page 11 or 12)
- see Troubleshooting, page 14

Note: Pilot flame on natural gas units will have a slight curve, but flame should be blue and have no yellow or orange color.

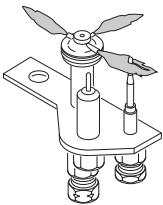

Figure 16 - Correct Pilot Flame

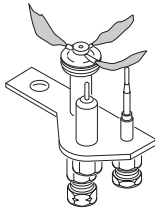

Figure 17 - Incorrect Pilot Flame

BURNER FLAME PATTERN

Figure 18 shows correct burner flame pattern.

NOTICE: Do not mistake orange flames with yellow tipping. Dirt or other fine particles are burned by heater, causing brief patches of orange flame.

If burner flame pattern is incorrect, as shown in Figure 19,

- turn appliance off (see To Turn Off Gas to Appliance, page 11 or 12)
- see Troubleshooting, page 14



Figure 18 - Correct Burner Flame Pattern

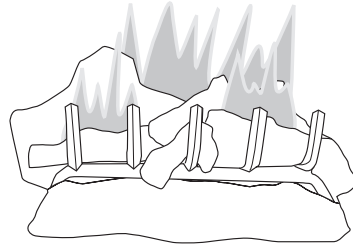





Figure 19 - Incorrect Burner Flame Pattern

TROUBLESHOOTING

⚠ WARNING: Turn off heater and let cool before servicing. Only a qualified service person should service and repair heater.

⚠ CAUTION: Never use a wire, needle or similar object to clean ODS/pilot. This can damage ODS/pilot unit.

Note: All troubleshooting items are listed in order of operation.

OBSERVED PROBLEM	POSSIBLE CAUSE	REMEDY
When  and  are pressed at the same time, there is no spark at ODS/pilot	<ol style="list-style-type: none"> 1. Switch in OFF position (module gives long steady beep) 2. Weak batteries 3. Ignitor electrode not connected to ignitor cable 4. Ignitor cable pinched or wet 5. Broken ignitor cable 6. Bad piezo ignitor 7. Ignitor electrode positioned wrong or broken 8. Bad module 	<ol style="list-style-type: none"> 1. Push switch on valve to "-" position 2. Replace batteries 3. Reconnect ignitor cable 4. Free ignitor cable if pinched by any metal or tubing. Keep ignitor cable dry 5. Replace ignitor cable 6. Replace piezo ignitor 7. Replace pilot assembly 8. Replace module
When  and  are pressed, there is spark at ODS/pilot but no ignition	<ol style="list-style-type: none"> 1. Gas supply turned off or equipment shutoff valve closed 2. Control knob not in ON position 3. Air in gas lines when installed 4. Weak batteries 5. Depleted gas supply (propane/LP only) 6. ODS/pilot is clogged 7. Gas regulator setting is not correct 8. Bad module 	<ol style="list-style-type: none"> 1. Turn on gas supply or open equipment shutoff valve 2. Turn control knob to ON position 3. Continue holding down control knob. Repeat igniting operation until air is removed 4. Replace batteries 5. Contact local propane/LP gas company 6. Clean ODS/pilot (see <i>Cleaning and Maintenance</i>, page 12) or replace ODS/pilot assembly 7. Replace gas regulator 8. Replace module
Burner does not light after pilot is lit	<ol style="list-style-type: none"> 1. Inlet gas pressure is too low 2. Wire disconnected from gas control 3. Bad module 4. Burner orifice(s) clogged 	<ol style="list-style-type: none"> 1. Contact local natural or propane/LP gas company 2. Reconnect leads (see <i>Wiring Diagram</i>, page 18) 3. Replace module 4. Clean burner (see <i>Cleaning and Maintenance</i>, page 12) or replace burner orifice(s)

TROUBLESHOOTING

Continued

OBSERVED PROBLEM	POSSIBLE CAUSE	REMEDY
Delayed ignition burner	<ol style="list-style-type: none">1. Manifold pressure is too low2. Burner orifice(s) clogged	<ol style="list-style-type: none">1. Contact local natural or propane/LP gas company2. Clean burner (see <i>Cleaning and Maintenance</i>, page 12) or replace burner orifice
Burner backfiring during combustion	<ol style="list-style-type: none">1. Burner orifice is clogged or damaged2. Damaged burner3. Gas regulator defective	<ol style="list-style-type: none">1. Clean burner (see <i>Cleaning and Maintenance</i>, page 12) or replace burner orifice2. Replace damaged burner3. Replace gas regulator
Orange flame in burner during burner combustion	<ol style="list-style-type: none">1. Not enough air2. Gas regulator defective	<ol style="list-style-type: none">1. Check burner for dirt and debris. If found, clean burner (see <i>Cleaning and Maintenance</i>, page 12)2. Replace gas control
Slight smoke or odor during initial operation (first hour)	<ol style="list-style-type: none">1. Residues from manufacturing processes and logs curing	<ol style="list-style-type: none">1. Problem will stop after a few hours of operation
Appliance produces a whistling noise when burner is lit	<ol style="list-style-type: none">1. Air in gas line2. Dirty or partially clogged burner orifice(s)	<ol style="list-style-type: none">1. Operate burner until air is removed from line. Have gas line checked by local natural or propane/LP gas company2. Clean burner (see <i>Cleaning and Maintenance</i>, page 12) or replace burner orifice
White powder residue forming within burner box or on adjacent walls or furniture	<ol style="list-style-type: none">1. When heated, vapors from furniture polish, wax, carpet cleaners, etc. may turn into white powder residue	<ol style="list-style-type: none">1. Turn appliance off when using furniture polish, wax, carpet cleaners or similar products
Remote does not function	<ol style="list-style-type: none">1. Battery is not installed. Battery power is low2. Bad module	<ol style="list-style-type: none">1. Replace batteries in remote control2. Replace module
Appliance produces a clicking/ticking noise just after burner is lit or shut off	<ol style="list-style-type: none">1. Metal expanding while heating or contracting while cooling	<ol style="list-style-type: none">1. This is normal with most appliances. If noise is excessive, contact qualified service person
Batteries drain quickly and must be replaced often	<ol style="list-style-type: none">1. Operating unit with glass doors closed2. Bad receiver module	<ol style="list-style-type: none">1. Operate unit with screens closed and glass doors fully open2. Replace receiver module

TROUBLESHOOTING *Continued*



WARNING: If you smell gas

- Shut off gas supply.
- Do not try to light any appliance.
- Do not touch any electrical switch; do not use any phone in your building.
- Immediately call your gas supplier from a neighbor's phone. Follow the gas supplier's instructions.
- If you cannot reach your gas supplier, call the fire department.

IMPORTANT: Operating heater where impurities in air exist may create odors. Cleaning supplies, paint, paint remover, cigarette smoke, cements and glues, new carpet or textiles, etc., create fumes. These fumes may mix with combustion air and create odors. These odors will disappear over time.

OBSERVED PROBLEM	POSSIBLE CAUSE	REMEDY
Appliance produces unwanted odors	<ol style="list-style-type: none"> 1. Appliance burning vapors from paint, hair spray, glues, cleaners, chemicals, new carpet, etc. (See <i>IMPORTANT</i> statement above) 2. Low fuel supply (propane/LP only) 3. Gas leak. See Warning statement at top of page 	<ol style="list-style-type: none"> 1. Open window to ventilate room. Stop using odor causing products while appliance is running 2. Refill supply tank (propane/LP only) 3. Locate and correct all leaks (see <i>Checking Gas Connections</i>, page 8)
Appliance shuts off in use (ODS operates)	<ol style="list-style-type: none"> 1. Not enough fresh air is available 2. Low line pressure 3. ODS/pilot is partially clogged 	<ol style="list-style-type: none"> 1. Open window and/or door for ventilation 2. Contact local natural or propane/LP gas company 3. Clean ODS/pilot (see <i>Cleaning and Maintenance</i>, page 12)
Gas odor even when control knob is in OFF position	<ol style="list-style-type: none"> 1. Gas leak. See Warning statement at top of page 2. Control valve defective 	<ol style="list-style-type: none"> 1. Locate and correct all leaks (see <i>Checking Gas Connections</i>, page 8) 2. Replace control valve
Gas odor during combustion	<ol style="list-style-type: none"> 1. Foreign matter between control valve and burner 2. Gas leak. See Warning statement at top of page 	<ol style="list-style-type: none"> 1. Take apart gas tubing and remove foreign matter 2. Locate and correct all leaks (see <i>Checking Gas Connections</i>, page 8)

IDENTIFYING ERROR SIGNALS FROM RECEIVER

Long signals (0.8 second tone, 0.2 second break) during ignition	1. Battery nearly down. (When signal appears the first time approximately 10 ignitions left)	1. Replace battery
5 second continuous tone	1. Cable is not connected, ON/OFF switch is in OFF position	1. Connect cables
5 short signals (8.2 second tone, 0.2 second break)	1. Ignition not successful, possible air in supply line	1. Switch to ON. Repeat procedure

SPECIFICATIONS

VTD-18N-TKA

- Rating: 35,000/50,000 Btu/Hr
 - Type Gas: Natural Gas
 - Ignition: Piezo
 - Manifold Pressure: 3.5" W.C.
 - Inlet Gas Pressure (in. of water):
Maximum - 10.5" W.C., Minimum - 5.0" W.C.*
 - Shipping Weight: 48 lbs.
- * For purpose of input adjustment.

VTD-24N-TKA

- Rating: 45,000/68,000 Btu/Hr
 - Type Gas: Natural Gas
 - Ignition: Piezo
 - Manifold Pressure: 3.5" W.C.
 - Inlet Gas Pressure (in. of water):
Maximum - 10.5" W.C., Minimum - 5.0" W.C.*
 - Shipping Weight: 57 lbs.
- * For purpose of input adjustment.

VTD-18P-TKA

- Rating: 35,000/50,000 Btu/Hr
 - Type Gas: Propane/LP
 - Ignition: Piezo
 - Manifold Pressure: 10" W.C.
 - Inlet Gas Pressure (in. of water):
Maximum - 14" W.C., Minimum - 11" W.C.*
 - Shipping Weight: 48 lbs.
- * For purpose of input adjustment.

VTD-24P-TKA

- Rating: 41,000/58,000 Btu/Hr
 - Type Gas: Propane/LP
 - Ignition: Piezo
 - Manifold Pressure: 10" W.C.
 - Minimum Inlet Gas Pressure (in. of water):
Maximum - 14" W.C., Minimum - 11" W.C.*
 - Shipping Weight: 57 lbs.
- * For purpose of input adjustment.

SERVICE HINTS

When Gas Pressure is Too Low

- pilot will not stay lit
- burners will have delayed ignition
- heater will not produce specified heat
- propane/LP gas supply may be low

You may feel your gas pressure is too low. If so, contact your local natural gas supplier.

TECHNICAL SERVICE

You may have further questions about installation, operation, or troubleshooting. If so, contact DESA Heating, LLC at 1-866-672-6040. When calling please have your model and serial numbers of your heater ready.

You can also visit DESA Heating, LLC's web site at www.desatech.com.

WIRING DIAGRAM

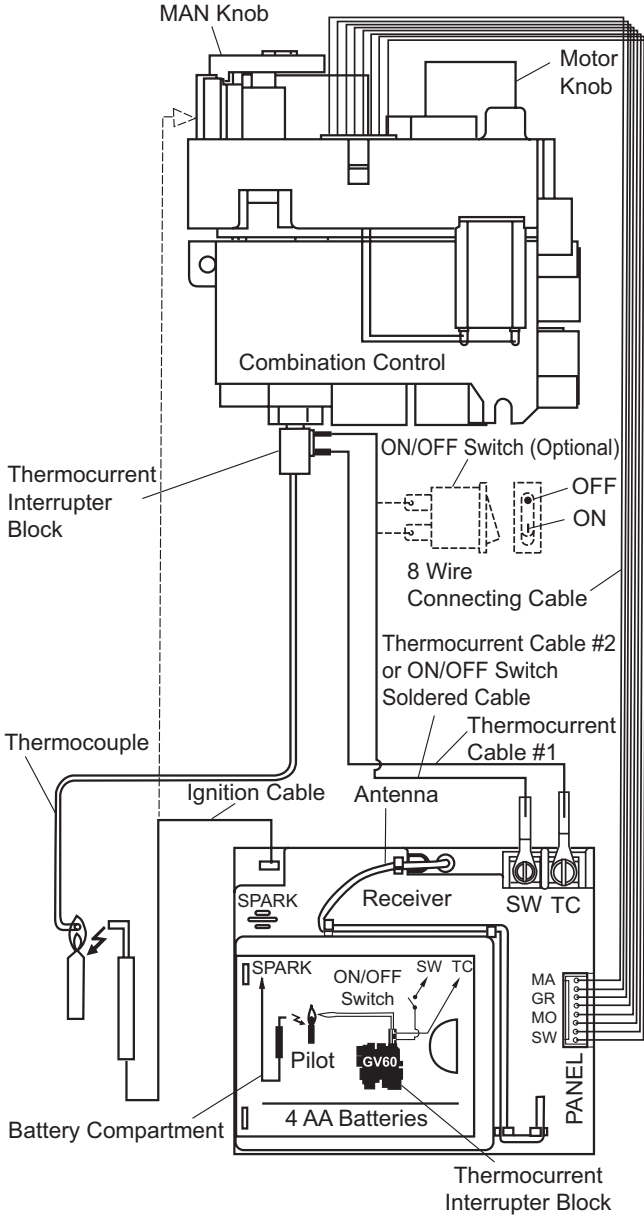

REPLACEMENT PARTS

Note: Use only original replacement parts. This will protect your warranty coverage for parts replaced under warranty.

PARTS UNDER WARRANTY

Contact authorized dealers of this product. If they can't supply original replacement part(s), call DESA Heating, LLC at 1-866-672-6040.

When calling DESA Heating, LLC, have ready:

- your name
- your address
- model and serial numbers of your heater
- how heater was malfunctioning
- purchase date

Usually, we will ask you to return the part to the factory.

PARTS NOT UNDER WARRANTY

Contact authorized dealers of this product. If they can't supply original replacement part(s), call DESA Heating, LLC at 1-866-672-6040 for referral information. A list of authorized dealers can be found by visiting www.desatech.com.

When calling DESA Heating, LLC, have ready:

- model and serial numbers of your heater
- the replacement part number

ACCESSORIES

Purchase these accessories from your local dealer. If they can not supply these accessories call DESA Heating, LLC at 1-866-672-6040 for information. You can also write to the address listed on the back page of this manual.

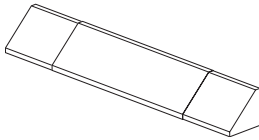

FIREPLACE HOOD

Black - GA6050

Brass - GA6052

Antique Brass - GA6053

For all models. Helps deflect heat away from mantel or wall above fireplace. Fits openings 28" to 48" wide.

DAMPER CLAMP - GA6080

For Remote-Ready and Variable Manually-Controlled Models. Permanently opens chimney flue damper for vented operation.

LAVA ROCK - GA6060

For all models. Order when additional rock is desired. (1.8 lb. bag)

EMBER FLAKE KIT - 112799-01

For all models.

CLEANING KIT - CCK

For all models. Your vent-free gas appliance requires regular cleaning and maintenance to prevent performance problems. This kit gives you the tools and instructions to make it easy to clean all critical areas of your appliance.

PARTS

MODELS VTD-18N-TKA, VTD-18P-TKA, VTD-24N-TKA AND VTD-24P-TKA

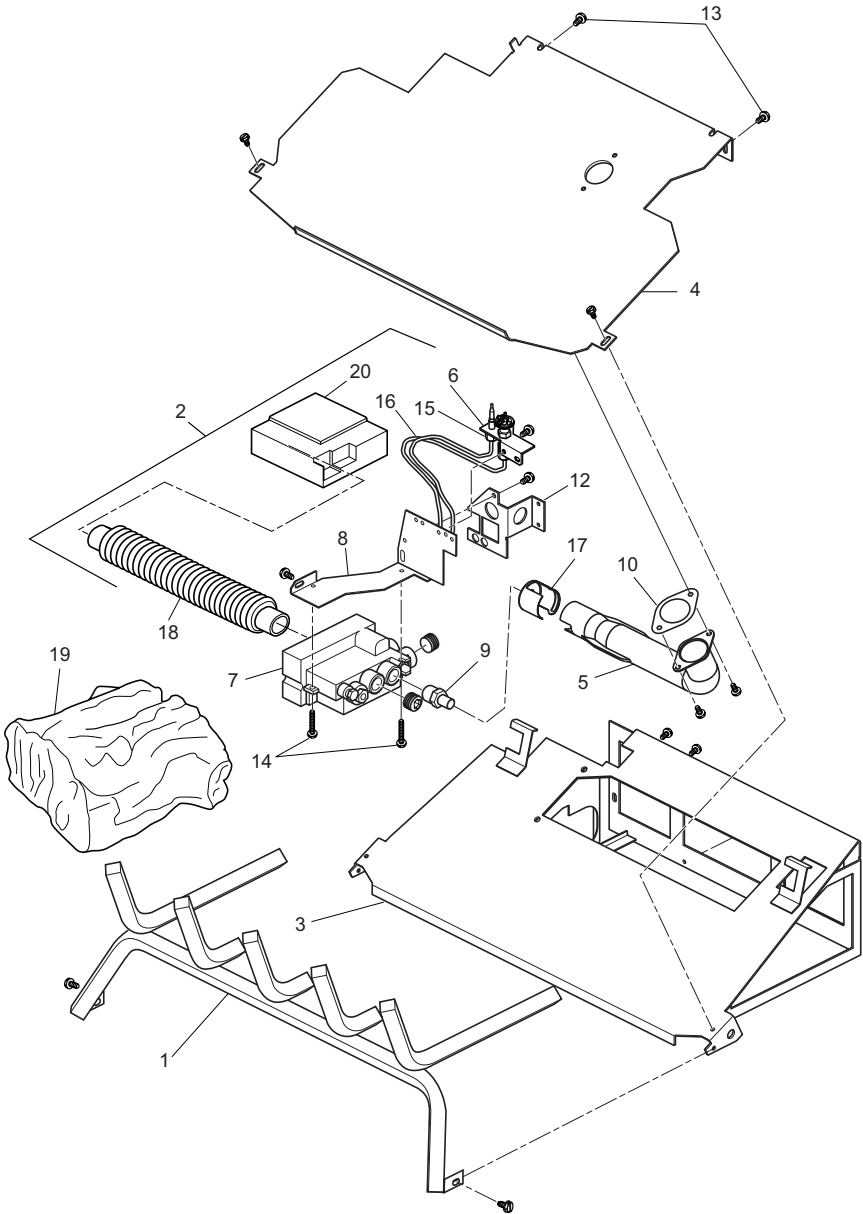

Note: Air shutter setting is 1/8" open for natural gas and full open for propane/LP gas.

PARTS

This list contains replaceable parts used in your heater. When ordering parts, follow instructions listed under Replacement Parts on page 19 of this manual.

KEY		PART NUMBER				DESCRIPTION	QTY.
NO.	VTD-18N-TKA	VTD-18P-TKA	VTD-24N-TKA	VTD-24P-TKA			
1	**	**	**	**	Grate Assembly	1	
2	112814-03	112814-04	112814-01	112814-02	Gas Train Assembly	1	
3	112821-01	112821-01	112810-01	112810-01	Chassis Weldments	1	
4	**	**	**	**	Log Plate Assembly (Logs not shown)	1	
5	117368-07	117368-08	117368-09	117368-09	Venturi	1	
6	116856-01	116856-02	116856-01	116856-02	Pilot	1	
7	112813-01	112813-02	112813-01	112813-02	Valve Assembly	1	
8	121515-01	121515-01	121515-01	121515-01	Pilot Bracket	1	
9	23105	23099	112371-05	112371-06	Orifice	1	
10	112370-01	112370-01	112370-01	112370-01	Gasket	1	
11	111800-01	111800-01	111800-01	111800-01	Screw #10 x 3/8"	11	
12	114378-01	114378-01	114378-01	114378-01	Bracket Stiffener	1	
13	11187	11187	11187	11187	Screw #8 x 1/4"	1	
14	112817-01	112817-01	112817-01	112817-01	Screw #10 x 1 1/4	2	
15	111828-01	111828-01	111828-01	111828-01	Compression Nut/ Sleeve 3/16"	1	
16	111817-03	111817-03	111817-03	111817-03	Flextube 3/16 x 12	1	
17	111821-02	111821-03	111821-01	111821-02	Air Shutter	1	
18	121516-01	121516-01	121516-01	121516-01	Black Hose	1	
19	121545-01	121545-01	121545-01	121545-01	Receiver Cover Log	1	
20	116673-01	116673-01	116673-01	116673-01	Module	1	
PARTS AVAILABLE — NOT SHOWN							
	100563-01	100563-01	100563-01	100563-01	Warning Plate	1	
	112796-01	112796-01	112796-01	112796-01	Lighting Instructions Plate	1	
	100639-01	100639-01	100639-01	100639-01	Caution Decal	1	
	111288-02	111288-02	111288-02	111288-02	Gas Line Flex 18"	1	
	112363-01	112363-01	112363-01	112363-01	Log Scrap Kit #1	1	
	112364-01	112364-01	112364-01	112364-01	Log Scrap Kit #2	1	
	114380-01	114380-01	114380-01	114380-01	Remote Transmitter	1	
	111801-17	111801-17	111801-17	111801-18	Rating Plate	1	
	26839	26839	26839	26839	Rockwool	1	

WARRANTY

KEEP THIS WARRANTY

Model (located on product or identification tag) _____

Serial No. (located on product or identification tag) _____

Date Purchased _____

Keep receipt for warranty verification.

DESA HEATING, LLC LIMITED WARRANTIES

New Products

Standard Warranty: DESA Heating, LLC warrants this new product and any parts thereof to be free from defects in material and workmanship for a period of four (4) years from the date of first purchase from an authorized dealer provided the product has been installed, maintained and operated in accordance with DESA Heating, LLC's warnings and instructions. When installed in a listed outdoor solid fuel burning fire-place, the warranty is limited to one (1) year for the burner system and logs.

For products purchased for commercial, industrial or rental usage, this warranty is limited to 90 days from the date of first purchase.

Factory Reconditioned Products

Limited Warranty: DESA Heating, LLC warrants factory reconditioned products and any parts thereof to be free from defects in material and workmanship for 30 days from the date of first purchase from an authorized dealer provided the product has been installed, maintained and operated in accordance with DESA Heating, LLC's warnings and instructions.

Terms Common to All Warranties

The following terms apply to all of the above warranties:

Always specify model number and serial number when contacting the manufacturer. To make a claim under this warranty the bill of sale or other proof of purchase must be presented.

This warranty is extended only to the original retail purchaser when purchased from an authorized dealer, and only when installed by a qualified installer in accordance with all local codes and instructions furnished with this product.

This warranty covers the cost of part(s) required to restore this product to proper operating condition and an allowance for labor when provided by a DESA Heating, LLC Authorized Service Center or a provider approved by DESA Heating, LLC. Warranty parts must be obtained through authorized dealers of this product and/or DESA Heating, LLC who will provide original factory replacement parts. Failure to use original factory replacement parts voids this warranty.

Travel, handling, transportation, diagnostic, material, labor and incidental costs associated with warranty repairs, unless expressly covered by this warranty, are not reimbursable under this warranty and are the responsibility of the owner.

Excluded from this warranty are products or parts that fail or become damaged due to misuse, accidents, improper installation, lack of proper maintenance, tampering, or alteration(s).

This is DESA Heating, LLC's exclusive warranty, and to the full extent allowed by law; this express warranty excludes any and all other warranties, express or implied, written or verbal and limits the duration of any and all implied warranties, including warranties of merchantability and fitness for a particular purpose to four (4) years on new products and 30 days on factory reconditioned products from the date of first purchase. DESA Heating, LLC makes no other warranties regarding this product.

DESA Heating, LLC's liability is limited to the purchase price of the product, and DESA Heating, LLC shall not be liable for any other damages whatsoever under any circumstances including indirect, incidental, or consequential damages.

Some states do not allow limitations on how long an implied warranty lasts or the exclusion or limitation of incidental or consequential damages, so the above limitation or exclusion may not apply to you.

This warranty gives you specific legal rights, and you may also have other rights which vary from state to state.

For information about this warranty contact:



111826 03

NOT A UPC



DESA Heating, LLC
2701 Industrial Drive
Bowling Green, KY 42101
www.desatech.com
1-866-672-6040

111826-03
Rev. H
06/08